



## **AGENDA- CITY COUNCIL MEETING**

January 24, 2023

6:30 PM

Page

**1. CALL TO ORDER.**

**2. PLEDGE OF ALLEGIANCE.**

Invocation will be given by Fifth Ward Councilmember Karen Bunnell.

**3. ROLL CALL.**

**4. ADOPTION OF AGENDA.**

**5. PRESENTATIONS/PROCLAMATIONS.**

5.1. Hotel Hayes update from the Jeffers Group

**6. PUBLIC HEARINGS.**

6.1. Conduct a Public Hearing to Receive Citizen Comment on the City's Housing and Community Development Needs

6 - 7

[6A- Public Hearing - Housing and Community Development](#)

[Needs.pdf](#) 

**7. CITIZEN COMMENTS.**

(3-Minute Limit)

**8. PETITIONS & COMMUNICATION FROM CITY STAFF AND OTHER GOVERNMENTAL ENTITIES.**

(Accept and Place on File)

8.1. Accept and Place on File, the CDBG, HOME and CDBG-CV Homeless Prevention financial summaries through December 31, 2022.



8 - 13






## 9. CONSENT CALENDAR

### Consent Action





- 9.1 **Minutes of the Regular Meeting of January 10, 2023** 14 - 23  
[CCMIN 1.10.23.pdf](#)   
*Approve the minutes of the regular City Council Meeting of January 10, 2023*
- 9.2 **Release of Jackson Police Department K9 to Det. Michael Galbreath** 24 - 26  
[K9 Release to Det. Galbreath Dept. Cover Memo Report and Resolution FINAL.pdf](#)   
*Approve resolution authorizing the release of Jackson Police Department K9 'Gleeson' to Det. Michael Galbreath.*
- 9.3 **Local Governing Body Resolution for Charitable Gaming License** 27 - 34  
[LEAN ROCKET LAB.pdf](#)   
*Approve resolution supporting the request from Lean Rocket Lab to be recognized as a nonprofit organization for the purpose of obtaining a charitable gaming license.*
- 9.4 Accept with regret, the resignation of Kenneth Robinson from the Affordable Housing Development Board **Resignation - KRobinson - Affordable Housing.pdf** 35
- 9.5 Appointment to the Affordable Housing Development Board **Appointment - TBerry - Affordable Housing.pdf** 36 - 39  
*Approve the Mayor's recommendation to appoint Toby Berry to the Affordable Housing Development Board for a five-year term, beginning immediately and ending on December 31, 2027.*
- 9.6 Appointment to the Environmental Commission **Appointment - CWood - Environmental Commission.pdf** 40 - 43  
*Approve the Mayor's recommendation to appoint Conner Wood as the City Planning Commission's representative on the Environmental Commission for a concurrent term, beginning immediately and ending on December 31, 2025.*

- 9.7 Appointment to the Historic District Commission 44 - 47  
[Appointment - JStressman - Historic District Commission.pdf](#)  
  
*Approve the Mayor's recommendation to appoint Jacob Stressman to the Historic District Commission for a term of three-years beginning immediately and ending on December 31, 2025.*
- 9.8 Appointment to the Local Development Finance Authority 48  
[LDFA Appointment - Ehnis.pdf](#)   
*Approve the Mayor's recommendation to appoint Finance Director Heather Ehnis to the Local Development Finance Authority/Brownfield Redevelopment Authority for a four-year term, beginning immediately and ending on June 3, 2026.*

## 10. OTHER BUSINESS.

- 10.1. Evaluate City Homeless Efforts (Discussion)
- 10.2. Second Reading/Final Adoption Ordinance No. 2023-01 49 - 51  
[10B- 2023-01 agenda packet.pdf](#)   
*Approve the second reading/final adoption of an ordinance amending Chapter 18 - Offenses, Article VI - Offenses Against Public Morals, Division 2, Marihuana and Drug Paraphernalia to Correct Section 18-156.*
- 10.3. Second Reading/Final Adoption Ordinance No. 2023-02 52 - 60  
[10C - 2023-02 agenda packet.pdf](#)   
*Approve the second reading/final adoption of an ordinance amending Chapter 2, Article IV of the City of Jackson Code of Ordinances to revise the record disposal schedule for tax rolls and special assessment ledgers.*
- 10.4. Second Reading/Final Adoption Ordinance No. 2023-03 61 - 86  
[10D - 2023-03 agenda packet.pdf](#)   
*Approve the second reading/final adoption of an ordinance amending Chapter 28 - Zoning of the City of Jackson Code of Ordinances.*

## 11. NEW BUSINESS.

- 11.1. Approval of First Extension of the 2022 As Needed Materials Testing Services Contract 87 - 89  
[Engineering 2022 Matls Testing Contract 1st Ext.pdf](#)   
*Approval of the first extension of the 2022 As Needed Materials Testing Services Contract with Professional Services Industries (PSI), Inc. of Lansing, Michigan in the estimated amount of \$125,000.00, and authorization for the Mayor and City Clerk to execute the appropriate document(s) in accordance with the Purchasing Agent.*
- 11.2. Overhead Doors Project at Jackson Fire Department Station #1 90 - 119  
[01-24-23 - JFD Overhead Door Memos.pdf](#)   
*Accept bid by Overhead Door Company for Fire Department Station #1.*
- 11.3. Windows Update Project at Jackson Fire Department Station #1 120 - 161  
[01-24-23 - JFD Windows MemosFD](#)  
[Windows\\_20230113073916.pdf](#)   
*Accept bid by R.W. Mercer for window replacement at Fire Department Station #1.*
- 11.4. Approval of Doug Jones and Chris Turner Community of Shapes Art Sculpture for the MLK Boulevard Roundabout and for the City Attorney and the Parks and Recreation Director to move forward with the artists agreement including delivery and installation. Not to exceed \$30,000.00 162 - 345  
[MLK Art Project Agenda.pdf](#)   
*Approval of Doug Jones and Chris Turner Community of Shapes Art Sculpture for the MLK Boulevard Roundabout and for the City Attorney and the Parks and Recreation Director to move forward with the artists agreement including delivery and installation. Not to exceed \$30,000.00.*

**12. CITY COUNCILMEMBER'S COMMENTS.**

**13. MANAGER'S COMMENTS.**

**14. ADJOURNMENT.**

**MEMO TO:** Mayor and City Councilmembers  
**FROM:** Jonathan Greene, City Manager  
**DATE:** January 24, 2023  
**SUBJECT:** Conduct a Public Hearing to Receive Citizen Comment on the City's Housing and Community Development Needs

---

**Recommendation:**

Conduct a Public Hearing to receive citizen comment on the City's housing and community development needs.

Attached is a memorandum from Shane LaPorte, Director of the Community Development Department, requesting that City Council conduct a Public Hearing to receive citizen comment on the City's housing and community development needs as part of the development of the 2023 – 2024 Annual Action Plan for CDBG/HOME funds. No action is required at the close of the Public Hearing.

I recommend approval of the request. Your consideration and concurrence is appreciated.

JG

## DEPARTMENTAL REPORT

**MEMO TO:** Jonathan Greene, City Manager

**FROM:** Shane LaPorte, Director of Community Development

**DATE:** January 24, 2023

**RECOMMENDATION:** Conduct a Public Hearing to Receive Citizen Comment on the City's Housing and Community Development Needs

---

### SUMMARY

Conduct a Public Hearing to receive citizen comment on the City's housing and community development needs to assist in the development of the City's Annual Action Plan for Community Development Block Grant (CDBG) and HOME Investment Partnerships Program (HOME) funds.

### BUDGETARY CONSIDERATIONS

There are no budgetary considerations associated with the Public Hearing.

### HISTORY, BACKGROUND and DISCUSSION

HUD regulation at 24 CFR 91.105(e) and the City's Citizen Participation Plan require a hearing allowing the public to identify housing and non-housing community development needs be held during the development of the annual action plan. Council will consider all comments received, either oral or written, with a summary of those comments incorporated in the action plan.

### DISCUSSION OF THE ISSUE

Notice of the Public Hearing was published in the *Jackson Citizen Patriot / Mlive* on Saturday, January 14, 2023. Development of the 2023 – 2024 Annual Action Plan is underway with the draft plan being available for a 30-day public comment period on or about March 21, 2023.

### POSITIONS

Requested action is for City Council to conduct a Public Hearing to receive citizen comment on the City's housing and community development needs. No other action is required at this time.

---

**MEMO TO:** Mayor and City Councilmembers  
**FROM:** Jonathan Greene, City Manager  
**DATE:** January 24, 2023  
**SUBJECT:** Accept and place on file the CDBG, HOME, and CDBG-CV Homeless Prevention Financial Summaries through December 31, 2022

---

**Recommendation:**

Accept and place on file the CDBG, HOME and CDBG-CV Homeless Prevention Financial Summaries through December 31, 2022.

Attached is a memo from Shane LaPorte, the Director of Community Development, regarding accepting and placing on file the CDBG, HOME, and CDBG-CV Homeless Prevention Financial Summaries through December 31, 2022. Monthly expenses includes Personnel Salaries & Expenses, Administration Cost, Demolition Expenses, Boos Center Improvement Cost, and Homeless Prevention Administration Expense.

I recommend accepting and placing on file the CDBG, HOME, and CDBG-CV Homeless Prevention Financial Summaries through December 31, 2022. Your consideration and concurrence is appreciated.

JG

## DEPARTMENTAL REPORT

**MEMO TO:** Jonathan Greene, City Manager

**FROM:** Shane LaPorte, Director of Community Development

**DATE:** January 24, 2022

**RECOMMENDATION:** To accept and place on file the CDBG, HOME, and CDBG-CV Homeless Prevention Financial Summaries through December 31, 2022

---

### SUMMARY

Attached please find the Financial Summaries for the CDBG, HOME, and CDBG-CV Homeless Prevention funds for the month ending December 31, 2022.

Monthly expenses included:

- Personnel – Salaries & Expenses
- Administration – Rehabilitation Administration Cost
- Demolition Expense
  - ❖ 1113-1115 Greenwood
    - Pre-Demo Cost (Red Cedar)
      - ❖ 416 Randolph
      - ❖ 158 Randolph
      - ❖ 355 Cooper
- Boos Center Improvements
  - ❖ Boos Center Playground Expenses
- CDBG-CV Homeless Prevention
  - ❖ City Admin Expense

My recommendation is to accept and place on file the CDBG, HOME, and CDBG-CV Homeless Prevention Financial Summaries through December 31, 2022.

---

ATTACHMENTS

**City of Jackson**  
**Community Development Block Grant**  
**Monthly Financial Summary**  
**For the Six Months Ended December 31, 2022**

	<u>Budgeted</u>	<u>Expended Prior Year</u>	<u>Actual Month-to-Date</u>	<u>Actual Year-to-Date</u>	<u>Total Funds Expended- to-Date</u>	<u>Balance</u>	<u>Percent Spent</u>
<b><u>Administration</u></b>							
1 Administration & Planning							
FY 2021/2022	145,000	109,937	-	35,063	145,000	-	100.0%
FY 2022 / 2023	120,000	-	14,983	3,161	3,161	116,839	2.6%
<b><u>Code Enforcement</u></b>							
2 City Attorney Office							
FY 2021/2022	20,000	20,000	-	-	20,000	-	100.0%
FY 2022 / 2023	25,000	-	-	5,829	5,829	19,171	23.3%
<b><u>Rehabilitation Projects</u></b>							
3 Rehabilitation Administration							
FY 2021/2022	135,000	108,932	-	26,068	135,000	-	100.0%
FY 2022 / 2023	120,000	-	10,610	75,567	75,567	44,433	63.0%
4 City Emergency Hazard Repair Program							
FY 2020/2021	497,059	479,248	-	17,476	496,724	335	99.9%
FY 2022 / 2023	250,000	-	-	-	-	250,000	0.0%
<b><u>Street Projects</u></b>							
5 Special Assessments							
FY 2019/2020	25,000	4,365	-	1,715	6,080	18,920	24.3%
6 Cooley: Morrell to Biddle							
FY 2021/2022	175,176	170,936	-	-	170,936	4,240	97.6%
7 Biddle: Mechanic to MLK Jr Dr							
FY 2021/2022	134,702	130,463	-	-	130,463	4,239	96.9%
8 Perrine-Burr							
FY 2021/2022	56,500	42,692	-	2,596	45,289	11,211	80.2%
FY 2022/2023	463,000	-	-	-	-	463,000	<b>0.0%</b>

**City of Jackson**  
**Community Development Block Grant**  
**Monthly Financial Summary**  
**For the Six Months Ended December 31, 2022**

	<u>Budgeted</u>	<u>Expended Prior Year</u>	<u>Actual Month-to-Date</u>	<u>Actual Year-to-Date</u>	<u>Total Funds Expended- to-Date</u>	<u>Balance</u>	<u>Percent Spent</u>
<b><u>Recreation -Other Projects</u></b>							
9 Loomis Park Court Improvements	312,849	304,867	-	-	304,867	7,982	97.4%
10 Boo Center Improvements							
FY 2020/2021	305,000	245,982	-	-	245,982	59,018	80.6%
FY 2021/2022	1,005,980	75,180	532,315	532,315	607,495	398,485	<b>60.4%</b>
FY 2022/2023	241,133	-	-	-	-	241,133	<b>0.0%</b>
<b><u>Demolition</u></b>							
11 Demolition							
FY 2020/2021	300,000	241,639	17,065	45,805	287,444	12,556	95.8%
FY 2021/2022	75,000	-	-	-	-	75,000	0.0%
FY 2022 / 2023	150,000	-	-	-	-	150,000	0.0%

**City of Jackson**  
**HOME**  
**Monthly Financial Summary**  
**For the Six Months Ended December 31, 2022**

	<u>Budgeted</u>	<u>Expended Prior Year</u>	<u>Actual Month-to-Date</u>	<u>Actual Year-to-Date</u>	<u>Total Funds Expended- to-Date</u>	<u>Balance</u>	<u>Percent Spent</u>
1 Rehabilitation Assistance Program							
FY 2019/2020	55,068	54,384	-	-	54,384	684	98.8%
2 HOME Administration			-				
FY 2019/2020	25,000	25,000	-	-	25,000	-	100.0%
FY 2020/2021	33,000	31,703	-	-	31,703	1,297	96.1%
FY 2021/2022	16,000	16,000	-	-	16,000	-	100.0%
FY 2022/2023	30,000	-	-	-	-	30,000	0.0%
3 CHDO Reservation							
FY 2019/2020	503,052	358,955	-	83,371	442,326	60,726	87.9%
FY 2020/2021	287,439	-	-	-	-	287,439	0.0%
FY 2021/2022	118,329	-	-	-	-	118,329	0.0%
FY 2022/2023	129,404	-	-	-	-	129,404	0.0%
4 CHDO Operating Expenses							
FY 2019/2020	18,000	3,958	-	11,518	15,476	2,524	86.0%
FY 2020/2021	16,800	-	-	-	-	16,800	0.0%
FY 2022/2023	17,226	-	-	-	-	17,226	0.0%
5 Partnership Park - Homeowner Rehabilitation (CAA)							
FY 2021/2022	200,000	-	-	-	-	200,000	0.0%
FY 2022/2023	200,000	-	-	-	-	200,000	0.0%

**City of Jackson**  
**2020/8 CV Homeless Prevention**  
**Monthly Financial Summary**  
**For the Six Months Ended December 31, 2022**

	<u>Budgeted</u>	<u>Expended Prior Year</u>	<u>Actual Month-to-Date</u>	<u>Actual Year-to-Date</u>	<u>Total Funds Expended- to-Date</u>	<u>Balance</u>	<u>Percent Spent</u>
<b><u>Administration</u></b>							
1 CDBG-CV Admin City FY 2020/2021	60,000	12,383	656	2,293	14,676	45,324	24.5%
2 CDBG-CV Admin CAA FY 2020/2021	33,270	33,270	-	-	33,270	-	100.0%
<b><u>Homeless Prevention - Public Services</u></b>							
3 Eviction Prevention FY 2020/2021	120,000	120,000	-	-	120,000	-	100.0%
4 Foreclosure Prevention FY 2020/2021	41,112	41,112	-	-	41,112	-	100.0%
5 Water Shut-off Protection FY 2020/2021	35,313	35,313	-	-	35,313	-	100.0%
<b><u>Parks &amp; Recreation</u></b>							
6 Boos Center - HVAC	319,425	97,207	-	75,055	172,262	147,163	53.9%
7 Boos Center - Trail	336,325	-	-	-	-	336,325	0.0%



**CITY COUNCIL MEETING MINUTES**  
January 10, 2023

**CALL TO ORDER:**

The Jackson City Council met in regular session in Council Chambers and was called to order at 6:30 p.m. by Mayor Daniel Mahoney.

**PLEDGE OF ALLEGIANCE AND INVOCATION:**

Council joined in the Pledge of Allegiance. Invocation was given by Fourth Ward Councilmember Laura Dwyer Schlecte.

**ROLL CALL:**

Present: Mayor Daniel Mahoney, Vice Mayor/First Ward Councilmember Arlene Robinson, Second Ward Councilmember Freddie Dancy, Third Ward Councilmember Angelita Gunn, Fourth Ward Councilmember Laura Dwyer Schlecte, Fifth Ward Councilmember Karen Bunnell, and Sixth Ward Councilmember Will Forgrave.

Absent: none.

Also present: City Manager Jonathan Greene, City Attorney Matthew Hagerty, City Clerk Andrea Muray, Director of Police and Fire Services Elmer Hitt, Chief Equity Officer John Willis, City Engineer Jon Dowling, Director of Public Works Mike Osborne, and Director of Community Services Shane LaPorte.

**ADOPTION OF AGENDA:**

Motion was made by Councilmember Schlecte, seconded by Councilmember Forgrave to adopt the agenda with the addition of 8D Homeless Update, and the removal of 9J - Special Event Application - Winter Fest. Vote - Yeas: Mayor Mahoney, Vice Mayor Robinson, Councilmembers Dancy, Gunn, Schlecte, Bunnell, and Forgrave (7). Nays: none. Motion carried.

**PRESENTATIONS/PROCLAMATIONS:**

- A. **City of Jackson’s Audit Report for Fiscal Year ended June 30, 2022** *Presentation by Rehmann, LLC, of the City of Jackson’s Audit Report for Fiscal Year ended June 30, 2022.*

Nate Baldermann from Rehmann gave an overview of the City of Jackson’s Audit Report for Fiscal Year ended June 30, 2022.

1. Receipt of the City of Jackson’s Audit Report for Fiscal Year ended June 30, 2022.

Motion was made by Councilmember Schlecte, seconded by Councilmember Forgrave to receive the City of Jackson’s Audit Report for Fiscal Year ended June 30, 2022. Vote – Yeas: Mayor Mahoney, Vice Mayor Robinson, Councilmembers Dancy, Gunn, Schlecte, Bunnell, and Forgrave (7). Nays: none. Motion carried.

**PUBLIC HEARINGS:** none.

**CITIZEN COMMENTS:**

Citizen comments were heard and the meeting continued.

**PETITIONS & COMMUNICATION FROM CITY STAFF AND OTHER GOVERNMENTAL ENTITIES:**

- A. **Minutes of the December 2022 Board of Review**

Motion was made by Councilmember Schlecte, seconded by Councilmember Gunn to accept and place on file the minutes of the December 2022 Board of Review. Vote – Yeas: Mayor Mahoney, Vice Mayor Robinson, Councilmembers Dancy, Gunn, Schlecte, Bunnell, and Forgrave (7). Nays: none. Motion carried.

- B. **City of Jackson, Michigan Financial Statements As of and For the Five Months Ended November 30, 2022**

Motion was made by Councilmember Schlecte, seconded by Vice Mayor Robinson to accept and place on file the City of Jackson Financial Statements as of and for the five months ended November 30, 2022. Vote – Yeas: Mayor Mahoney, Vice Mayor Robinson, Councilmembers Dancy, Gunn, Schlecte, Bunnell, and Forgrave (7). Nays: none. Motion carried.

**C. Accept and Place on file, the CDBG, HOME, and CDBG-CV Homeless Prevention Financial Summaries through November 30, 2022.**

Motion was made by Councilmember Schlecte, seconded by Councilmember Bunnell to accept and place on file the CDBG, HOME, and CDBG-CV Homeless Prevention Financial Summaries through November 30, 2022. Vote – Yeas: Mayor Mahoney, Vice Mayor Robinson, Councilmembers Dancy, Gunn, Schlecte, Bunnell, and Forgrave (7). Nays: none. Motion carried.

**D. Residents in Action Homeless Project Proposal for City of Jackson RFP – 12/22/22 – 1/10/2023**

Motion was made by Councilmember Schlecte, seconded by Councilmember Bunnell to accept and place on file the RIA update. Vote – Yeas: Mayor Mahoney, Vice Mayor Robinson, Councilmembers Dancy, Gunn, Schlecte, Bunnell, and Forgrave (7). Nays: none. Motion carried.

**CONSENT CALENDAR:**

**A. Minutes of the Regular Meeting of December 13, 2022**

*Approve the minutes of the regular City Council Meeting of December 13, 2022.*

**B. Minutes of the Special Meeting of December 20, 2022**

*Approve the minutes of the special City Council Meeting of December 20, 2022.*

**C. Accept with regret, the resignation of Danielle Dobies from the Ella Sharp Park and Parks & Recreation Boards**

**D. Reappointment to the Martin Luther King Corridor Improvement Authority**

*Approve the Mayor's recommendation to reappoint James Johnson, Jr. to the Martin Luther King Corridor Improvement Authority for a term of four years, beginning immediately and ending on December 31, 2026.*

**E. Corrective Resolution for Special Assessment Roll No. 3440**

*Approve a Corrective Resolution for Special Assessment Roll No. 3440 for Repaving of Greenwood Avenue from Morrell Street to Fourth Street, confirmed March 8, 2022*

**F. Traffic Control Order 2387**

**Biddle Street, Blackstone Street to Greenwood Avenue**

*Approval of Traffic Control Order 2387 to remove parking restrictions on Biddle Street from Blackstone Street to Greenwood Avenue, and rescind Traffic Control Order 491.*

**G. Engineer's Report for Pavement Replacement  
North Street – Wisner Street to West Avenue**

*Receive the Engineer's Report for pavement replacement on North Street from Wisner Street to West Avenue and establish February 7, 2023 at the City Council meeting as the time and place to hold a public hearing of necessity.*

**H. Special Event Application – Fairy Festival**

*Approve a request from the Jackson School of the Arts to host their Fairy Festival April 29, 2023 in Parking Lot #6, downtown Jackson.*

**I. Special Event Application – Groundhog Gallop**

*Approve a request from Grow Jackson to host the Groundhog Gallop on February 4, 2023 at Parkside Middle School and on the Martin Luther King, Jr. Equality Trail.*

Motion was made by Councilmember Schlecte, seconded by Councilmember Bunnell to approve the consent calendar. Vote – Yeas: Mayor Mahoney, Vice Mayor Robinson, Councilmembers Dancy, Gunn, Schlecte, Bunnell, and Forgrave (7). Nays: none. Motion carried.

**OTHER BUSINESS:**

**A. Update on the Homeless Situation**

Motion was made by Councilmember Schlecte, seconded by Councilmember Forgrave to add an update on the Homeless Situation added as Item A under Other Business. Vote – Yeas: Mayor Mahoney, Vice Mayor Robinson, Councilmembers Gunn, Schlecte, Bunnell, and Forgrave (6). Nays: Councilmember Dancy (1). Motion carried.

City Manager Jonathan Greene gave an update on the pallets, TA Wilson Academy, and the warming shelter.

**NEW BUSINESS:**

**A. Approve the JNET Interlocal Agreement**

**Recommendation:** *Approval of the JNET Interlocal Agreement and allowing the City Manager to execute it on behalf of the City of Jackson.*

Motion was made by Councilmember Schlecte, seconded by Councilmember Dancy to approve the JNET Interlocal Agreement. Vote – Yeas: Mayor Mahoney, Vice Mayor Robinson, Councilmembers Dancy, Gunn, Schlecte, Bunnell, and Forgrave (7). Nays: none. Motion carried.

**B. Approval of the contract award for the Sodium Hydroxide System Improvements at the City of Jackson, Water Treatment Plant to Monroe Plumbing and Heating Co. of Monroe, MI in the amount of \$395,000, to be funded by the City Local Recovery Funds under the American Rescue Plan Act**

**Recommendation:** *Approve the contract award for the Sodium Hydroxide System Improvements at the City of Jackson, Water Treatment Plant to Monroe Plumbing and Heating Co. of Monroe, MI in the amount of \$395,000, to be funded by the City Local Recovery Funds under the American Rescue Plan Act.*

Motion was made by Councilmember Schlecte, seconded by Councilmember Dancy to approve the contract award for the Sodium Hydroxide System Improvements at the City of Jackson Water Treatment Plant in the amount of \$395,000 to be funded by the City Local Recovery Funds under the American Rescue Plan Act. Vote – Yeas: Mayor Mahoney, Vice Mayor Robinson, Councilmembers Dancy, Gunn, Schlecte, Bunnell, and Forgrave (7). Nays: none. Motion carried.

**C. Amendment 2 to the Professional Engineering Services contract with Fishbeck**

**Recommendation:** *Approval of Amendment 2 to the contract for professional engineering services for improvements to the wastewater treatment plant with Fishbeck, Inc. of Grand Rapids, Michigan in the amount of \$36,404.00, and authorization for the City Manager and Director of Public works to sign the appropriate document.*

Motion was made by Councilmember Schlecte, seconded by Councilmember Dancy to approve Amendment 2 to the contract for professional services for improvement to the Wastewater Treatment Plant with Fishbeck in the amount of \$36,404.00. Vote – Yeas: Mayor Mahoney, Vice Mayor Robinson, Councilmembers Dancy, Gunn, Schlecte, Bunnell, and Forgrave (7). Nays: none. Motion carried.

**D. Changes to the Standard Lighting Contract for streetlights with Consumers Energy for removal of streetlights on Wisner Street and on Washington Avenue**

**Recommendation:** *Approve the resolution for Changes to the Standard Lighting Contract with Consumers Energy for removal of streetlights on Wisner Street and on Washington Avenue and authorize the Mayor and City Clerk to execute the appropriate documents.*

Motion was made by Councilmember Forgrave, seconded by Councilmember Gunn to approve the resolution for Changes to the Standard Lighting Contract with Consumers Energy for removal of streetlights on Wisner Street and on Washington Avenue. Vote – Yeas: Mayor Mahoney, Vice Mayor Robinson, Councilmembers Dancy, Gunn, Schlecte, Bunnell, and Forgrave (7). Nays: none. Motion carried.

**E. Change Order 2 to the Miscellaneous Construction contract with Bailey Excavating, Inc.**

**Recommendation:** *Approve Change Order 2 to the Miscellaneous Construction contract with Bailey Excavating, Inc. in the increased amount of \$89,248.97 for the repair of the storm sewer on Winthrop Avenue and authorize the City Manager and City Engineer to execute the appropriate document.*

Motion was made by Councilmember Schlecte, seconded by Councilmember Forgrave to approve Change Order 2 to the Miscellaneous Construction Contract with Bailey Excavating, Inc. in the increased amount of \$89,248.97. Vote – Yeas: Mayor Mahoney, Vice Mayor Robinson, Councilmembers Dancy, Gunn, Schlecte, Bunnell, and Forgrave (7). Nays: none. Motion carried.

**F. Request to adopt a resolution approving a selected project for additional funds for the 2023-2026 Transportation Improvement Plan**

**Recommendation:** *Adopt a resolution to approve a project as selected for inclusion in the 2023-2026 Transportation Improvement Plan (TIP) and to acknowledge that the City is willing to pay the local match for the selected projects.*

Motion was made by Councilmember Schlecte, seconded by Councilmember Bunnell to adopt a resolution approving a selected project for additional funds for the 2023-2026 Transportation Improvement Plan. Vote – Yeas: Mayor Mahoney, Vice Mayor Robinson, Councilmembers Dancy, Gunn, Schlecte, Bunnell, and Forgrave (7). Nays: none. Motion carried.

**G. Amendment 2 to the 2022 Major Street Engineering Contract**

**Recommendation:** *Approval of Amendment 2 to the 2022 Major Street Engineering contract with Spaulding DeDecker Associates, Inc. (SDA) of Novi, Michigan at a not-to-exceed cost of \$109,825.00 and authorization for the City Manager and City Engineer to execute the appropriate documents.*

Motion was made by Councilmember Schlecte, seconded by Councilmember Gunn to approve Amendment 2 to the 2022 Major Engineering contract at a not-to-exceed cost of \$109,825.00. Vote – Yeas: Mayor Mahoney, Vice Mayor Robinson, Councilmembers Dancy, Gunn, Schlecte, Bunnell, and Forgrave (7). Nays: none. Motion carried.

**H. Amendment 1 to the Engineering and Project Administration, SCADA Software Upgrades Contract for the City of Jackson Wastewater Treatment Plant**

**Recommendation:** *Approve Amendment 1 to the Engineering and Project Administration, SCADA Software Upgrades Contract with Tetra Tech of Ann Arbor, MI at a not-to-exceed cost of \$96,250 and authorize the City Manager and Director of Public Works to execute the appropriate documents.*

Motion was made by Vice Mayor Robinson, seconded by Councilmember Bunnell to approve Amendment 1 to the Engineering and Project Administration, SCADA Software Upgrades Contract for the City of Jackson Wastewater Treatment Plant at a not-to-exceed cost of \$96,250. Vote – Yeas: Mayor Mahoney, Vice Mayor Robinson, Councilmembers Dancy, Gunn, Schlecte, Bunnell, and Forgrave (7). Nays: none. Motion carried.

**I. Revocation of the Conditional Phase 1 Class C License and Development Agreement for Wildwood Essence LLC**

**Recommendation:** *Approve the revocation of the previously authorized Conditional Phase One Class C License and Development Agreement for Wildwood Essence LLC. Located at 1623 Wildwood Ave.*

Motion was made by Councilmember Schlecte, seconded by Councilmember Bunnell to approve the revocation of the Conditional Phase 1 Class C License and Development Agreement for Wildwood Essence, LLC. Vote – Yeas: Mayor Mahoney, Vice Mayor Robinson, Councilmembers Dancy, Gunn, Schlecte, Bunnell, and Forgrave (7). Nays: none. Motion carried.

**J. Approve an extension of the Development Agreement between the City of Jackson and Leon Cannabis LLC**

**Recommendation:** *Approve an extension of the Development Agreement between the City of Jackson and Leon Cannabis LLC, until January 19th 2024 and authorize the City Manager and City Attorney to make minor modifications as necessary.*

Motion was made by Councilmember Schlecte, seconded by Councilmember Forgrave to approve an extension of the Development Agreement between the City of Jackson and Leon Cannabis, LLC. Vote – Yeas: Mayor Mahoney, Vice Mayor Robinson, Councilmembers Gunn, Schlecte, Bunnell, and Forgrave (6). Nays: Councilmember Dancy (1). Motion carried.

**K. Approve the purchase of one (1) 2023 Ford F450 XL Cab and Chassis 4x4 DRW regular cab and AIR FLO PSC 9-3 dump body through MiDeal**

**Recommendation:** *Approve the purchase of one (1) 2023 Ford F450 XL Cab and Chassis 4x4 DRW Regular Cab from Gorno Ford for the amount of \$54,589.00 and an AIR FLO PSC 9-3 dump body purchased through and installed by Automotive Service Company in the amount of \$21,213.17 for a total purchase amount of \$75,802.17 through MiDeal. A 10% contingency \$7,580.22 for a total amount of \$83,382.39.*

Motion was made by Councilmember Forgrave, seconded by Councilmember Schlecte to approve the purchase of one 2023 Ford F450 XL Cab and Chassis 4x4 DRW regular cab from Gorno Ford for the amount of \$54,589.00 and AIR FLO PSC 9-3 dump body purchased through and installed by Automotive Service Company in the amount of \$21,213.17 for a total purchase amount of \$75,802.17 through MiDeal. Vote - Yeas: Mayor Mahoney, Vice Mayor Robinson, Councilmembers Dancy, Gunn, Schlecte, Bunnell, and Forgrave (7). Nays: none. Motion carried.

**L. Contract Award for 2023 Major Street Engineering**

**Recommendation:** *Approve an award for the 2023 Major Street Engineering contract to Rowe Professional Service Company of Flint, Michigan in the amount of \$145,678.05 and authorize the Mayor and City Clerk to execute the appropriate document(s) in accordance with the Purchasing Agent.*

Motion was made by Councilmember Schlecte, seconded by Councilmember Gunn to approve the contract award for 2023 Major Street Engineering. Vote - Yeas: Mayor Mahoney, Vice Mayor Robinson, Councilmembers Dancy, Gunn, Schlecte, Bunnell, and Forgrave (7). Nays: none. Motion carried.

**M. Contract Award for 2023 Lansing Avenue Corridor Engineering**

**Recommendation:** *Approve the award for the 2023 Lansing Avenue Corridor Engineering contract to Hubbell, Roth & Clark, Inc. of Jackson, Michigan in the amount of \$452,451.30 and authorize the Mayor and City Clerk to execute the appropriate document(s) in accordance with the Purchasing Agent.*

Motion was made by Councilmember Schlecte, seconded by Councilmember Dancy to approve the contract award for 2023 Lansing Avenue Corridor Engineering in the amount of \$452,451.30. Vote - Yeas: Mayor Mahoney, Vice Mayor Robinson, Councilmembers Dancy, Gunn, Schlecte, Bunnell, and Forgrave (7). Nays: none. Motion carried.

**N. Consider first reading on amendment to Article VI, Division 2, Sec. 18-156 of the City Code to correct scrivener's error**

**Recommendation:** *Consider first reading of amendment to Section 18-156. Possession/use of Marihuana, of the City of Jackson Code of Ordinances.*

Motion was made by Councilmember Gunn, seconded by Councilmember Schlecte to consider the first reading on amendment to Article VI, Section 18-156 of the City Code to correct a scrivener's error. Vote - Yeas: Mayor Mahoney, Vice Mayor Robinson, Councilmembers Gunn, Schlecte, Bunnell, and Forgrave (6). Nays: Councilmember Dancy (1). Motion carried.

**O. Consider first reading on amendment to Chapter 2, Article VI, sec 2-451, record and data retention, of the City Code**

**Recommendation:** *Approve amendment to Section 2-451 of Chapter 2, Article IV of the Jackson Code of Ordinances.*

Motion was made by Councilmember Schlecte, seconded by Vice Mayor Robinson to consider the first reading on amendment to Chapter 2, Article VI, Section 2-451, Record and Data Retention of the City Code. Vote - Yeas: Mayor Mahoney, Vice Mayor Robinson, Councilmembers Dancy, Gunn, Schlecte, Bunnell, and Forgrave (7). Nays: none. Motion carried.

**P. Approve the sale of City owned property located at 109 Hollywood for \$11,000**

**Recommendation:** *Approve the sale of City owned property located at 109 Hollywood St, to Luis Tejada for \$11,000. Authorize the City Manager to sign all sale documents associated with the Property Transfer and to make minor modifications.*

Motion was made by Councilmember Schlecte, seconded by Councilmember Bunnell to approve the sale of City owned property located at 109 Hollywood for \$11,000. Vote - Yeas: Mayor Mahoney, Vice Mayor Robinson, Councilmembers Dancy, Gunn, Schlecte, Bunnell, and Forgrave (7). Nays: none. Motion carried.

**Q. Amendment to Chapter 28 of the City of Jackson Zoning Ordinance**

**Recommendation:** *Consider amendments as presented.*

Motion was made by Councilmember Schlecte, seconded by Councilmember Forgrave for an amendment to Chapter 28 of the City of Jackson Zoning Ordinance. Vote - Yeas: Mayor Mahoney, Vice Mayor Robinson, Councilmembers Dancy, Gunn, Schlecte, Bunnell, and Forgrave (7). Nays: none. Motion carried.

**CITY COUNCILMEMBER'S COMMENTS:**

Mayor Mahoney, Vice Mayor Robinson, Councilmembers Dancy, Gunn, Schlecte, Bunnell all offered comments. Councilmember Forgrave declined to offer comments.

**MANAGER'S COMMENTS:**

City Manager Jonathan Greene declined to offer comments.

**ADJOURNMENT:**

No further business being offered, a motion to adjourn was made by Councilmember Dancy, seconded by Councilmember Schlecte. Vote was done by voice with all in favor. Mayor Mahoney adjourned the meeting at 8:09 p.m.

**MEMO TO:** Honorable Mayor Mahoney and City Councilmembers

**FROM:** Matthew M. Hagerty, City Attorney

**DATE:** January 24, 2023 City Council Meeting

**SUBJECT:** Release of Jackson Police Department K9 to Det. Michael Galbreath

---

**RECOMMENDATION:** **Approve attached Resolution authorizing the release of Jackson Police Department K9 "Gleeson" to Det. Michael Galbreath**

Your consideration is appreciated.

## DEPARTMENT REPORT

**MEMO TO:** Honorable Mayor Mahoney and City Councilmembers

**FROM:** Matthew M. Hagerty, City Attorney

**DATE:** January 24, 2023 City Council Meeting

**RECOMMENDATION:** **Approve attached Resolution authorizing the release of JPD K9 “Gleeson” to Det. Michael Galbreath**

### SUMMARY

Jackson Police Department Detective Michael Galbreath is the assigned handler for JPD’s K-9 “Gleeson”. Gleeson has reached a point in his life that it is now time to take him out of active service as a police canine. Consistent with past practice, it is the opinion of the Director of Police and Fire Services Elmer Hitt and Deputy Director Sergio Garcia that Gleeson be released to Det. Galbreath to be his personal pet.

### HISTORY, BACKGROUND AND DISCUSSION

Pursuant to a prior City Council Resolution adopted on December 3, 1997 and the City’s Purchasing Policy, City property must be offered for public sale when no longer required for public purposes. The situation of a police canine, while technically a personal property asset, is clearly unique. It is therefore recommended that the normal procedures for City property disposition should not be followed in the case of such a highly trained police canine. As a result, it is my recommendation to deviate from the requirements of the public sale process and allow Det. Galbreath to retain Gleeson as his personal pet. City Council has previously permitted a similar request by way of Resolution as recently as April of 2015, when “Zygos” was retired and given to retired officer Steve Scarpino. A similar Resolution to accomplish this for Det. Galbreath is attached.

### POSITION

I recommend the attached Resolution be approved.

**ATTACHMENTS:** Resolution.

**RESOLUTION**

**BY THE CITY COUNCIL:**

**WHEREAS**, the City of Jackson has in its possession a police canine named Gleeson that is used by the Jackson Police Department to assist in police duties in the K9 unit as needed;

**WHEREAS**, Gleeson has been professionally trained and handled throughout his service with the Jackson Police Department by Detective Michael Galbreath;

**WHEREAS**, Detective Galbreath cares for the canine during times when Gleeson is not in active duty;

**WHEREAS**, Gleeson has reached the end of his useful life as a police canine;

**WHEREAS**, Detective Galbreath wishes to keep Gleeson as his personal pet and care for the dog in the future; and

**WHEREAS**, City of Jackson wishes to permit Detective Galbreath to keep Gleeson as his personal pet and to recognize Gleeson for his service to the citizens of the City of Jackson.

**NOW, THEREFORE, BE IT RESOLVED** that the City of Jackson hereby gives and releases the canine Gleeson to Detective Michael Galbreath and recognizes Det. Galbreath and Gleeson for their collective service to the citizens of the City of Jackson as part of the Jackson Police Department’s K9 unit.

State of Michigan )  
County of Jackson ) ss  
City of Jackson )

I, Andrea Muray, City Clerk in and for the City of Jackson, State of Michigan, do hereby certify that the foregoing is a true and complete copy of a Resolution adopted by the Jackson City Council on the 24<sup>th</sup> day of January, 2023.

IN WITNESS WHEREOF, I have hereto affixed my signature and the seal of the City of Jackson, Michigan, on this \_\_\_ day of January, 2023.

\_\_\_\_\_  
Andrea Muray  
City Clerk

**MEMO TO:** Honorable Mayor and City Councilmembers  
**FROM:** Andrea Muray, City Clerk  
**DATE:** January 24, 2023  
**SUBJECT:** Local Governing Body Resolution for Charitable Gaming License – Lean Rocket Lab

---

**RECOMMENDATION:**

Consideration of approval of the Local Governing Body Resolution for Charitable Gaming Licenses for Lean Rocket Lab. For your review a copy of the State application as well as Frequently Asked Questions are included.

Your consideration and concurrence is appreciated.

C: Jonathan Greene, City Manager

### QUALIFICATION INFORMATION

Complete this form and submit with the required qualification documents listed on the attached Qualification Requirements sheet. A Bingo, Raffle, or Charity Game Ticket license application and fee may also be submitted with this information. See box #5 below for mailing instructions.

#### 1. ORGANIZATION INFORMATION

Organization Name <b>LEAN ROCKET LAB</b>			
Organization Physical Street Address <b>133 W MICHIGAN AVE.</b>			
City <b>JACKSON</b>	State <b>MI</b>	Zip Code <b>49201</b>	County
Organization Mailing Address <b>133 W MICHIGAN AVE.</b>			<input checked="" type="checkbox"/> Same as Physical Address
City	State	Zip Code	County
Organization Telephone Number <b>517-395-4151</b>			

#### 2. ORGANIZATION PURPOSE

Briefly describe the purpose of your organization.  
**Jackson, MI Entrepreneurial Hub: Space, services & resources for entrepreneurs & innovators**

#### 3. LICENSE APPLICATION

Enclosed is a completed application and fee for a  Bingo  Raffle  Charity Game Ticket license  
 Make checks payable to STATE OF MICHIGAN.

#### 4. AUTHORIZED CONTACT PERSON

First Name <b>CHRISTIE</b>	Last Name <b>MYERS</b>	Position/Role with Organization <b>MANAGER</b>	
Mailing Address <b>4033 MAGNOLIA PKWY</b>		City <b>JACKSON</b>	
State <b>MI</b>	Zip Code <b>49201</b>	Telephone Number (Day) <b>810-223-1229</b>	Telephone Number (Evening)
By signing below, I hereby certify that the representations, information, and data presented are true, accurate, and complete to the best of my knowledge. I understand that failure to answer truthfully, completely, and accurately could preclude the organization from receiving an approval to obtain a gaming license.			
Authorized Contact Person Signature <b>C. Myers</b>		Date <b>1-17-23</b>	
Print Authorized Contact Name and Title <b>Christie Myers, Manager of LOCAL</b>			

#### 5. MAILING INSTRUCTIONS

Mail this completed Qualification Information form, the required qualification documentation listed on the Qualification Requirements sheet, and the completed license application and fee (if also applying for a gaming license) to Charitable Gaming Division, PO Box 30023, Lansing, MI 48909. If submitting by overnight carrier (FedEx, UPS, etc.), send to Charitable Gaming Division, 101 East Hillsdale, Lansing, MI 48933.





Charitable Gaming Division  
 Box 30023, Lansing, MI 48909  
 OVERNIGHT DELIVERY:  
 101 E. Hillsdale, Lansing MI 48933  
 (517) 335-5780  
 www.michigan.gov/cg

**LOCAL GOVERNING BODY RESOLUTION FOR CHARITABLE GAMING LICENSES**  
 (Required by MCL.432.103(K)(ii))

At a \_\_\_\_\_ meeting of the \_\_\_\_\_  
REGULAR OR SPECIAL TOWNSHIP, CITY, OR VILLAGE COUNCIL/BOARD

called to order by \_\_\_\_\_ on \_\_\_\_\_  
DATE

at \_\_\_\_\_ a.m./p.m. the following resolution was offered:  
TIME

Moved by \_\_\_\_\_ and supported by \_\_\_\_\_

that the request from \_\_\_\_\_ of \_\_\_\_\_,  
NAME OF ORGANIZATION CITY

county of \_\_\_\_\_, asking that they be recognized as a  
COUNTY NAME

nonprofit organization operating in the community for the purpose of obtaining charitable

gaming licenses, be considered for \_\_\_\_\_.  
APPROVAL/DISAPPROVAL

**APPROVAL**

**DISAPPROVAL**

Yeas: \_\_\_\_\_

Yeas: \_\_\_\_\_

Nays: \_\_\_\_\_

Nays: \_\_\_\_\_

Absent: \_\_\_\_\_

Absent: \_\_\_\_\_

I hereby certify that the foregoing is a true and complete copy of a resolution offered and  
 adopted by the \_\_\_\_\_ at a \_\_\_\_\_  
TOWNSHIP, CITY, OR VILLAGE COUNCIL/BOARD REGULAR OR SPECIAL

meeting held on \_\_\_\_\_.  
DATE

SIGNED: \_\_\_\_\_  
TOWNSHIP, CITY, OR VILLAGE CLERK

PRINTED NAME AND TITLE

ADDRESS

COMPLETION: Required.  
 PENALTY: Possible denial of application.  
 BSL-CG-1152/06/001

## Frequently Asked Questions for Millionaire Party Events

### Becoming a Qualified Organization

***Q: How do I know whether my organization needs to become qualified to host a Millionaire Party event?***

**A:** All organizations must be qualified through the Michigan Gaming Control Board (MGCB) to hold an event. If your organization has never conducted a licensed Millionaire Party event or has not held a licensed Millionaire Party event during the past five or more years, please refer to the [qualifications process](#) on the MGCB website. At times, the Board may require an already qualified organization to submit updated documentation to maintain qualification status.

***Q: What types of organizations may become qualified with the Board?***

**A:** An organization may be eligible to become qualified if it is a bona fide religious, educational, service, senior citizens, fraternal or veterans' organization operating without profit to its members. Additionally, it must either have existed continuously as an organization for a period of five years or is exempt from taxation under section 501(c) of the Internal Revenue code.

***Q: What category of organization would my group fall under?***

**A:** Some examples of organizations qualified with the MGCB are:

**Religious** – churches

**Educational** – schools, including public, private and charter

**Service** – Kiwanis Club, Lions Club

**Service (Local Civic)** – sports clubs, school groups, animal rescues, auxiliary groups

**Senior Citizens** – organizations with at least 15 members over the age of 60 that exist for the mutual support and advancement of the causes of elderly or retired persons

**Fraternal** – Eagles, Shriners, K of C, Knights of Templar

**Veterans** – VFW, AMVETS

The definition of the organization type is displayed at the bottom of the requirements page of each application type. Please review the definition when choosing which application to submit to ensure it applies to the organization.

***Q: How does my organization become a qualified organization with the Michigan Gaming Control Board?***

**A:** Organizations must complete a [Millionaire Party Qualification Form](#) and provide required documents including but not limited to bylaws, Articles of Incorporation, bank statements, financial documents and Internal Revenue Service tax exempt status. In addition, a mandatory on-site meeting between the organization's officers and a representative of the MGCB is required.

**Note:** Please allow a minimum of eight weeks' processing time after all requested documents have been received. You must be a qualified organization prior to applying for a Millionaire Party event license.

***Q: Is there a fee to become a qualified organization?***

**A:** No, there is no fee to become a qualified organization. However, a license fee is charged for holding a licensed Millionaire Party event.

### **Millionaire Party Event Application**

***Q: How does my organization apply for a Millionaire Party event?***

**A:** If you recently completed the qualification process, you must FIRST receive notice from the MGCB indicating the qualification review is complete and your organization is now considered a qualified organization. To apply for a Millionaire Party event, a qualified organization must complete and submit an event application a minimum of six weeks before the proposed event date along with the appropriate fee (\$50 per event day). The organization must provide required documents with the application such as a demarcated area diagram, location rental agreement, equipment provider agreement, and workers' list. If you are a Millionaire Party (MP) portal user, you may apply within the portal. A link to the MP portal may be found on the MGCB Millionaire Party Event Application [page](#).

***Q: How many licensed events can my organization host annually?***

**A:** A qualified organization may receive up to four licenses per calendar year. Each license may be issued for up to four consecutive days per event and costs \$50 per day. For example, if you elect to have a four-day event, your license fee will be \$200.

***Q: Where can I hold my event?***

**A:** The event can be held at your organization's own location, or your organization may choose to rent a facility to hold your event. The event location must be indicated on your Millionaire Party Event Application for approval.

***Q: How can I see the status of my Millionaire Party license application?***

**A:** You may check the [License Application Status Lookup tool](#) on our website for a current status on your application. A link to this tool also may be found on the MGCB Millionaire Party [home page](#). If you are a MP portal user, you can review the application tabs to see your event's status. A licensed event will be displayed on the Licensed tab in the MP portal.

### **Event Staffing**

***Q: Who can work/assist at the event?***

**A:** Under the MGCB's Administrative Rules ([R432.310\(6\)](#)), the qualified organization shall have at least two bona-fide members over the age of 18 working an event at all times. The organization will designate at least one of those persons as the chairperson. The chairperson is in charge and responsible for the conduct of the licensed gaming event. The two members must be listed on Attachment A of the event application along with their home addresses, roles in the organization, and telephone numbers.

In addition, if your organization is a directorship, only Board Members may chair and work the event.

***Q: Who can be chairperson at my event?***

**A:** The chairperson must be a bona fide member of the qualified organization for at least six months, over the age of 18 and serves as a millionaire party chairperson for only one qualified organization in a calendar year. If your organization is a school, the chairperson must be a staff member. If your organization is a directorship, only a Board Member may be a chairperson.

***Q: Is there an age requirement to work at an event?***

**A:** Event workers must be 18 years of age or older. Anyone participating in the event, including players, must be 18 years of age or older.

***Q: Who can be a dealer at my event?***

**A:** A qualified organization may have its own bona fide members serve as dealers at a millionaire party event, or it may hire dealers from a licensed supplier. If using your own members as dealers, the event application must include a list of the dealers who will work at the proposed event (on Attachment B). The Millionaire Party event application may be denied if a dealer has ever been convicted of, forfeited bond upon a charge of, or pled guilty to the following:

- (a) A felony
- (b) A gambling offense
- (c) Criminal fraud
- (d) Forgery

- (e) Larceny
- (f) Filing a false report with a governmental agency

### **Changes: Event Changes, Cancelations and Organizational Changes**

#### ***Q: How do I request a change for my Millionaire Party event?***

**A:** A qualified organization must submit a [License Change Form](#) to request a change in the location, supplier and event date and/or time no less than 20 days before the event start date. If you are a MP portal user, you may submit a request to edit your event from the Pending MGCB Decision or Licensed tab no less than 20 days before the event start date.

#### ***Q: How do I cancel my Millionaire Party event?***

**A:** If cancelled, a qualified organization must notify the MGCB **prior** to the event in writing. An email may be sent to [millionaireparty@michigan.gov](mailto:millionaireparty@michigan.gov). If the event license already has been issued, you must return the original license with your request. A refund then will be issued for the license fee. If you are a MP portal user, you may submit a request to withdraw from the Pending MGCB Decision tab or Cancel Event from the Licensed tab. The request must be made prior to the event.

#### ***Q: Do I have to notify the MGCB whenever our principal officer changes?***

**A:** Yes, please complete a [Qualified Organization Information Change Form](#) found on our website to update the information. Each principal officer also must review the [Millionaire Party Guide for Qualified Organizations \(Charities\)](#) and sign a Certificate of Completion.

#### ***Q: How does my organization update the MGCB on changes such as our address, officers or by-laws?***

**A:** Complete the [Qualified Organization Information Change Form](#) to update organization information. If changes or updates have occurred on the Qualified Organization's legal documents (e.g., by-laws or Articles of Incorporation), please submit the updated documents to the MGCB. To use the MP Portal, complete the [Officer/Contact Information](#) form.

### **General Information**

#### ***Q: How can I stay informed about Millionaire Party Events?***

**A:** You can stay informed by checking the MGCB website for the latest news and updated forms and subscribing to [MGCB Millionaire Party emails](#).

***Q: How do I file a complaint regarding the conduct of a licensed charitable gaming event?***

**A:** A [complaint or tip](#) may be submitted to the MGCB by using a form on the website, emailing [MiGamblingTip@michigan.gov](mailto:MiGamblingTip@michigan.gov) or by calling 888-314-2682. Please complete your complaint with as much information as possible, including the licensee's name, license number, date and location of the event and a written explanation of the misconduct. You also may send the completed complaint to the MGCB via mail to:

Michigan Gaming Control Board  
Office of the Executive Director  
3062 W. Grand Boulevard Suite L-700  
Detroit, MI 48202-6062

**Note:** If you want your name to remain confidential, please indicate your request. (Email notifications are not anonymous.)

To report suspicious or illegal gambling-related activity anonymously, call 888-314-2682. You also may visit the [MGCB website](#) for more information.

**From:** Kenneth Robinson <kenneth.robinson@jpsk12.org>  
**Date:** January 21, 2023 at 5:04:27 PM EST  
**To:** Daniel Mahoney <dmahoney@cityofjackson.org>  
**Subject:** Letter of resignation

Dear Mayor Mahoney and the Housing Committee:

Due to my day job schedule, I am unable to be a member of the affordable housing committee. Please accept this email/letter as my formal notice of resignation from my position with the affordable housing committee.

Thank you for the opportunity that was provided to me.

Kenneth Robinson  
1042 Williams St  
Jackson, Michigan 49203  
517-795-3304

Click [here](#) to report this email as spam.

**MEMO TO:** City Councilmembers

**FROM:** Daniel Mahoney, Mayor

**DATE:** January 24, 2023

**SUBJECT:** Appointment to Affordable Housing Development Board

---

**RECOMMENDATION:**

**Approve the Mayor's recommendation to appoint Toby Berry to the Affordable Housing Development Board for a five-year term, beginning immediately and ending on December 31, 2027.**

Your concurrence and consideration is appreciated.

DM:imm

**Lisa Moutinho**

---

**From:** noreply@civicplus.com  
**Sent:** Tuesday, January 4, 2022 11:29 AM  
**To:** Daniel Mahoney; John Willis; Aaron Dimick; Lisa Moutinho  
**Subject:** Online Form Submittal: City of Jackson Board/Commission Application

### City of Jackson Board/Commission Application

#### City of Jackson Board/Commission Application

First Name	Toby
Last Name	Berry
Address	1744 Plateau Dr
City	Jackson
State	MI
Zip	49203
Phone Number	517-745-0322
Email	tberry@caajlh.org
Last four digits of Social Security Number	
Occupation	Chief Executive Officer of Community Action Agency
Describe your community involvement.	I have been an employee of Community Action Agency for over 20 years. In my various roles I have participated in many community development projects and grassroots organizing projects in the City of Jackson. I am an active member of Residents in Action and partner with many local organizations. I work closely with both local residents and elected officials and am a member of the Jackson Continuum of Care.
Are you a City of Jackson resident? Being a non-resident does not prevent you from serving on a board or commission. However, some boards and commissions have residency requirements.	No

If you answered "No" where do you reside?	Summit Township
If you answered "Yes" how long have you been a City resident?	Field not completed.
Which board or commission are you interested in? You may choose more than one.	Affordable Housing Development Board
If you selected the Civil Service Board, are you a registered voter? Only registered voters can serve on this commission.	Field not completed.
Why do you want to serve on your selected board or commission?	I was a supporter of the creation of this ordinance and believe that a coordinated approach to addressing the housing needs in the City of Jackson is necessary for success. I understand the need for a variety of housing options in order for places to thrive and believe that my experience and knowledge can be an asset to the board.
Upload additional documents	<a href="#">Toby L Berry 2021.pdf</a>

(Section Break)

#### Appointment Process

*Following the submission of your completed application, it will be reviewed by the City Manager's Office and the City Treasurer's Office. The Treasurer will review your application to ensure you do not owe the City unpaid taxes or fines. After that clearance, the Mayor will review your application and make a recommendation for an appointment to a board or commission by the City Council. If the recommendation is confirmed by the City Council, you may officially start the process of becoming a member of a board or commission.*

(Section Break)

#### City Charter Section 2.15. - Person in Default to the City.

*The city shall not contract with, or give an appointive position to, one who is in default to the city. No person who is in default to the city may accept or hold an elective or appointive position unless the default is resolved. Written notice describing the default shall be filed with the clerk and verified by the treasurer and served upon the candidate before the oath of office is given, or upon the officeholder. The term "default" shall not apply if the candidate or officeholder shall, within 30 days after receiving the notice, resolve the default, or if the person shall contest it by any recognized means of legal procedure before a court or tribunal of competent jurisdiction. In the event the indebtedness is upheld, the person shall have 30 days after final determination of the obligation is made to pay it in full.*

(Section Break)

---

**Final Submission**

*Completed applications are kept on file for up to one year after submission. You will be contacted using the information you provided if you are selected for final consideration by the City Council. A board or commission appointment is a non-paid volunteer position.*

---

Digital Signature                      Toby Berry

---

Date of Submission                      1/4/2022

---

Email not displaying correctly? [View it in your browser.](#)

Click [here](#) to report this email as spam.

**MEMO TO:** City Councilmembers  
**FROM:** Daniel Mahoney, Mayor  
**DATE:** January 24, 2023  
**SUBJECT:** Appointment to Environmental Commission

---

**RECOMMENDATION:**

Approve the Mayor's recommendation to appoint Conner Wood as the City Planning Commission's representative on the Environmental Commission for a concurrent term, beginning immediately and expiring on December 31, 2025.

Your consideration and concurrence is appreciated.

DM:lm

**From:** noreply@civicplus.com  
**Sent:** Wednesday, January 11, 2023 11:26 AM  
**To:** Daniel Mahoney; John Willis; Aaron Dimick; Lisa Moutinho; Leticia Albarran  
**Subject:** Online Form Submittal: City of Jackson Board/Commission Application

## City of Jackson Board/Commission Application

### City of Jackson Board/Commission Application

First Name	Conner
Last Name	Wood
Address	319 N Bowen St
City	Jackson
State	MI
Zip	49202
Phone Number	9894449151
Email	cmmwood@gmail.com
Last four digits of Social Security Number	
Occupation	Deputy Chief of Staff, Michigan AFL-CIO
Describe your community involvement.	Chair, City of Jackson Planning Commission January 2018–Present Board Secretary, United Way of Jackson County / United Way of South Central Michigan February 2020–Present Member, Jackson County Branch NAACP #3142 Spring 2018–Present Member, City of Jackson Elections Commission January 2022–Present Member, People for the Parks & Trails of Jackson, Michigan March 2022–Present Member, City of Jackson Charter Review Committee Jan. 2018–June 2020
Are you a City of Jackson resident? Being a non-resident does not prevent	Yes

you from serving on a board or commission. However, some boards and commissions have residency requirements.

---

If you answered "No" where do you reside? *Field not completed.*

---

If you answered "Yes" how long have you been a City resident? 6 years

---

Which board or commission are you interested in? You may choose more than one. Ella W. Sharp Park Board of Trustees, Environmental Commission , Parks and Recreation Commission

---

If you selected the Civil Service Board, are you a registered voter? Only registered voters can serve on this commission. *Field not completed.*

---

Why do you want to serve on your selected board or commission? Environmental Commission: The Planning Commission is supposed to have a member serve as a liaison between the Planning Commission and Environmental Commission. As Planning Commission Chair, I would be happy to serve as that liaison if appointed.  
Ella / Parks: As a member of the People for the Parks & Trails, I'd like to help our parks in any way I can.

---

Upload additional documents *Field not completed.*

---

(Section Break)

#### Appointment Process

*Following the submission of your completed application, it will be reviewed by the City Manager's Office and the City Treasurer's Office. The Treasurer will review your application to ensure you do not owe the City unpaid taxes or fines. After that clearance, the Mayor will review your application and make a recommendation for an appointment to a board or commission by the City Council. If the recommendation is confirmed by the City Council, you may officially start the process of becoming a member of a board or commission.*

---

(Section Break)

---

**City Charter Section 2.15. - Person in Default to the City.**  
*The city shall not contract with, or give an appointive position to, one who is in default to the city. No person who is in default to the city may accept or hold an*

*elective or appointive position unless the default is resolved. Written notice describing the default shall be filed with the clerk and verified by the treasurer and served upon the candidate before the oath of office is given, or upon the officeholder. The term "default" shall not apply if the candidate or officeholder shall, within 30 days after receiving the notice, resolve the default, or if the person shall contest it by any recognized means of legal procedure before a court or tribunal of competent jurisdiction. In the event the indebtedness is upheld, the person shall have 30 days after final determination of the obligation is made to pay it in full.*

---

(Section Break)

---

**Final Submission**

*Completed applications are kept on file for up to one year after submission. You will be contacted using the information you provided if you are selected for final consideration by the City Council. A board or commission appointment is a non-paid volunteer position.*

---

Digital Signature                      Conner Wood

---

Date of Submission                      1/11/2023

---

Email not displaying correctly? [View it in your browser.](#)

Click [here](#) to report this email as spam.

**MEMO TO:** City Councilmembers  
**FROM:** Daniel Mahoney, Mayor  
**DATE:** January 24, 2023  
**SUBJECT:** Appointment to the Historic District Commission

---

**RECOMMENDATION:**

**Approve the Mayor's recommendation to appoint Jacob Stressman to the Historic District Commission for a term of three years beginning immediately and ending on December 31, 2025.**

In accordance City Code, Sec. 13-5, MCL 399.204, the Mayor appoints, subject to City Council confirmation, seven City residents for three-year terms. Mayor shall consult with Chair of the Historic District Commission and appoint at least two members from a list of citizens submitted by a duly organized and existing local historical and/or preservation society(s) and, if available, one architect or a graduate of an accredited school of architecture who has two years of architecture experience or who is an architect registered in this state.

It is my desire, therefore, to appoint Jacob Stressman to the Historic District Commission for a three-year term, beginning immediately and ending on December 31, 2025.

Your consideration and concurrence is appreciated.

DM:imm

**From:** noreply@civicplus.com  
**Sent:** Wednesday, December 28, 2022 9:22 PM  
**To:** Daniel Mahoney; John Willis; Aaron Dimick; Lisa Moutinho; Leticia Albarran  
**Subject:** Online Form Submittal: City of Jackson Board/Commission Application

## City of Jackson Board/Commission Application

### City of Jackson Board/Commission Application

First Name	Jacob
Last Name	Stressman
Address	1700 SOUTH WEST AVENUE, M3
City	JACKSON
State	MI
Zip	49203
Phone Number	517.74.6561
Email	jacobstressman@yahoo.com
Last four digits of Social Security Number	
Occupation	Coordinator- Jackson County Adult Treatment Court
Describe your community involvement.	<p>Living and working in the city of Jackson has provided me with several opportunities for community involvement with agencies such as, the YMCA of Jackson, Salvation Army of Jackson, Retired Senior Volunteer Program, Victim Rights, and Drug Free Jackson. I believe engaging with local organizations is an important way to create local networks, discuss concerns, empower and integrate people, and most importantly, create solutions.</p> <p>One of the most rewarding experiences of my life was creating the Friends of Recovery Court 501(c)3 to assist participants of the Jackson County Adult Treatment Court (formerly Jackson County Recovery Court) to overcome barriers and assist in long-term recovery. As executive director, I have aided the Friends of Recovery Court in expanding services to provide ancillary needs such as, treatment, dental/medical care, child</p>

care, transportation support, education and training expenses as well as temporary housing.

---

Are you a City of Jackson resident? Being a non-resident does not prevent you from serving on a board or commission. However, some boards and commissions have residency requirements.

Yes

---

If you answered "No" where do you reside?

Field not completed.

---

If you answered "Yes" how long have you been a City resident?

30+ years

---

Which board or commission are you interested in? You may choose more than one.

Historic District Commission , Parks and Recreation Commission

---

If you selected the Civil Service Board, are you a registered voter? Only registered voters can serve on this commission.

Yes

---

Why do you want to serve on your selected board or commission?

As a life-long resident of the city of Jackson, I have an enthusiasm for improving the quality of life in our community. Community boards serve as a critical link between city officials, staff, and the public and I believe by serving on a community board, I will be able to engage in civic matters that can make a difference while fulfilling a community responsibility. Serving on a board will also provide me with an opportunity to become a participant in the municipal government process and a chance to learn more about the inner-workings of local government from the ground up.

---

Upload additional documents

Field not completed.

---

(Section Break)

---

**Appointment Process**

*Following the submission of your completed application, it will be reviewed by the City Manager's Office and the City Treasurer's Office. The Treasurer will review your application to ensure you do not owe the City unpaid taxes or fines. After that clearance, the Mayor will review your application and make a recommendation for an appointment to a board or commission by the City Council. If the recommendation is confirmed by the City Council, you may officially start the process of becoming a member of a board or commission.*

---

(Section Break)

---

**City Charter Section 2.15. - Person in Default to the City.**

*The city shall not contract with, or give an appointive position to, one who is in default to the city. No person who is in default to the city may accept or hold an elective or appointive position unless the default is resolved. Written notice describing the default shall be filed with the clerk and verified by the treasurer and served upon the candidate before the oath of office is given, or upon the officeholder. The term "default" shall not apply if the candidate or officeholder shall, within 30 days after receiving the notice, resolve the default, or if the person shall contest it by any recognized means of legal procedure before a court or tribunal of competent jurisdiction. In the event the indebtedness is upheld, the person shall have 30 days after final determination of the obligation is made to pay it in full.*

---

(Section Break)

---

**Final Submission**

*Completed applications are kept on file for up to one year after submission. You will be contacted using the information you provided if you are selected for final consideration by the City Council. A board or commission appointment is a non-paid volunteer position.*

---

Digital Signature                      Jacob R. Stressman

---

Date of Submission                      12/28/2022

---

Email not displaying correctly? [View it in your browser.](#)

Click [here](#) to report this email as spam.

**MEMO TO:** City Councilmembers  
**FROM:** Daniel Mahoney, Mayor  
**DATE:** January 24, 2023  
**SUBJECT:** Appointment to Local Development Finance Authority/Brownfield Redevelopment Authority

---

**RECOMMENDATION:**

**Approve the Mayor's recommendation to appoint Finance Director Heather Ehnis to the Local Development Finance Authority/Brownfield Redevelopment Authority for a four-year term, beginning immediately and ending on June 3, 2026.**

In accordance with a Resolution adopted by the City Council on June 4, 1991, created by Authority, designated its boundaries and appointed members. (MCMLA 125.2152) Board consists of 11 members, seven appointed by the Mayor subject to City Council Confirmation. Members serve four-year terms.

It is my recommendation to approve the appointment of City of Jackson Finance Director Heather Ehnis to the Local Development Finance Authority/Brownfield Redevelopment Authority for a four-year term, beginning immediately and ending on June 3, 2026.

Your consideration and concurrence is appreciated.

DM:imm

**MEMO TO:** Honorable Mayor and City Councilmembers  
**FROM:** Andrea Muray, City Clerk  
**DATE:** January 24, 2023  
**SUBJECT:** Second Reading/Final Adoption Ordinance No. 2023-01

---

**RECOMMENDATION:**

Approve the second reading/final adoption of an ordinance amending Chapter 18 – Offenses, Article VI – Offenses Against Public Morals, Division 2, Marihuana and Drug Paraphernalia to Correct Section 18-156.

Ordinance No. 2023-01 was advanced to a second reading at the January 10, 2023 Council Meeting.

Your consideration and concurrence is appreciated.

C: Jonathan Greene, City Manager

---

ORDINANCE NO. 2023-01

AN ORDINANCE OF THE CITY OF JACKSON, MICHIGAN TO AMEND CHAPTER 18 – OFFENSES, ARTICLE VI – OFFENSES AGAINST PUBLIC MORALS, DIVISION 2, MARIHUANA AND DRUG PARAPHERNALIA TO CORRECT SECTION 18-156.

THE PEOPLE OF THE CITY OF JACKSON ORDAIN:

Section 1. Purpose.

The purpose of this Ordinance is to amend Chapter 18 – Offenses, Article VI – Offenses Against Public Morals, Division 2, Marihuana and Drug Paraphernalia, Sec. 18-156 to correct a scrivener’s error.

Section 2. That Chapter 18 – Offenses, Article VI – Offenses Against Public Morals, Division 2, Marihuana and Drug Paraphernalia, Sec. 18-156 be amended to read as follows:

**Sec. 18-156. Possession/use of marihuana.**

No person shall knowingly and intentionally possess or use marihuana unless the use and possession of marihuana shall be ~~in~~ in compliance with the Medical Marihuana Facilities Licensing Act, the Michigan Medical Marihuana Act and the Michigan Regulation and Taxation of Marihuana Act, and all other provisions of the City of Jackson Code of Ordinances, as amended.

---

ORDINANCE NO. 2023-01

AN ORDINANCE OF THE CITY OF JACKSON, MICHIGAN TO AMEND CHAPTER 18 – OFFENSES, ARTICLE VI – OFFENSES AGAINST PUBLIC MORALS, DIVISION 2, MARIHUANA AND DRUG PARAPHERNALIA TO CORRECT SECTION 18-156.

THE PEOPLE OF THE CITY OF JACKSON ORDAIN:

Section 1. Purpose.

The purpose of this Ordinance is to amend Chapter 18 – Offenses, Article VI – Offenses Against Public Morals, Division 2, Marihuana and Drug Paraphernalia, Sec. 18-156 to correct a scrivener’s error.

Section 2. That Chapter 18 – Offenses, Article VI – Offenses Against Public Morals, Division 2, Marihuana and Drug Paraphernalia, Sec. 18-156 be amended to read as follows:

**Sec. 18-156. Possession/use of marihuana.**

No person shall knowingly and intentionally possess or use marihuana unless the use and possession of marihuana shall be in compliance with the Medical Marihuana Facilities Licensing Act, the Michigan Medical Marihuana Act and the Michigan Regulation and Taxation of Marihuana Act, and all other provisions of the City of Jackson Code of Ordinances, as amended.

Section 3. Effective Date.

This amended Ordinance takes effect thirty (30) days from the date of adoption.

The foregoing Ordinance No. 2023-01 was adopted by the Jackson City Council of the 24th day of January, 2023 and a summary published on January 29, 2023.

---

Daniel Mahoney, Mayor

---

Andrea Muray, City Clerk

**MEMO TO:** Honorable Mayor and City Councilmembers  
**FROM:** Andrea Muray, City Clerk  
**DATE:** January 24, 2023  
**SUBJECT:** Second Reading/Final Adoption Ordinance No. 2023-02

---

**RECOMMENDATION:**

Approve the second reading/final adoption of an ordinance amending Chapter 2, Article IV of the City of Jackson Code of Ordinances to revise the record disposal schedule for tax rolls and special assessment ledgers.

Ordinance No. 2023-02 was advanced to a second reading at the January 10, 2023 Council Meeting.

Your consideration and concurrence is appreciated.

C: Jonathan Greene, City Manager

## ORDINANCE NO. 2023-02

An Ordinance amending Chapter 2, Article IV of the City of Jackson Code of Ordinances to revise the record disposal schedule for tax rolls and special assessment ledgers.

THE PEOPLE OF THE CITY OF JACKSON ORDAIN:

Section 1. Purpose.

The City Council adopts this ordinance amending Section 2-451 of Chapter 2, Article IV of the City of Jackson Code of Ordinances to revise the record disposal schedule for tax rolls and special assessment ledgers.

Section 2. That Chapter 2, Article IV of the City of Jackson Code of Ordinances be amended as follows:

### **Chapter 2 – ADMINISTRATION**

#### **ARTICLE IV. – OPEN DATA AND PUBLIC RECORDS POLICY**

##### **Sec. 2-451. Information and record disposal schedule.**

- (a) The head of any city department is authorized to destroy or otherwise dispose of any record under his charge according to the following schedule:
- (1) *To be retained permanently:*
    - a. General ledgers, general journals and cash books.
    - b. Bond and interest ledgers and records of bonds and interest coupons destroyed.
    - c. Property ledgers.
    - d. Deeds and other title papers.
    - e. Records of tax liens, foreclosures and sales.
    - f. Records of securities owned or held in trust.
    - g. Records of employee earnings and payroll deductions.
    - h. Memoranda relating to outstanding warrants or checks not presented for payment, issue of duplicate checks.
    - i. Reports which include general ledger balance sheets, trial balances, payroll summaries and analyses of operating figures for a period longer than one (1) year.
    - j. Annual reports and summaries.
    - k. Correspondence, reports and memoranda of a policy nature.
    - l. Auditor's reports.
    - m. Charts of accounts and manuals of instruction.

- n. Birth and death certificates, burial permits, communicable disease records, immunization records, positive tests for syphilis.
  - o. Maps, records and plans of new construction or improvements and tracings of systems.
  - p. Clipping file.
  - q. Minutes of commissions, boards, councils, committees and other official groups.
  - r. Negative photographs.
  - s. Reference materials produced by in-house officials.
  - t. Assessment rolls, real and personal property.
  - u. Contracts and leases.
  - v. Agreements and contracts.
  - w. Plats and plat books.
  - x. Valuation records.
  - y. Deeds, land contracts, title abstracts.
  - z. Annual budget and financial statement.
  - aa. Answered alarm register.
  - bb. Fire violation notices.
  - cc. Legal opinions.
  - dd. Annexation and zoning data.
  - ee. Master plan reports.
  - ff. Urban renewal data.
  - gg. Surveyor field notebook.
  - hh. Job descriptions and salary schedules.
  - ii. Service hydrant and meter records.
  - jj. Police and district court records (unless otherwise provided by law).
- (2) *To be retained for twenty (20) years:*
- a. Tax rolls and special assessment ledgers.
- (3) *To be retained for fifteen (15) years:*
- a. Subsidiary ledgers, including revenue ledgers, appropriation expenditure ledgers, store ledgers, miscellaneous accounts and receivable ledgers.
  - b. Cost and work ledgers and records.
  - c. Journal vouchers.
  - d. Books of original entry (other than general journals and cash books) including voucher, warrant and check registers, daily summaries of receipts and their distribution, journal proof types from machine posting of subsidiary ledgers.
  - e. Paid or cancelled checks.
  - f. Surety bonds, officers and employees (fidelity bonds).
  - g. Fire investigation reports, fire training records.
  - h. Water department daily log sheets.

(4) *To be retained for seven (7) years:*

- a. City property appraisals.
- b. Duplicate receipts for taxes, special assessments, licenses, permits and registrations and building permit applications.
- c. Bank deposit books and record stubs.
- d. Paid or cancelled expenditure vouchers.
- e. Records of formal bids and advertising for bids on contracts and purchases where such procedure is required.
- f. Redeemed bonds and interest coupons (certificate of their destruction must be kept).
- g. Bond and interest register (bond and interest ledger shall be kept permanently).
- h. Insurance policies and records relating to claims.
- i. Records of collateral pledged by depositories.
- j. Memoranda relating to physical inventories.
- k. Correspondence, special subjects.
- l. Petitions.
- m. Income tax withholdings.
- n. Employee folders, and accident reports.
- o. Fire monthly summary, uniform allowance records.
- p. Parks and recreation attendance reports.
- q. Tree removals.
- r. Maintenance reports, state highway department.
- s. Vouchers with attached invoices.
- t. Recreation season and senior citizen programs.

(5) *To be retained for three (3) years:*

- a. Requisitions.
- b. Purchase orders.
- c. Shipping notices and bills of lading.
- d. Records of material received.
- e. Register of requisitions.
- f. Time tickets.
- g. Assignments, attachments and garnishments.
- h. Bank deposit slips and detailed records of items deposited.
- i. Negative laboratory reports.
- j. Property transfer slips.
- k. Tax statements.
- l. Departmental transfers.
- m. Tree plantings.

- (6) *[Other records not listed.]* All other records not appearing in the above schedules will be reviewed by the city attorney's office for the proper period of retention, but in no event shall the retention period be less than a year.
- (b) The time given in this schedule shall be figured from the end of the period covered by the record unless the record is subject to audit. In those cases, the time shall be figured from the date of the completed audit.

Section 3.      Effective Date.

This Ordinance takes effect in thirty (30) days.

The foregoing Ordinance No. 2023-02 was adopted by the Jackson City Council of the 24th day of January, 2023 and a summary published on January 29, 2023.

---

Daniel Mahoney, Mayor

---

Andrea Muray, City Clerk

ORDINANCE NO. 2023-\_\_\_\_\_

An Ordinance amending Chapter 2, Article IV of the City of Jackson Code of Ordinances to revise the record disposal schedule for tax rolls and special assessment ledgers.

THE PEOPLE OF THE CITY OF JACKSON ORDAIN:

Section 1. Purpose.

The City Council adopts this ordinance amending Section 2-451 of Chapter 2, Article IV of the City of Jackson Code of Ordinances to revise the record disposal schedule for tax rolls and special assessment ledgers.

Section 2. That Chapter 2, Article IV of the City of Jackson Code of Ordinances be amended as follows:

**Chapter 2 – ADMINISTRATION**

**ARTICLE IV. – OPEN DATA AND PUBLIC RECORDS POLICY**

**Sec. 2-451. Information and record disposal schedule.**

(a) The head of any city department is authorized to destroy or otherwise dispose of any record under his charge according to the following schedule:

(1) *To be retained permanently:*

- a. General ledgers, general journals and cash books.
- b. Bond and interest ledgers and records of bonds and interest coupons destroyed.
- ~~c. Tax rolls and special assessment ledgers.~~
- ~~cd.~~ Property ledgers.
- ~~de.~~ Deeds and other title papers.
- ~~ef.~~ Records of tax liens, foreclosures and sales.
- ~~fg.~~ Records of securities owned or held in trust.
- ~~gh.~~ Records of employee earnings and payroll deductions.
- ~~hi.~~ Memoranda relating to outstanding warrants or checks not presented for payment, issue of duplicate checks.
- ~~ij.~~ Reports which include general ledger balance sheets, trial balances, payroll summaries and analyses of operating figures for a period longer than one (1) year.
- ~~jk.~~ Annual reports and summaries.
- ~~kl.~~ Correspondence, reports and memoranda of a policy nature.
- ~~lm.~~ Auditor's reports.
- ~~mn.~~ Charts of accounts and manuals of instruction.

- ne. Birth and death certificates, burial permits, communicable disease records, immunization records, positive tests for syphilis.
- op. Maps, records and plans of new construction or improvements and tracings of systems.
- pe. Clipping file.
- qf. Minutes of commissions, boards, councils, committees and other official groups.
- rs. Negative photographs.
- st. Reference materials produced by in-house officials.
- tu. Assessment rolls, real and personal property.
- uv. Contracts and leases.
- vw. Agreements and contracts.
- wx. Plats and plat books.
- xy. Valuation records.
- yz. Deeds, land contracts, title abstracts.
- zaa. Annual budget and financial statement.
- aabb. Answered alarm register.
- bbee. Fire violation notices.
- ccdd. Legal opinions.
- ddee. Annexation and zoning data.
- eeff. Master plan reports.
- ffgg. Urban renewal data.
- gghh. Surveyor field notebook.
- hhii. Job descriptions and salary schedules.
- ijjj. Service hydrant and meter records.
- jjkk. Police and district court records (unless otherwise provided by law).

(2) To be retained for twenty (20) years:

a. Tax rolls and special assessment ledgers.

(32) To be retained for fifteen (15) years:

- a. Subsidiary ledgers, including revenue ledgers, appropriation expenditure ledgers, store ledgers, miscellaneous accounts and receivable ledgers.
- b. Cost and work ledgers and records.
- c. Journal vouchers.
- d. Books of original entry (other than general journals and cash books) including voucher, warrant and check registers, daily summaries of receipts and their distribution, journal proof types from machine posting of subsidiary ledgers.
- e. Paid or cancelled checks.
- f. Surety bonds, officers and employees (fidelity bonds).
- g. Fire investigation reports, fire training records.
- h. Water department daily log sheets.

(43) *To be retained for seven (7) years:*

- a. City property appraisals.
- b. Duplicate receipts for taxes, special assessments, licenses, permits and registrations and building permit applications.
- c. Bank deposit books and record stubs.
- d. Paid or cancelled expenditure vouchers.
- e. Records of formal bids and advertising for bids on contracts and purchases where such procedure is required.
- f. Redeemed bonds and interest coupons (certificate of their destruction must be kept).
- g. Bond and interest register (bond and interest ledger shall be kept permanently).
- h. Insurance policies and records relating to claims.
- i. Records of collateral pledged by depositories.
- j. Memoranda relating to physical inventories.
- k. Correspondence, special subjects.
- l. Petitions.
- m. Income tax withholdings.
- n. Employee folders, and accident reports.
- o. Fire monthly summary, uniform allowance records.
- p. Parks and recreation attendance reports.
- q. Tree removals.
- r. Maintenance reports, state highway department.
- s. Vouchers with attached invoices.
- t. Recreation season and senior citizen programs.

(54) *To be retained for three (3) years:*

- a. Requisitions.
- b. Purchase orders.
- c. Shipping notices and bills of lading.
- d. Records of material received.
- e. Register of requisitions.
- f. Time tickets.
- g. Assignments, attachments and garnishments.
- h. Bank deposit slips and detailed records of items deposited.
- i. Negative laboratory reports.
- j. Property transfer slips.
- k. Tax statements.
- l. Departmental transfers.
- m. Tree plantings.

|                   (65) *[Other records not listed.]* All other records not appearing in the above schedules will be reviewed by the city attorney's office for the proper period of retention, but in no event shall the retention period be less than a year.

- (b) The time given in this schedule shall be figured from the end of the period covered by the record unless the record is subject to audit. In those cases, the time shall be figured from the date of the completed audit.

Section 3.     Effective Date.

This Ordinance takes effect in thirty (30) days.

**MEMO TO:** Honorable Mayor and City Councilmembers  
**FROM:** Andrea Muray, City Clerk  
**DATE:** January 24, 2023  
**SUBJECT:** Second Reading/Final Adoption Ordinance No. 2023-03

---

**RECOMMENDATION:**

Approve the second reading/final adoption of an ordinance amending Chapter 28- Zoning of the City of Jackson Code of Ordinances.

Ordinance No. 2023-03 was advanced to a second reading at the January 10, 2023 Council Meeting.

Your consideration and concurrence is appreciated.

C: Jonathan Greene, City Manager

---

ORDINANCE NO. 2023-03

An Ordinance amending Chapter 28 – Zoning, Sections 28-5, 28-100, 28-130, and 28-253 to revise the definition of nonconforming lots, buildings, signs, structures, and uses of buildings, structures, and land.

THE PEOPLE OF THE CITY OF JACKSON ORDAIN:

Section 1. Purpose.

The City Council adopts this ordinance amending Sections 28-5, 28-100, 28-130, and 28-253, Chapter 28 of the City of Jackson Code of Ordinance to revise what is considered a nonconforming lot, building, sign, structure, and uses of buildings, structures, and land.

Section 2. That Chapter 28 of the City of Jackson Code of Ordinances be amended as follows:

**ARTICLE I. IN GENERAL**

**Sec. 28-5. – Definitions.**

*Structure* means anything constructed or erected, the use of which requires permanent location on the ground, or attachment to something having a permanent location on the ground.

**ARTICLE IV. SITE AND BUILDING DESIGN STANDARDS**

**Sec. 28-100. – Off-street parking, loading, and access design standards.**

(g) *Off-street parking space layout standards, construction and maintenance.*

(1) *Curbs.*

c. *Existing commercial and industrial use.* If the property is determined to be abandoned or discontinued for a period of twelve (12) consecutive months or more, or, if the damage, repair, alteration or improvement costs to the building or structure meets or exceeds one hundred (100) percent of the taxable value, or any expansion, reduction, resurfacing, replacement, or reconstruction of greater than or equal to twenty-five (25) percent of the existing designated off-street parking area then;

1. *Corner lots:* Curbing shall be required in all addressed and non-addressed front yards and designated side yards.

- 
2. *Interior lots:* Curbing shall be required for all parking areas located in the designated front yard and along public rights-of-way. At the discretion of the zoning administrator (or designee) curbing may be required for parking areas located in the designated side yard and rear yard based on the abutting or adjoining property use or condition.
  3. *All lots:* All interior islands and access aisles shall be curbed.

#### **ARTICLE V. DEVELOPMENT APPROVAL PROCEDURES**

#### **Sec. 28-130. - Nonconforming lots, buildings, signs, structures, and uses of buildings, structures and land.**

(a) *Purpose and Intent.*

- (1) *Nonconformities Permitted.* It is recognized that there exists within zoning districts, established by this Chapter, certain lots, buildings, structures, site improvements, and uses which were lawful before this Chapter was passed or amended, which would be prohibited, regulated, or restricted under the terms of this Chapter. It is the intent of this Chapter to permit these nonconforming lots, buildings, structures, and uses to continue until they are altered, abandoned, removed, or brought into conformance, but not to encourage their continued use or survival.
- (2) *Site Improvements.* Encourage gradual upgrading to a more conforming status of site and parking lot landscaping, parking (quantity and surface materials), paving/curbing, signage or other features of a site which were developed in compliance with the standards at the time of their construction, but which do not meet the current site plan or other standards of this Chapter and its amendments.
- (3) *No Expansion of Nonconformities.* Nonconforming lots, buildings, structures, and uses are hereby declared to be incompatible with the zoning districts in which they are located. It is the intent of this Chapter that these nonconformities shall not be enlarged upon, expanded, or extended, nor be used as grounds for adding other buildings, structures or uses prohibited elsewhere in the zoning district, except as may be provided for in this Chapter.
- (4) *Construction Prior to Effective Date of this Chapter.* Nothing in this Chapter shall be deemed to require a change in the plans, construction, or designated use of any building on which actual construction was lawfully begun prior to the effective date of this Chapter, or an amendment thereto, and upon which actual building construction has been diligently conducted.
- (5) *Acquisition of Nonconformities.* The City may acquire, through purchase or condemnation, private nonconforming lots, buildings, structures, and uses. The City Council may take actions related to acquisition in the manner provided for by law.

- 
- (6) If a nonconformity existing prior to the effective date on this Chapter becomes conforming because of the adoption of this Chapter, or any subsequent amendment, then it shall no longer have a nonconforming status. A condition that was not a nonconformity prior to the effective date of this Chapter does not achieve any nonconforming status under this Chapter by repeal of the previous Chapter.
- (b) *Replacement with a conforming use.* If a nonconforming use of a building or structure, or land is replaced with a permitted use for the district, all buildings or structures, land, and site design shall thereafter conform to the standard, regulations, and requirements of this Chapter for the district in which such buildings or structures, land, and site is located. The nonconforming use shall not thereafter be resumed.
- (c) *Nonconforming Lot of Record.*
- (1) *Use Permitted.*
- a. A nonconforming lot may be used for any use permitted in the zoning district, subject to any approvals required by this Chapter, provided that all placement, height and other applicable regulations related to the building are met, except as noted below in Subsection b.
- b. A side yard requirement for a building or structure on a nonconforming lot may be reduced by the same percentage the area of the lot bears to the zoning district requirements. For example, a lot that is twenty (20) percent less than the minimum lot area may reduce the required side yard by twenty (20) percent, provided that no side yard shall be less than five (5) feet.
- (2) *Contiguous Nonconforming Lots in Common Ownership.*
- a. Any two (2) or more nonconforming lots of record or combination of lots and portions of lots of record, existing prior to the effective date of this Chapter, or an amendment thereto, shall be considered to be an undivided parcel for the purposes of this Chapter if they:
1. Are in common ownership; and
  2. Have continuous frontage; and
  3. Individually do not meet the lot width or lot area requirements of this Chapter.
- b. Parcels meeting these requirements shall be combined into a lot or lots complying as nearly as possible with the lot width and lot size requirements of this Chapter. No portion of that parcel shall be used or divided in a manner that further diminishes compliance with lot width and area requirements of this Chapter.
- (d) *Nonconforming Buildings or Structures.*
- (1) *Continuation.* Where a lawful structure exists at the effective date of adoption or amendment of this Chapter, but could not be built under the terms of this Chapter by reason of restrictions on area, lot coverage, height, yards, or other characteristics of the

---

structure or its location on the lot, such structure may be continued so long as it remains otherwise lawful

- (2) *Extensions or Expansion.* No such building or structure may be enlarged or altered in a way that increases its nonconformity without the granting of a variance from the Zoning Board of Appeals (see Section 28-238 of this Chapter). Such buildings or structures may be enlarged or altered in a way that does not increase its nonconformity.
- (3) *Expansion of a nonconforming residential building.* A nonconforming residential building may be expanded into a required yard in a manner that does not comply with the setback standards with approval from the zoning administrator or chief building official, provided it is also in accordance with the following standards:
  - a. The expansion does not extend closer to the lot line than any existing, nonconforming part of the structure;
  - b. The expansion does not create a new nonconformity on the lot or an adjacent lot.
  - c. The addition may be constructed up to the front or rear block building line (see Section 28-5 of this Chapter for the definition of "block building line, front or rear") when more than fifty (50) percent of the principal structures on one (1) side of the street in any one (1) block do not meet the required front or rear yard setbacks.
  - d. The addition may be constructed into the required side yard providing it remains in compliance with Section 28-81, side yard exceptions in R districts.
  - e. The addition retains compliance with all other setback, lot coverage, and height requirements;
  - f. The addition will meet all minimum building code requirements;
  - g. The resultant addition, in terms of dimensions and design, would be compatible with the established character of the neighborhood;
  - h. The design of the addition must be compatible with the existing structure and not detract from the appearance of the site;
  - i. The expansion of a residential building with a nonconforming yard, not meeting the requirements above, is prohibited unless a variance is granted by the Zoning Board of Appeals (see Section 28-238 of this Chapter).
- (4) *Alteration or Modification.* Should such building or structure be altered or modified so as to eliminate, remove or lessen any or all of its nonconforming characteristics, then such nonconforming characteristics cannot be later reestablished or increased.
- (5) *Moving a nonconforming structure.* Should such building or structure be moved for any reason for any distance, it must thereafter conform to the regulations for the district in which it is located after it is moved. This does not affect the right to replace, restore, or reconstruct an accessory structure provided it meets all of the other requirements of this Chapter [see Subsection 28-120(2)(b)].

---

(e) *Nonconforming Use of Buildings or Structures.*

- (1) *Extension within a Building.* Any nonconforming use may be extended throughout any parts of a building which were manifestly arranged or designed for that use at the time of adoption or amendment of this Chapter and would have been permitted by right, but the use shall not be extended to occupy any land outside the building.
- (2) *Reduction in Nonconforming Use.* If any part of a nonconforming use is moved or reduced in size by action of the owner, the part of the nonconforming use that is moved or reduced in size shall be considered to be abandoned and any subsequent use shall conform to the requirements of this Chapter.
- (3) *Abandonment.*
  - a. If a nonconforming use of a building or structure is abandoned or discontinued for any reason for a period greater than twelve (12) consecutive months, any subsequent use of the building or structure shall conform to the requirements of this Chapter.
  - b. A nonconforming use of a building or structure shall be determined to be abandoned or discontinued if the City is in receipt of a written declaration by the property owner that the nonconforming use of the building or structure will not be continued, or if two (2) or more of the following conditions exist that demonstrate intent on the part of the property owner to abandon or discontinue the nonconforming use of the building or structure:
    1. Foreclosure;
    2. One (1) or more utility meters, such as water, gas, or electricity to the property, have been removed, disconnected, or shut-off;
    3. The property, buildings and/or grounds are unsafe or unsanitary, as described in Chapter 14 Housing or Chapter 17 Nuisances;
    4. Cessation of the nonconforming use or business operations during the abandonment or discontinuance period;
    5. Removal of signs or other indications of the existence of the nonconforming use;
    6. Removal of equipment or fixtures necessary for the operation of the nonconforming use;
    7. Failure to maintain current licenses, certificates, permits, registrations or other appropriate documentation; or
    8. Other actions which constitute an intention by the property owner or lessee to abandon or discontinue the nonconforming use.

- 
- c. *Exceptions.*
1. Abandonment will not be considered only when a property owner can provide documentation demonstrating a good faith effort to actively sell or lease the premises for a use less intense by function or operation than the previous nonconforming use. This exception shall not apply to discontinued nonconforming uses except as otherwise specifically set forth in this section.
- (4) *Change to Other Nonconforming Use of Buildings or Structures.* Prior to a determination of abandonment or discontinuance, a nonconforming use shall only be changed to another nonconforming use provided the Zoning Board of Appeals makes all of the following determinations.
- a. The proposed use is equally compatible, or more compatible, with the surrounding neighborhood, and that the use is equal to or more conforming to the uses allowed in the zoning district than the previous nonconforming use.
  - b. The proposed nonconforming use is not enlarged or increased, nor extended to occupy a greater area of land than the previous nonconforming use, except as may otherwise be permitted by the Zoning Board of Appeals.
  - c. That buildings and area encompassing the expansion of the nonconforming use complies with all parking, landscaping, or other site development regulations applicable to the area affected by the proposed enlargement, increase or extension of use area as required by this Chapter.
- (f) *Nonconforming Uses of Land.* The lawful use of any land not involving a building or structure, existing and lawful on the effective date of this Chapter or amendment thereto, may be continued even though such use does not conform to the provisions of this Chapter or amendments, subject to the following provisions:
- (1) *Enlargement or Increase.*
- a. No nonconforming use of land not involving a building or structure shall be enlarged or increased, nor extended to occupy a greater area of land than was occupied when the use became nonconforming, except as may be permitted by the Zoning of Board Appeals.
  - b. In determining if the proposed enlargement, increase, or greater area shall be permitted, the Zoning of Board Appeals shall find that if approved, the use shall:
    1. The use has not lost its nonconforming status due to abandonment;
    2. Not have a substantial detrimental effect on the use and enjoyment of adjacent uses or lots;
    3. Comply with all parking, sign, or other applicable regulations for accessory uses for the area affected by the proposed enlargement, increase, or greater area;
    4. Not occupy an area larger than twenty-five (25) percent of the original nonconforming area.

- 
- c. The Zoning Board of Appeals may impose reasonable conditions that are necessary to ensure that the proposed enlargement, increase, or greater area shall not prove detrimental to adjacent properties, the neighborhood, or the community.
- (2) *Relocations.* No such nonconforming use can be moved to any other portion of the lot occupied by such use on the effective date of this Chapter, or amendments thereto.
- (3) *Abandonment.*
- a. If a nonconforming use of land not involving a building or structure is abandoned or discontinued for any reason for a period greater than twelve (12) consecutive months, any subsequent use of the land not involving a building or structure shall conform to the requirements of this Chapter.
  - b. A nonconforming use of the land not involving a building or structure shall be determined to be abandoned or discontinued if the City is in receipt of a written declaration by the property owner that the nonconforming use of the land not involving a building or structure will not be continued, or if two (2) or more of the following conditions exist that demonstrate intent on the part of the property owner to abandon or discontinue the nonconforming use of the land not involving a building or structure:
    - 1. Foreclosure;
    - 2. One (1) or more utility meters, such as water, gas, or electricity to the property, have been removed, disconnected, or shut-off;
    - 3. The property and/or grounds are unsafe or unsanitary, as described in Chapter 14 Housing or Chapter 17 Nuisances;
    - 4. Cessation of the nonconforming use or business operations during the abandonment or discontinuance period;
    - 5. Removal of signs or other indications of the existence of the nonconforming use;
    - 6. Removal of equipment for the operation of the nonconforming use;
    - 7. Failure to maintain current licenses, certificates, permits, registrations or other appropriate documentation; or
    - 8. Other actions which constitute an intention by the property owner or lessee to abandon or discontinue the nonconforming use.
  - c. *Exceptions.*
    - 1. Abandonment will not be considered only when a property owner can provide documentation demonstrating a good faith effort to actively sell or lease the premises for a use less intense by function or operation than the previous nonconforming use. This exception shall not apply to discontinued nonconforming uses except as otherwise specifically set forth in this section.

---

(4) *Change to Other Nonconforming Use of Land.* Prior to a determination of abandonment or discontinuance, a nonconforming use shall only be changed to another nonconforming use provided the Zoning Board of Appeals makes all of the following determinations.

- a. The proposed use is equally compatible, or more compatible, with the surrounding neighborhood, and that the use is equal to or more conforming to the uses allowed in the zoning district than the previous nonconforming use.
- b. The proposed nonconforming use is not enlarged or increased, nor extended to occupy a greater area of land than the previous nonconforming use, except as may otherwise be permitted by the Zoning Board of Appeals.
- c. That buildings and area encompassing the expansion of the nonconforming use complies with all parking, landscaping, or other site development regulations applicable to the area affected by the proposed enlargement, increase or extension of use area as required by this Chapter.

(g) *Repairs, Replacement, Alterations, or Improvements.*

(1) *Nonconforming Commercial or Industrial uses, structures or buildings.*

- a. Should the total costs of repairs, replacement, alterations, or improvements to a nonconforming use, building or structure, for any reason, be less than or equal to seventy-four (74) percent of the assessed value of the building or structure, it may be repaired, replaced, altered, or improved in its previously nonconforming location, provided that:
  1. The dimensional characteristics of the building as it existed at the time of passage or amendment of this Chapter is not increased. This does not allow for the separation or expansion of utility systems; and
  2. The building, structure or use has not lost its nonconforming status due to abandonment.
- b. Should the total costs of repairs, replacement, alterations, or improvements to a nonconforming use, building or structure, for any reason, be greater than or equal to seventy-five (75) percent of the assessed value of the building or structure,, it shall be repaired, replaced, altered, or improved only in conformance with the provisions of this Chapter.

(2) *Nonconforming one-family uses, structures or buildings.* A nonconforming one-family detached dwelling and its accessory structures in any zoning districts may be continued, replaced, or repaired if damaged by fire, vandalism, flood or other force of nature, if approved by the zoning administrator or chief building official. Such approval requires a finding that the resulting building footprint and height will be the same size or smaller than that of the building or structure before such change. Replacement of a nonconforming one-family building or structure must commence within one (1) year of the date of damage and work must be diligently pursued toward completion. Failure to complete replacement or diligently work toward completion, or use of the building for

---

a conforming non-residential use for any period of time, will result in the loss of nonconforming status unless good cause for the delay or temporary change in use is accepted by the zoning administrator or building official.

- (3) *Assessed Value.* For the purposes of enforcing the regulations contained in this section, the value (see the definition in Section 28-5 of this Chapter) of the structure will be determined by the most recent valuation of the structure for the purposes of taxation.
- (4) *Ordinary Repair/Maintenance.* Nothing in this section prevents ordinary repair/maintenance, or the strengthening or restoring to a safe condition of any building or structure, or part thereof, deemed to be unsafe by an official charged with protecting the public safety, upon order of such official.

(h) *Nonconforming Site Design.*

- (1) *Purpose.* This Section permits reviews of applications for improvements and minor modifications to a nonconforming lot, building, structure or use that does not require a site to meet all of the site improvement regulations, requirements, and standards of this Chapter. Where appropriate, the intent is to allow gradual compliance with site-related requirements for sites that pre-date requirements for landscaping, surface treatment for parking areas or drives, curbing and other non-safety site-related items provided in Article IV.
- (2) *Improvements or Modifications.* Improvements or modifications to nonconforming site design may be administratively approved through the site plan review process without a complete upgrade of all site elements under the following conditions:
  - a. The applicant provides reasonable site improvements to the site in relation to the scale and construction cost of the building improvements or expansion;
  - b. The applicant addresses any safety-related site issues for the site;
  - c. The improvements or minor expansion do not increase the nonconforming site elements;
  - d. The applicant upgrades the site landscaping consistent with Section 28-105, to the degree deemed appropriate by the zoning administrator or chief building official; and
  - e. Driveways that do not conform to the access management requirements of this Chapter are eliminated, provided that minimum reasonable access is maintained.
- (3) *Compliance Required.* Site design standards and requirements shall be brought into full compliance with this Chapter, except as may otherwise be permitted by the Zoning Board of Appeals, if any of the following occur:
  - a. Change from nonconforming use to a permitted use.
    - 1. See Section 28-130(b).

- 
- b. *Parking Lot/Area.* Any expansion, reduction, resurfacing, replacement, or reconstruction of greater than or equal to twenty-five (25) percent of the existing designated off-street parking area shall require all new, existing, and/or remaining off-street parking area(s), maneuvering lanes, and ingress and egress meet the standards and requirements of Article IV. This does not include general maintenance; i.e. sealcoating.
  - c. Modification, alteration, replacement, or expansion of existing landscape areas (trees, shrubs, ground cover, or similar materials). This shall also include all proposed landscape installations.
  - d. Replacement of nonconforming exterior light fixtures, light poles, or combination thereof shall meet the requirement of Section 28-109.
- (4) Nothing in this Section shall be construed to require the removal of vegetation preserved as part of the original construction of the landscaped area.
  - (5) In all instances, required screening walls for waste receptacles, fencing of outdoor storage or screening from adjacent residential uses shall be provided.
  - (6) The City may require a performance guarantee under the provisions of Section 28-165 to insure that all improvements required in this Section are made in accordance with the approved plan.
- (i) *Nonconforming signs.*
    - (2) The goal is to eliminate nonconforming signs, except as otherwise specifically set forth in this section. Any lawfully erected sign, which is made unlawful by this chapter, may continue exactly as the sign existed at the time when the sign became unlawful under the provisions of this Chapter. However, following ninety (90) days after the discontinuance of the previously approved use associated with the sign, sign panels shall be replaced with blank panels and any interior lighting shall be disconnected. Twelve (12) months after discontinuance, the sign structure shall be removed.
    - (3) No nonconforming sign shall:
      - a. Be changed to another nonconforming sign without a variance;
      - b. Be structurally altered so as to change the shape, size, type or design of the sign;
      - c. Be re-established after the activity, business or use to which it relates has been discontinued for ninety (90) days or longer.
    - (4) Ordinary repair/maintenance.
      - a. The provisions of this Chapter shall not apply to the ordinary repair/maintenance of existing signs or changing of sign panels or to the altering of a sign specifically designed for periodic change of message without change in sign structure, such as a bulletin board or similar type of sign. The replacement of a manual changeable message sign with a digital message sign is specifically excluded from this provision.

- 
- b. Repairs may be done to a nonconforming sign to an extent not exceeding fifty (50%) percent of the value of the sign, provided that:
    - i. The dimensional characteristics of the sign as it existed at the time of passage or amendment of this Chapter is not increased; and
    - ii. The sign has not lost its nonconforming status due to vacancy, discontinuance or abandonment.
  - c. In the event that any nonconforming sign requires ordinary repair/maintenance for any reason and in any manner that exceeds fifty (50%) percent of the value of the sign, such repairs shall be permitted only in conformity with the provisions of this Chapter. However, if complying with this Chapter is unfeasible and/or impractical, a property owner may seek a variance from the Zoning Board of Appeals (see Section 28-238 of this Chapter), assuming it can also be demonstrated that the original structure was consistent with the established character of the area.
- (j) Nonconforming medical and adult use marihuana facility uses. Medical and adult use marihuana facilities, including a grower, provisioning center, retailer, safety compliance facility, secure transporter, microbusiness, or any marihuana facility or establishment of any type, other than that of a licensed caregiver operating within the limits of the Michigan Medical Marihuana Act, which may have been established prior to the effective date of this ordinance, but which have not gained a license from both the State of Michigan and the City of Jackson shall not be considered nonconforming uses. In addition, no marihuana facilities may be permitted as a home occupation or accessory use.

#### **ARTICLE IX. SIGN REGULATIONS**

##### **Sec. 28-253. – Signs subject to permit or other approvals**

The signs outlined in the following table are subject to a permit or other approval as indicated. Unless stated otherwise within the article, all other sign types are exempt from the permit requirements. The design requirements and other provisions for such sign are also prescribed. Permit application requirements are found in section 28-254. These signs include the following and are defined in section 28-5.

Table of Sign Standards for Signs Subject to a Permit Unless Otherwise Specified (in this Table)			
	Sign Types, Districts Permitted, Required Approvals	Size Restrictions	Additional Restrictions
(f)	<p><i>Monument (Ground) Signs.</i></p> <p>Permitted in the R-4, R-6, C-1, C-2, C-3, C-4, I-1, and I-2 Districts subject to a sign permit.</p> <p>Permitted in the R-1, R-2, and R-3 Districts subject to conditional use approval (section 28-147)</p>	<p><i>Number.</i> One (1) monument/ground sign per lot in addition to permitted wall, awning, and window signage.</p> <p><i>Total Sign Area.</i> Twenty (20) square feet per sign face in the R-4, and R-6 Districts, forty (40) square feet in the C-1, C-2, and C-3 Districts, and sixty (60) square feet in the C-4, I-1, and I-2 Districts.</p> <p><i>Height.</i> Five (5) feet above grade in the R-1 through R-3, R-4, R-6, C-1, and C-2 Districts, and six (6) feet above grade in the C-4, I-1, and I-2 Districts.</p>	<p>No part of monument sign may be placed within five (5) feet of a front lot line or within five (5) feet of a side lot line. In no case may the sign violate the provisions of section 28-126, visibility at intersections.</p> <p>Sign materials and sign colors must complement the building(s) located on the site and emulate the high quality traditional character of the city.</p>
(m)	<p><i>Projecting LED Wall Signs</i></p> <p>Only permitted in the C-3 District,</p>	<p><i>Number.</i> One (1) projecting LED wall sign per façade as permitted below. Shall not be in combination with wall signs as described in Section 28.253(l).</p>	<p>Shall only have a static message or image that changes if the rate of change between two (2) static messages or images does not exceed more than one (1)</p>

	<p>subject to a sign permit.</p>	<p><i>Total Sign Area.</i> The sign's surface shall not exceed five (5) square feet per side.</p> <p><i>Height.</i> Projecting LED wall signs must be affixed to the front façade of the business and allow a nine (9) foot clearance from the bottom of the sign to the sidewalk. The top of the sign shall not be installed at a height taller than the bottom of the second floor or between the parapet and the windows of a single story structure.</p>	<p>change per five (5) minutes, each change is complete in one (1) second or less, and the maximum daylight sign luminance level does not exceed four thousand (4,000) candelas per meter squared and does not exceed three hundred seventy-five (375) candelas per meter squared at all other times. In addition, any sign permitted to have this changeable copy, must configure to default to a static display in the event of mechanical failure.</p> <p>Any sign projecting greater than fifteen (15) inches into a public right-of-way requires a revocable license (see section 28-166).</p>
--	----------------------------------	--	---

Section 3. Effective Date.

This Ordinance takes effect thirty (30) days from the date of final adoption.

The foregoing Ordinance No. 2023-03 was adopted by the Jackson City Council on the 24<sup>th</sup> day of January, 2023 and a summary published on January 29, 2023.

---

Andrea Muray, City Clerk

---

Daniel Mahoney, Mayor

**ARTICLE I. IN GENERAL**  
**SECTION 28-5. - DEFINITIONS**

December 27, 2022 v3

---

**ARTICLE I. IN GENERAL**

**(REDLINE)**

**Sec. 28-5. – Definitions.**

*Structure* means anything constructed or erected, the use of which requires permanent location on the ground, or attachment to something having a permanent location on the ground, ~~to include, but not be limited to driveways, parking lots, in-ground and above-ground swimming pools, and similar recreational facilities.~~

**(CLEAN)**

**Sec. 28-5. – Definitions.**

*Structure* means anything constructed or erected, the use of which requires permanent location on the ground, or attachment to something having a permanent location on the ground.

DRAFT

**ARTICLE IV. SITE AND BUILDING DESIGN STANDARDS**  
**SECTION 28-100. – OFF-STREET PARKING, LOADING, AND ACCESS DESIGN STANDARDS**

December 27, 2022 v3

**ARTICLE IV. SITE AND BUILDING DESIGN STANDARDS**

**(REDLINE)**

**Sec. 28-100. – Off-street parking, loading, and access design standards.**

(g) *Off-street parking space layout standards, construction and maintenance.*

(1) *Curbs.*

c. *Existing commercial and industrial use.* If the ~~use of~~ property ~~has been~~ is determined to be vacant, abandoned or discontinued for a period of ~~nine (9)~~ twelve (12) consecutive months or more, or, if the damage, repair, alteration or improvement costs to the building or structure meets or exceeds one hundred (100) percent of the taxable value, or any expansion, reduction, resurfacing, replacement, or reconstruction of greater than or equal to twenty-five (25) percent of the existing designated off-street parking area then;

1. *Corner lots:* Curbing shall be required in all addressed and non-addressed front yards and designated side yards.
2. *Interior lots:* Curbing shall be required for all parking areas located in the designated front yard and along public rights-of-way. At the discretion of the zoning administrator (or designee) curbing may be required for parking areas located in the designated side yard and rear yard based on the abutting or adjoining property use or condition.
3. *All lots:* All interior islands and access aisles shall be curbed.

**(CLEAN)**

**Sec. 28-100. – Off-street parking, loading, and access design standards.**

(h) *Off-street parking space layout standards, construction and maintenance.*

(2) *Curbs.*

d. *Existing commercial and industrial use.* If the property is determined to be abandoned or discontinued for a period of twelve (12) consecutive months or more, or, if the damage, repair, alteration or improvement costs to the building or structure meets or exceeds one hundred (100) percent of the taxable value, or any expansion, reduction, resurfacing, replacement, or reconstruction of greater than or equal to twenty-five (25) percent of the existing designated off-street parking area then;

4. *Corner lots:* Curbing shall be required in all addressed and non-addressed front yards and designated side yards.
5. *Interior lots:* Curbing shall be required for all parking areas located in the designated front yard and along public rights-of-way. At the discretion of the zoning administrator (or designee) curbing may be required for parking areas located in the designated side yard and rear yard based on the abutting or adjoining property use or condition.
6. *All lots:* All interior islands and access aisles shall be curbed.

**ARTICLE V. DEVELOPMENT APPROVAL PROCEDURES**  
**SECTION 28-130. – NONCONFORMING LOTS, BUILDINGS, SIGNS, STRUCTURES,**  
**AND USES OF BUILDINGS, STRUCTURES AND LAND.**

December 27, 2022 v3

---

**ARTICLE V. DEVELOPMENT APPROVAL PROCEDURES**

**Sec. 28-130. - Nonconforming lots, buildings, signs, structures, and uses of buildings, structures and land.**

(a) *Purpose and Intent.*

- (1) *Nonconformities Permitted.* It is recognized that there exists within zoning districts, established by this Chapter, certain lots, buildings, structures, site improvements, and uses which were lawful before this Chapter was passed or amended, which would be prohibited, regulated, or restricted under the terms of this Chapter. It is the intent of this Chapter to permit these nonconforming lots, buildings, structures, and uses to continue until they are altered, abandoned, removed, or brought into conformance, but not to encourage their continued use or survival.
- (2) *Site Improvements.* Encourage gradual upgrading to a more conforming status of site and parking lot landscaping, parking (quantity and surface materials), paving/curbing, signage or other features of a site which were developed in compliance with the standards at the time of their construction, but which do not meet the current site plan or other standards of this Chapter and its amendments.
- (3) *No Expansion of Nonconformities.* Nonconforming lots, buildings, structures, and uses are hereby declared to be incompatible with the zoning districts in which they are located. It is the intent of this Chapter that these nonconformities shall not be enlarged upon, expanded, or extended, nor be used as grounds for adding other buildings, structures or uses prohibited elsewhere in the zoning district, except as may be provided for in this Chapter.
- (4) *Construction Prior to Effective Date of this Chapter.* Nothing in this Chapter shall be deemed to require a change in the plans, construction, or designated use of any building on which actual construction was lawfully begun prior to the effective date of this Chapter, or an amendment thereto, and upon which actual building construction has been diligently conducted.
- (5) *Acquisition of Nonconformities.* The City may acquire, through purchase or condemnation, private nonconforming lots, buildings, structures, and uses. The City Council may take actions related to acquisition in the manner provided for by law.
- (6) If a nonconformity existing prior to the effective date on this Chapter becomes conforming because of the adoption of this Chapter, or any subsequent amendment, then it shall no longer have a nonconforming status. A condition that was not a nonconformity prior to the effective date of this Chapter does not achieve any nonconforming status under this Chapter by repeal of the previous Chapter.

- (b) *Replacement with a conforming use.* If a nonconforming use of a building or structure, or land is replaced with a permitted use for the district, all buildings or structures, land, and site design shall thereafter conform to the standard, regulations, and requirements of this Chapter for the district in which such buildings or structures, land, and site is located. The nonconforming use shall not thereafter be resumed.

(c) *Nonconforming Lot of Record.*

(1) *Use Permitted.*

- a. A nonconforming lot may be used for any use permitted in the zoning district, subject to any approvals required by this Chapter, provided that all placement, height and other applicable regulations related to the building are met, except as noted below in Subsection b.

- 
- b. A side yard requirement for a building or structure on a nonconforming lot may be reduced by the same percentage the area of the lot bears to the zoning district requirements. For example, a lot that is twenty (20) percent less than the minimum lot area may reduce the required side yard by twenty (20) percent, provided that no side yard shall be less than five (5) feet.
- (2) *Contiguous Nonconforming Lots in Common Ownership.*
- a. Any two (2) or more nonconforming lots of record or combination of lots and portions of lots of record, existing prior to the effective date of this Chapter, or an amendment thereto, shall be considered to be an undivided parcel for the purposes of this Chapter if they:
1. Are in common ownership; and
  2. Have continuous frontage; and
  3. Individually do not meet the lot width or lot area requirements of this Chapter.
- b. Parcels meeting these requirements shall be combined into a lot or lots complying as nearly as possible with the lot width and lot size requirements of this Chapter. No portion of that parcel shall be used or divided in a manner that further diminishes compliance with lot width and area requirements of this Chapter.
- (d) *Nonconforming Buildings or Structures.*
- (1) *Continuation.* Where a lawful structure exists at the effective date of adoption or amendment of this Chapter, but could not be built under the terms of this Chapter by reason of restrictions on area, lot coverage, height, yards, or other characteristics of the structure or its location on the lot, such structure may be continued so long as it remains otherwise lawful
- (2) *Extensions or Expansion.* No such building or structure may be enlarged or altered in a way that increases its nonconformity without the granting of a variance from the Zoning Board of Appeals (see Section 28-238 of this Chapter). Such buildings or structures may be enlarged or altered in a way that does not increase its nonconformity.
- (3) *Expansion of a nonconforming residential building.* A nonconforming residential building may be expanded into a required yard in a manner that does not comply with the setback standards with approval from the zoning administrator or chief building official, provided it is also in accordance with the following standards:
- a. The expansion does not extend closer to the lot line than any existing, nonconforming part of the structure;
  - b. The expansion does not create a new nonconformity on the lot or an adjacent lot.
  - c. The addition may be constructed up to the front or rear block building line (see Section 28-5 of this Chapter for the definition of "block building line, front or rear") when more than fifty (50) percent of the principal structures on one (1) side of the street in any one (1) block do not meet the required front or rear yard setbacks.
  - d. The addition may be constructed into the required side yard providing it remains in compliance with Section 28-81, side yard exceptions in R districts.
  - e. The addition retains compliance with all other setback, lot coverage, and height requirements;
  - f. The addition will meet all minimum building code requirements;
  - g. The resultant addition, in terms of dimensions and design, would be compatible with the established character of the neighborhood;
  - h. The design of the addition must be compatible with the existing structure and not detract from the appearance of the site;
-

- 
- i. The expansion of a residential building with a nonconforming yard, not meeting the requirements above, is prohibited unless a variance is granted by the Zoning Board of Appeals (see Section 28-238 of this Chapter).
  - (4) *Alteration or Modification.* Should such building or structure be altered or modified so as to eliminate, remove or lessen any or all of its nonconforming characteristics, then such nonconforming characteristics cannot be later reestablished or increased.
  - (5) *Moving a nonconforming structure.* Should such building or structure be moved for any reason for any distance, it must thereafter conform to the regulations for the district in which it is located after it is moved. This does not affect the right to replace, restore, or reconstruct an accessory structure provided it meets all of the other requirements of this Chapter [see Subsection 28-120(2)(b)].
- (e) *Nonconforming Use of Buildings or Structures.*
- (1) *Extension within a Building.* Any nonconforming use may be extended throughout any parts of a building which were manifestly arranged or designed for that use at the time of adoption or amendment of this Chapter and would have been permitted by right, but the use shall not be extended to occupy any land outside the building.
  - (2) *Reduction in Nonconforming Use.* If any part of a nonconforming use is moved or reduced in size by action of the owner, the part of the nonconforming use that is moved or reduced in size shall be considered to be abandoned and any subsequent use shall conform to the requirements of this Chapter.
  - (3) *Abandonment.*
    - a. If a nonconforming use of a building or structure is abandoned or discontinued for any reason for a period greater than twelve (12) consecutive months, any subsequent use of the building or structure shall conform to the requirements of this Chapter.
    - b. A nonconforming use of a building or structure shall be determined to be abandoned or discontinued if the City is in receipt of a written declaration by the property owner that the nonconforming use of the building or structure will not be continued, or if two (2) or more of the following conditions exist that demonstrate intent on the part of the property owner to abandon or discontinue the nonconforming use of the building or structure:
      - 1. Foreclosure;
      - 2. One (1) or more utility meters, such as water, gas, or electricity to the property, have been removed, disconnected, or shut-off;
      - 3. The property, buildings and/or grounds are unsafe or unsanitary, as described in Chapter 14 Housing or Chapter 17 Nuisances;
      - 4. Cessation of the nonconforming use or business operations during the abandonment or discontinuance period;
      - 5. Removal of signs or other indications of the existence of the nonconforming use;
      - 6. Removal of equipment or fixtures necessary for the operation of the nonconforming use;
      - 7. Failure to maintain current licenses, certificates, permits, registrations or other appropriate documentation; or
      - 8. Other actions which constitute an intention by the property owner or lessee to abandon or discontinue the nonconforming use.
    - c. *Exceptions.*
      - 1. Abandonment will not be considered only when a property owner can provide documentation demonstrating a good faith effort to actively sell or lease the premises for a use less intense
-

by function or operation than the previous nonconforming use. This exception shall not apply to discontinued nonconforming uses except as otherwise specifically set forth in this section.

- (4) *Change to Other Nonconforming Use of Buildings or Structures.* Prior to a determination of abandonment or discontinuance, a nonconforming use shall only be changed to another nonconforming use provided the Zoning Board of Appeals makes all of the following determinations.
- a. The proposed use is equally compatible, or more compatible, with the surrounding neighborhood, and that the use is equal to or more conforming to the uses allowed in the zoning district than the previous nonconforming use.
  - b. The proposed nonconforming use is not enlarged or increased, nor extended to occupy a greater area of land than the previous nonconforming use, except as may otherwise be permitted by the Zoning Board of Appeals.
  - c. That buildings and area encompassing the expansion of the nonconforming use complies with all parking, landscaping, or other site development regulations applicable to the area affected by the proposed enlargement, increase or extension of use area as required by this Chapter.
- (f) *Nonconforming Uses of Land.* The lawful use of any land not involving a building or structure, existing and lawful on the effective date of this Chapter or amendment thereto, may be continued even though such use does not conform to the provisions of this Chapter or amendments, subject to the following provisions:
- (1) *Enlargement or Increase.*
    - a. No nonconforming use of land not involving a building or structure shall be enlarged or increased, nor extended to occupy a greater area of land than was occupied when the use became nonconforming, except as may be permitted by the Zoning of Board Appeals.
    - b. In determining if the proposed enlargement, increase, or greater area shall be permitted, the Zoning of Board Appeals shall find that if approved, the use shall:
      1. The use has not lost its nonconforming status due to abandonment;
      2. Not have a substantial detrimental effect on the use and enjoyment of adjacent uses or lots;
      3. Comply with all parking, sign, or other applicable regulations for accessory uses for the area affected by the proposed enlargement, increase, or greater area;
      4. Not occupy an area larger than twenty-five (25) percent of the original nonconforming area.
    - c. The Zoning Board of Appeals may impose reasonable conditions that are necessary to ensure that the proposed enlargement, increase, or greater area shall not prove detrimental to adjacent properties, the neighborhood, or the community.
  - (2) *Relocations.* No such nonconforming use can be moved to any other portion of the lot occupied by such use on the effective date of this Chapter, or amendments thereto.
  - (3) *Abandonment.*
    - a. If a nonconforming use of land not involving a building or structure is abandoned or discontinued for any reason for a period greater than twelve (12) consecutive months, any subsequent use of the land not involving a building or structure shall conform to the requirements of this Chapter.
    - b. A nonconforming use of the land not involving a building or structure shall be determined to be abandoned or discontinued if the City is in receipt of a written declaration by the property owner that the nonconforming use of the land not involving a building or structure will not be continued, or if two (2) or more of the following conditions exist that demonstrate intent on the part of the property owner to abandon or discontinue the nonconforming use of the land not involving a building or structure:
      1. Foreclosure;

2. One (1) or more utility meters, such as water, gas, or electricity to the property, have been removed, disconnected, or shut-off;
3. The property and/or grounds are unsafe or unsanitary, as described in Chapter 14 Housing or Chapter 17 Nuisances;
4. Cessation of the nonconforming use or business operations during the abandonment or discontinuance period;
5. Removal of signs or other indications of the existence of the nonconforming use;
6. Removal of equipment for the operation of the nonconforming use;
7. Failure to maintain current licenses, certificates, permits, registrations or other appropriate documentation; or
8. Other actions which constitute an intention by the property owner or lessee to abandon or discontinue the nonconforming use.

*c. Exceptions.*

1. Abandonment will not be considered only when a property owner can provide documentation demonstrating a good faith effort to actively sell or lease the premises for a use less intense by function or operation than the previous nonconforming use. This exception shall not apply to discontinued nonconforming uses except as otherwise specifically set forth in this section.

*(4) Change to Other Nonconforming Use of Land.* Prior to a determination of abandonment or discontinuance, a nonconforming use shall only be changed to another nonconforming use provided the Zoning Board of Appeals makes all of the following determinations.

- a. The proposed use is equally compatible, or more compatible, with the surrounding neighborhood, and that the use is equal to or more conforming to the uses allowed in the zoning district than the previous nonconforming use.
- b. The proposed nonconforming use is not enlarged or increased, nor extended to occupy a greater area of land than the previous nonconforming use, except as may otherwise be permitted by the Zoning Board of Appeals.
- c. That buildings and area encompassing the expansion of the nonconforming use complies with all parking, landscaping, or other site development regulations applicable to the area affected by the proposed enlargement, increase or extension of use area as required by this Chapter.

*(g) Repairs, Replacement, Alterations, or Improvements.*

*(1) Nonconforming Commercial or Industrial uses, structures or buildings.*

- a. Should the total costs of repairs, replacement, alterations, or improvements to a nonconforming use, building or structure, for any reason, be less than or equal to seventy-four (74) percent of the assessed value of the building or structure, it may be repaired, replaced, altered, or improved in its previously nonconforming location, provided that:
  1. The dimensional characteristics of the building as it existed at the time of passage or amendment of this Chapter is not increased. This does not allow for the separation or expansion of utility systems; and
  2. The building, structure or use has not lost its nonconforming status due to abandonment.
- b. Should the total costs of repairs, replacement, alterations, or improvements to a nonconforming use, building or structure, for any reason, be greater than or equal to seventy-five (75) percent of the assessed value of the building or structure,, it shall be repaired, replaced, altered, or improved only in conformance with the provisions of this Chapter.

- 
- (2) *Nonconforming one-family uses, structures or buildings.* A nonconforming one-family detached dwelling and its accessory structures in any zoning districts may be continued, replaced, or repaired if damaged by fire, vandalism, flood or other force of nature, if approved by the zoning administrator or chief building official. Such approval requires a finding that the resulting building footprint and height will be the same size or smaller than that of the building or structure before such change. Replacement of a nonconforming one-family building or structure must commence within one (1) year of the date of damage and work must be diligently pursued toward completion. Failure to complete replacement or diligently work toward completion, or use of the building for a conforming non-residential use for any period of time, will result in the loss of nonconforming status unless good cause for the delay or temporary change in use is accepted by the zoning administrator or building official.
- (3) *Assessed Value.* For the purposes of enforcing the regulations contained in this section, the value (see the definition in Section 28-5 of this Chapter) of the structure will be determined by the most recent valuation of the structure for the purposes of taxation.
- (4) *Ordinary Repair/Maintenance.* Nothing in this section prevents ordinary repair/maintenance, or the strengthening or restoring to a safe condition of any building or structure, or part thereof, deemed to be unsafe by an official charged with protecting the public safety, upon order of such official.
- (h) *Nonconforming Site Design.*
- (1) *Purpose.* This Section permits reviews of applications for improvements and minor modifications to a nonconforming lot, building, structure or use that does not require a site to meet all of the site improvement regulations, requirements, and standards of this Chapter. Where appropriate, the intent is to allow gradual compliance with site-related requirements for sites that pre-date requirements for landscaping, surface treatment for parking areas or drives, curbing and other non-safety site-related items provided in Article IV.
- (2) *Improvements or Modifications.* Improvements or modifications to nonconforming site design may be administratively approved through the site plan review process without a complete upgrade of all site elements under the following conditions:
- a. The applicant provides reasonable site improvements to the site in relation to the scale and construction cost of the building improvements or expansion;
  - b. The applicant addresses any safety-related site issues for the site;
  - c. The improvements or minor expansion do not increase the nonconforming site elements;
  - d. The applicant upgrades the site landscaping consistent with Section 28-105, to the degree deemed appropriate by the zoning administrator or chief building official; and
  - e. Driveways that do not conform to the access management requirements of this Chapter are eliminated, provided that minimum reasonable access is maintained.
- (3) *Compliance Required.* Site design standards and requirements shall be brought into full compliance with this Chapter, except as may otherwise be permitted by the Zoning Board of Appeals, if any of the following occur:
- a. Change from nonconforming use to a permitted use.
    1. See Section 28-130(b).
  - b. *Parking Lot/Area.* Any expansion, reduction, resurfacing, replacement, or reconstruction of greater than or equal to twenty-five (25) percent of the existing designated off-street parking area shall require all new, existing, and/or remaining off-street parking area(s), maneuvering lanes, and ingress and egress meet the standards and requirements of Article IV. This does not include general maintenance; i.e. sealcoating.

- 
- c. Modification, alteration, replacement, or expansion of existing landscape areas (trees, shrubs, ground cover, or similar materials). This shall also include all proposed landscape installations.
  - d. Replacement of nonconforming exterior light fixtures, light poles, or combination thereof shall meet the requirement of Section 28-109.
- (4) Nothing in this Section shall be construed to require the removal of vegetation preserved as part of the original construction of the landscaped area.
- (5) In all instances, required screening walls for waste receptacles, fencing of outdoor storage or screening from adjacent residential uses shall be provided.
- (6) The City may require a performance guarantee under the provisions of Section 28-165 to insure that all improvements required in this Section are made in accordance with the approved plan.
- (i) *Nonconforming signs.*
- (3) The goal is to eliminate nonconforming signs, except as otherwise specifically set forth in this section. Any lawfully erected sign, which is made unlawful by this chapter, may continue exactly as the sign existed at the time when the sign became unlawful under the provisions of this Chapter. However, following ninety (90) days after the discontinuance of the previously approved use associated with the sign, sign panels shall be replaced with blank panels and any interior lighting shall be disconnected. Twelve (12) months after discontinuance, the sign structure shall be removed.
- (4) No nonconforming sign shall:
- a. Be changed to another nonconforming sign without a variance;
  - b. Be structurally altered so as to change the shape, size, type or design of the sign;
  - c. Be re-established after the activity, business or use to which it relates has been discontinued for ninety (90) days or longer.
- (5) Ordinary repair/maintenance.
- a. The provisions of this Chapter shall not apply to the ordinary repair/maintenance of existing signs or changing of sign panels or to the altering of a sign specifically designed for periodic change of message without change in sign structure, such as a bulletin board or similar type of sign. The replacement of a manual changeable message sign with a digital message sign is specifically excluded from this provision.
  - b. Repairs may be done to a nonconforming sign to an extent not exceeding fifty (50%) percent of the value of the sign, provided that:
    - i. The dimensional characteristics of the sign as it existed at the time of passage or amendment of this Chapter is not increased; and
    - ii. The sign has not lost its nonconforming status due to vacancy, discontinuance or abandonment.
  - c. In the event that any nonconforming sign requires ordinary repair/maintenance for any reason and in any manner that exceeds fifty (50%) percent of the value of the sign, such repairs shall be permitted only in conformity with the provisions of this Chapter. However, if complying with this Chapter is unfeasible and/or impractical, a property owner may seek a variance from the Zoning Board of Appeals (see Section 28-238 of this Chapter), assuming it can also be demonstrated that the original structure was consistent with the established character of the area.
- (j) Nonconforming medical and adult use marijuana facility uses. Medical and adult use marijuana facilities, including a grower, provisioning center, retailer, safety compliance facility, secure transporter, microbusiness, or any marijuana facility or establishment of any type, other than that of a licensed caregiver operating within the limits of the Michigan Medical Marijuana Act, which may have been
-

established prior to the effective date of this ordinance, but which have not gained a license from both the State of Michigan and the City of Jackson shall not be considered nonconforming uses. In addition, no marihuana facilities may be permitted as a home occupation or accessory use.

**ARTICLE IX. SIGN REGULATIONS**  
**SECTION 28-253. – SIGNS SUBJECT TO PERMIT OR OTHER APPROVAL**

December 27, 2022

**ARTICLE IX. SIGN REGULATIONS**

(REDLINE)

**Sec. 28-253. – Signs subject to permit or other approvals**

The signs outlined in the following table are subject to a permit or other approval as indicated. Unless stated otherwise within the article, all other sign types are exempt from the permit requirements. The design requirements and other provisions for such sign are also prescribed. Permit application requirements are found in section 28-254. These signs include the following and are defined in section 28-5.

Table of Sign Standards for Signs Subject to a Permit Unless Otherwise Specified (in this Table)			
	Sign Types, Districts Permitted, Required Approvals	Size Restrictions	Additional Restrictions
(f)	<p><i>Monument (Ground) Signs.</i></p> <p>Permitted in the R-4, R-6, C-1, C-2, C-3, C-4, I-1, and I-2 Districts subject to a sign permit.</p> <p>Permitted in the R-1, R-2, and R-3 Districts subject to conditional use approval (section 28-147)</p>	<p><i>Number.</i> One (1) monument/ground sign per lot in addition to permitted wall, awning, and window signage.</p> <p><i>Total Sign Area.</i> Twenty (20) square feet per sign face in the R-4<sub>z</sub> and R-6 Districts, forty (40) square feet in the C-1, C-2<sub>z</sub> and C-3 Districts, and sixty (60) square feet in the C-4, I-1<sub>z</sub> and I-2 Districts.</p> <p><i>Height.</i> Five (5) feet above grade in the R-1 through R-3, R-4, R-6, C-1, and C-2 Districts<sub>z</sub> and six (6) feet above grade in the C-4, I-1<sub>z</sub> and I-2 Districts.</p>	<p>No part of monument sign may be placed within five (5) feet of a front lot line or within five (5) feet of a side lot line. In no case may the sign violate the provisions of section 28-126, visibility at intersections.</p> <p>Sign materials and sign colors must complement the building(s) located on the site and emulate the high quality traditional character of the city.</p>
(m)	<p><u><i>Projecting LED Wall Signs</i></u></p> <p><u>Only permitted in the C-3 District, subject to a sign permit.</u></p>	<p><u><i>Number.</i> One (1) projecting LED wall sign per façade as permitted below. Shall not be in combination with wall signs as described in Section 28.253(l).</u></p> <p><u><i>Total Sign Area.</i> The sign's surface shall not exceed five (5) square feet per side.</u></p> <p><u><i>Height.</i> Projecting LED wall signs must be affixed to the front façade of the business and allow a nine (9) foot clearance from the bottom of the sign to the sidewalk. The top of the sign shall not be installed at a height taller than the bottom of the second floor or between the parapet and the windows of a single story structure.</u></p>	<p><u>Shall only have a static message or image that changes if the rate of change between two (2) static messages or images does not exceed more than one (1) change per five (5) minutes, each change is complete in one (1) second or less, and the maximum daylight sign luminance level does not exceed four thousand (4,000) candelas per meter squared and does not exceed three hundred seventy-five (375) candelas per meter squared at all other times. In addition, any sign permitted to have this changeable copy, must configure to default to a static display in the event of mechanical failure.</u></p> <p><u>Any sign projecting greater than fifteen (15) inches into a public right-of-way requires a revocable license (see section 28-166).</u></p>

**ARTICLE IX. SIGN REGULATIONS**

(CLEAN)

**Sec. 28-253. – Signs subject to permit or other approvals**

The signs outlined in the following table are subject to a permit or other approval as indicated. Unless stated otherwise within the article, all other sign types are exempt from the permit requirements. The design requirements and other provisions for such sign are also prescribed. Permit application requirements are found in section 28-254. These signs include the following and are defined in section 28-5.

Table of Sign Standards for Signs Subject to a Permit Unless Otherwise Specified (in this Table)			
	Sign Types, Districts Permitted, Required Approvals	Size Restrictions	Additional Restrictions
(f)	<p><i>Monument (Ground) Signs.</i> Permitted in the R-4, R-6, C-1, C-2, C-3, C-4, I-1, and I-2 Districts subject to a sign permit. Permitted in the R-1, R-2, and R-3 Districts subject to conditional use approval (section 28-147)</p>	<p><i>Number.</i> One (1) monument/ground sign per lot in addition to permitted wall, awning, and window signage. <i>Total Sign Area.</i> Twenty (20) square feet per sign face in the R-4, and R-6 Districts, forty (40) square feet in the C-1, C-2, and C-3 Districts, and sixty (60) square feet in the C-4, I-1, and I-2 Districts. <i>Height.</i> Five (5) feet above grade in the R-1 through R-3, R-4, R-6, C-1, and C-2 Districts, and six (6) feet above grade in the C-4, I-1, and I-2 Districts.</p>	<p>No part of monument sign may be placed within five (5) feet of a front lot line or within five (5) feet of a side lot line. In no case may the sign violate the provisions of section 28-126, visibility at intersections. Sign materials and sign colors must complement the building(s) located on the site and emulate the high quality traditional character of the city.</p>
(m)	<p><i>Projecting LED Wall Signs</i> Only permitted in the C-3 District, subject to a sign permit.</p>	<p><i>Number.</i> One (1) projecting LED wall sign per façade as permitted below. Shall not be in combination with wall signs as described in Section 28.253(l). <i>Total Sign Area.</i> The sign's surface shall not exceed five (5) square feet per side. <i>Height.</i> Projecting LED wall signs must be affixed to the front façade of the business and allow a nine (9) foot clearance from the bottom of the sign to the sidewalk. The top of the sign shall not be installed at a height taller than the bottom of the second floor or between the parapet and the windows of a single story structure.</p>	<p>Shall only have a static message or image that changes if the rate of change between two (2) static messages or images does not exceed more than one (1) change per five (5) minutes, each change is complete in one (1) second or less, and the maximum daylight sign luminance level does not exceed four thousand (4,000) candelas per meter squared and does not exceed three hundred seventy-five (375) candelas per meter squared at all other times. In addition, any sign permitted to have this changeable copy, must configure to default to a static display in the event of mechanical failure.  Any sign projecting greater than fifteen (15) inches into a public right-of-way requires a revocable license (see section 28-166).</p>

**MEMO TO:** Mayor and City Councilmembers  
**FROM:** Jonathan Greene, City Manager  
**DATE:** January 24, 2023  
**SUBJECT:** **Recommendation of Approval of First Extension of the 2022 As Needed Materials Testing Services Contract**

---

**Recommendation:**

**Approval of the first extension of the 2022 As Needed Materials Testing Services Contract with Professional Service Industries (PSI), Inc. of Lansing, Michigan in the estimated amount of \$125,000.00, and authorization for the Mayor and City Clerk to execute the appropriate document(s) in accordance with the Purchasing Agent.**

Attached is a report from Jon Dowling, City Engineer, requesting a first extension of the City's 2022 As Needed Materials Services Contract for the 2023 construction season.

I recommend approval of the extension as requested. Your consideration and concurrence is appreciated.

JG

Attachments

T:\Materials Testing\2023\_PSI\_renew\2022 material testing contract 1st ext cover memo.docx

# DEPARTMENTAL REPORT

**MEMO TO:** Jonathan Greene, City Manager  
**FROM:** Jon H. Dowling, P.E., City Engineer  
**DATE:** January 24, 2023

**RECOMMENDATION:** Approval of the first extension of the 2022 As Needed Materials Testing Services Contract with Professional Service Industries (PSI), Inc. of Lansing, Michigan in the estimated amount of \$125,000.00, and authorization for the Mayor and City Clerk to execute the appropriate document(s) in accordance with the Purchasing Agent.

## SUMMARY

On March 8, 2022, City Council approved the award of the 2022 As Needed Materials Testing Services Contract to Professional Service Industries (PSI), Inc. of Lansing Michigan in the amount of \$125,205.00. This contract is subject to two 1-year extensions with a two and a half percent unit price adjustment per year. PSI has submitted the attached letter indicating their desire to renew the contract to provide materials testing services for the 2023 construction season.

## BUDGETARY CONSIDERATIONS

Engineering is requesting that the first extension be approved in the estimated amount of \$125,000.00. This amount will cover the costs for materials testing on the various construction projects that the City will undertake in 2023. This work will be paid for out of various project accounts in the Major Street Fund, Local Street Fund, Sewer Fund and Water Fund.

## HISTORY, BACKGROUND and DISCUSSION

The City of Jackson has annually, for several decades, entered into a professional services contract with an engineering firm to provide testing services to ensure that specifications are met regarding the provision and placement of various materials on the City's construction projects. This is an industry wide standard practice and a requirement for those projects that are funded in part or in whole by state and/or federal grants.

## POSITIONS

In concurrence with the Purchasing Agent, it is Engineering's recommendation that the first extension of the 2022 As Needed Materials Testing Services contract with Professional Service Industries, Inc. of Lansing, Michigan, in the estimated amount of \$125,000.00 be approved, and the Mayor and City Clerk be authorized to execute the appropriate document(s).

---

## ATTACHMENTS



Intertek-PSI  
3120 Sovereign Drive, Suite C  
Lansing, MI 48911

Tel +1 517 394 5700  
Fax +1 517 394 5796  
[intertek.com/building](http://intertek.com/building)

November 18, 2022

Mr. Jon Dowling, P.E.  
City of Jackson  
Department of Engineering  
161 West Michigan Avenue  
Jackson, Michigan 49201

Re: 2022 As Needed Materials Testing Services  
City of Jackson  
Jackson, Michigan

Dear Mr. Dowling:

PSI (Professional Service Industries, Inc.), an Intertek company, is providing as-needed material testing services to the City of Jackson during the 2022 construction seasons. Based on our discussions with the City of Jackson, PSI would be pleased to continue to provide these services in 2023 in accordance with our proposal, dated January 24, 2022, and the current agreement between the City of Jackson and PSI.

PSI appreciates the opportunity to provide our services and we look forward to continuing working with you. If you have any questions or need any additional information, please feel free to call me at 517-394-5700.

Very truly yours,  
**PROFESSIONAL SERVICE INDUSTRIES, INC.**

A handwritten signature in black ink, appearing to read "Joel A. Walter".


Joel A. Walter, P.E.  
Branch Manager

JAW/lmr



## DEPARTMENTAL REPORT

**MEMO TO:** Jonathan Greene, City Manager

**FROM:** Elmer J. Hitt, Director of Police and Fire Services 

**DATE:** January 24, 2023

**RECOMMENDATION:** Accept Bid by Overhead Door Company

---

### SUMMARY

The Jackson Fire Department's Central Station at 518 North Jackson Street has several overhead doors which allow fire apparatus to leave and enter the station coming to and from calls for service. These doors have not been replaced in more than 25 years, and they are falling into disrepair.

### BUDGETARY CONSIDERATIONS

Bids were solicited for the project. A bid from the Overhead Door Company for \$94,145 was the only bid received. Their bid is over the amount budgeted in FY 22/23 by \$19,145. That overage would be offset by the under-budget bid of R.W. Mercer for the Central Station window project.

### HISTORY, BACKGROUND and DISCUSSION

The overhead doors at Station #1 open and close every time a fire apparatus or non-emergency administrative vehicle leave or return to the station. This means the doors are operating multiple times each day. This wear and tear has resulted in frequent repairs to the doors, controllers, and wiring. New doors will also improve the energy efficiency of the building.

### DISCUSSION OF THE ISSUE

The Fire Department would save on energy costs in future years, as well as save on maintenance and repair costs.

### POSITION

I recommend accepting the bid by the Overhead Door Company for the overhead door project at the Central Fire Station.

---

ATTACHMENTS

**MEMO TO:** Mayor and City Councilmembers  
**FROM:** Jonathan Greene, City Manager  
**DATE:** January 24, 2023  
**SUBJECT:** Overhead Doors Project at Jackson Fire Department Station #1

---

**Recommendation:**

Accept bid by the Overhead Door Company

Attached is a memorandum from Director Elmer Hitt regarding the overhead doors at the fire station on N. Jackson St.

I recommend accepting the bid by the Overhead Door Company. Your consideration and concurrence is appreciated.

## CHECKLIST FOR BID SUBMITTAL

- BID BOND – If a bid bond is required, please submit your bid bond with your bid documents
- PROPOSAL SHEETS – Please fill out and have notarized your proposal sheets
- SAMS.GOV - Please register with SAM.GOV to be eligible to work on federally funded projects. Registration is free.

<https://sam.gov/content/entity-registration>

Please provide your sams.gov Unique Identity Number: FAU7MC2DC882  
if you have received it.

# OVERHEAD DOOR CO. OF JACKSON

ODC JACKSON  
444 EAST PROSPECT  
JACKSON, MI 49203  
800-247-7196  
FAX 517-782-2480

ODC JACKSON  
444 EAST PROSPECT  
JACKSON, MICHIGAN 49203  
email : Cameron@ohdbc.com

The Genuine. The Original.



Proposal #: 2-17540

PROPOSAL SUBMITTED TO: City of Jackson			Date 1/9/2023	Attention Purchasing Agent
STREET 161 W. Michigan Ave			Job Name Overehad Door Replacement	
City Jackson	State MI	ZipCode 49201	Job Location 518 N Jackson St. Jackson, MI	
Phone Number 517-788-4020	Fax Number		Job Phone 517-788-4020	

## FURNISH AND INSTALL:

### 2) 11' 8" X 11' 0" Haas model 716 series doors

Doors to include:

- Carbon Black in color
- V-Groove Panel Design
- Sections 3, 4 and 5 to be Full View Glass sections with insulated rails
- Glass to be 1/2" Insulated clear tempered
- Steel front/back with polyurethane insulation (R-16.18)
- 2" Track mounting to steel with low headroom configuration
- 10K torsion springs
- Top Seal

### 5) 12' 2" X 11' 0" Haas model 716 series doors

Doors to include:

- Carbon Black in color
- V-Groove Panel Design
- Sections 3, 4 and 5 to be Full View Glass sections with insulated rails
- Glass to be 1/2" Insulated clear tempered
- Steel front/back with polyurethane insulation (R-16.18)
- 2" Track mounting to steel with low headroom configuration
- 10K torsion springs
- Top Seal
- Jamb Seal

### 3) 12' 2" X 11' 0" Haas model 716 series doors

Doors to include:

- Carbon Black in color
- V-Groove Panel Design
- Section 3 to have (3) 25x12 windows
- Glass to be 1/2" Insulated clear tempered
- Steel front/back with polyurethane insulation (R-16.18)
- 2" Track mounting to steel with low headroom configuration
- 10K torsion springs
- Top Seal

### 3) 12' 2" X 11' 0" Haas model 716 series doors

Doors to include:

- Carbon Black in color
- V-Groove Panel Design
- Section 3 to have (3) 25x12 windows

- Glass to be 1/2" Insulated clear tempered
- Steel front/back with polyurethane insulation (R-16.18)
- 2" Track mounting to steel with high lift
- 10K torsion springs
- Top Seal

13) Overhead Door RSX Commercial Operators

Operators to include:

- Brake and Clutch System
- Chain Rail
- Safety Eyes
- 3-Button Wall Station

Notes:

- Price includes \$7,500.00 electrical allowance as stated in Addendum 1
- Price includes bonding
- Price includes taking down and hauling away the old doors
- Price includes removal of ceiling tiles in order to access the overhead doors and operators
- Price does NOT include re-installing of the ceiling tiles (Please add \$2,200.00 to total for re-installing ceiling tiles)
- Price does NOT include union labor

PRICING VALID FOR 30 DAYS

PAYMENT TERMS: All credit card payments subject to a 4% surcharge. All canceled/change orders will result in a 50% restocking fee.

BY OTHERS: Jambs, spring pads, all wiring to motors and control stations, unless otherwise stated above, are not included. Purchaser agrees that doors shall remain in Seller's possession until paid in full. In the event Purchaser breaches or defaults under the terms and provisions of this Agreement, the Purchaser shall be responsible for the costs of collection, including reasonable attorneys' fees. There shall be a 1 1/2% service charge per month for all payments due and owing after 30 days. (Agreements are contingent upon strikes, accidents, or delays beyond our control.)

THIS ESTIMATE IS GOOD FOR 30 DAYS BASED ON THE CURRENT ECONOMIC CLIMATE. PRICING MAY CHANGE DUE UNFORSEEN MANUFACTURER PUBLISHED COST INCREASES BEYOND Overhead Door Company of Battle Creek - Jackson - Ann Arbor CONTROL. ALL ESTIMATES ARE BID COMPETITIVELY PER PLANS AND SPECIFICATIONS UNLESS OTHERWISE NOTED ABOVE. THIS ESTIMATE MAY INCREASE OR DECREASE BASED ON MANUFACTURER PUBLISHED ANNOUNCEMENTS.

We hereby propose to complete in accordance with above specification, for the sum of:

**Ninety Four Thousand One Hundred Forty Five Dollars and No Cents**

**\$94,145.00**

Signature

Manager



Direct Dial: 269-209-2332

**TERMS AND CONDITIONS**

Payment to be made as follows:

Prices subject to change if not accepted in \_\_\_\_\_ days.

BY OTHERS: Jambs, spring pads, all wiring to motors and control stations, unless otherwise stated above, are not included. Purchaser agrees that doors shall remain in Seller's possession until paid in full. In the event Purchaser breaches or defaults under the terms and provisions of this Agreement, the Purchaser shall be responsible for the costs of collection, including reasonable attorneys' fees. There shall be a 1 1/2% service charge per month for all payments due and owing after 30 days. (Agreements are contingent upon strikes, accidents, or delays beyond our control.)

ACCEPTANCE: Terms, Price, and specifications on all pages of this proposal are hereby accepted and the work authorized.

Purchaser: \_\_\_\_\_

Signature

Title

Date of Acceptance

**PROPOSAL**

TO: City Manager  
c/o Purchasing Agent  
City of Jackson, Michigan

Date: 1/9/2023

In compliance with your invitation for bids dated November 15, 2022 to perform  
**OVERHEAD DOOR REPLACEMENT AT CENTRAL FIRE STATION**

in the City of Jackson, the undersigned, a(n)

1. individual, resident of \_\_\_\_\_  
doing business as \_\_\_\_\_  
at \_\_\_\_\_


2. partnership, consisting of \_\_\_\_\_  
and \_\_\_\_\_  
under the firm name of \_\_\_\_\_

3. corporation by the name of Overhead Door Co. of Battle Creek-Jackson  
organized and existing under the laws of the State of Michigan *Ann Arbor*  
with offices at Battle Creek, Jackson + Ann Arbor  
(strike inapplicable clauses)

hereby proposes to perform said work, strictly as specified in the bid documents at the prices set forth on the attached schedule of bid prices, upon receipt of written notice of acceptance of this bid within ninety (90) calendar days after opening of the bids at the time stated in said Invitation; to execute a properly completed contract in the form provided with the bid documents in accordance with this bid; to give bond with good and sufficient surety or sureties, satisfactory to the City Attorney of Jackson, for the faithful performance of said contract, for payment of labor and materials, and, if required, for maintenance of work; and to give such bond within ten (10) days after notice of award.

FEDERAL ID# 38-2219913

(Corporate Seal, if applicable) Name of Bidder: Cameron Lafountain

Signed By: 

Its: Director of Sales

# BID SHEET

DATE:

**PROPOSAL FOR: OVERHEAD DOOR REPLACEMENT AT CENTRAL FIRE STATION**

TO: The Mayor and the City Council  
City of Jackson, Michigan

Ladies and Gentlemen:

The Undersigned has examined the plans, specifications, and the location of the above described work, and is fully informed as to the conditions relating to its performance, and understands the quantities shown in the estimate and on the plans are accurate to the best belief and knowledge of the Engineer, but are not guaranteed.

The undersigned hereby proposes to furnish all equipment, materials, supplies, labor, and services necessary to commence and complete the project as described in the Contract Documents; and in strict conformity with the requirements of the Specifications and such other special provisions and supplemental specifications as may be a part of this proposal for the above described project at the following unit prices all labor, equipment and materials necessary for completion of the work, but not specifically listed as a pay item, will be deemed to be included in one or more of the pay items listed in the bid sheet.

Bidder has examined and carefully studied the Bidding Documents, other related data identified in the Bidding Documents, and the following Addenda, receipt of which is hereby acknowledged (list addenda by Addendum Number and Date):

Addendum No.	Date
<u>1</u>	<u>1/3/2023</u>

<b>SCHEDULE OF BID PRICES</b> <b>NOTE: UNIT PRICES MUST BE LISTED AND SHALL GOVERN.</b>
--


DESCRIPTION	TOTAL COST
Lump sum per specifications	<u>\$94,145.00</u>
TOTAL BID WRITTEN OUT: <u>Ninety four thousand, one hundred forty five</u>	

<b>Submitted Bid:</b>	<u>\$94,145.00</u>
<b>Labor Costs:</b>	<u>\$17,500.00</u>
<b>Materials Costs:</b>	<u>\$76,645.00</u>

Equipment Costs:	N/A
Possible Change Orders:	Re-installation of Ceiling tiles Estimate: \$2,200. <sup>00</sup>

Bidder's Name:	Overhead Door Co of Battle Creek- Jackson - Ann Arbor
Address:	4407 W. Columbia Ave
City, State, Zip:	Battle Creek, MI 49015
Telephone:	800-962-3141
Fax:	N/A
Email Address:	cameron@ohdbc.com
Federal ID Number:	38-221 9913
Bid Signed By:	Cameron Lafontaine <span style="float: right;">Print or Type</span>
Title:	Director of Sales

1. I am the person described in and who executed the foregoing bid and that the several matters stated are in all respects true.
2. That I am an employee of the firm or company described in and I am authorized to submit said bid.

By  its Director of Sales

## CONTRACT COMPLIANCE

DATE: November 15, 2022  
TO: All Bidders  
FROM: City of Jackson  
SUBJECT: CONTRACT COMPLIANCE

The Commission of the City of Jackson, on 12/19/72, passed a resolution committing the City to a policy and procedure regarding compliance to affirmative hiring practices by contracting agencies doing business with the City of Jackson, effective 12/20/72.

The purpose of the policy and procedure is to ensure that all citizens of our community have the opportunity for the equality of treatment in service and employment.

The City requests that all bidders who will be doing business with the City in the amount of \$5,000 or more during any fiscal year, shall comply with the provisions of the Contract Compliance Policy.

Bidders will be required to show an Equal Employment Opportunity Certificate of Compliance or demonstrate compliance with standards for equal employment opportunity established by state and federal statute.

City Council of Jackson, Michigan

**CONTRACT COMPLIANCE**

CERTIFICATION


Overhead Door Co. certifies that he/she/it will not discriminate against any employee or applicant for employment with respect to hire, tenure, term, conditions, or privileges or employment because race, religion or national origin, color, age, sex, height, weight, marital status, sexual orientation, gender identity, and physical or mental handicap.

In connection with this commitment Overhead Door Co. understands that he/she/it name will be reviewed by the State of Michigan, Department of Civil Rights for determination of its status as an awardable Bidder.

The undersigned hereby agrees that he/she/it will abide by the terms of any agreements made with the City of Jackson in order to achieve awardable status.

Dated: 1/9/2023

By: Cameron Lafontain  
(Bidder's Name)

By:   
(Signature)

By: Director of Sales  
(Title)

4407 W. Columbia Ave  
Address

Battle Creek  
City

MI 49015  
State and Zip

## NON-DISCRIMINATION CLAUSE FOR ALL CITY OF JACKSON CONTRACTS

In connection with the performance of this contract, the contractor agrees as follows:

1. The contractor will not discriminate against any employee/employer for employment because of race, religion or national origin, color, age, sex, height, weight, marital status, sexual orientation, gender identity, and physical or mental handicap. The contractor will take affirmative action to ensure that minority applicants are employed, and that employees are treated during employment without regard to their race, religion, color, national origin, age, sex, height, weight, marital status or handicap. Such action shall include, but not be limited to, the following: layoff or termination, rates of pay or other forms of compensation, selection for training, upgrading or promotion, transfer or recruitment.
2. The contractor will, in all solicitations or advertisements for employees placed by or on behalf of the contractor, state that all qualified applicants will receive consideration for employment without regard to race, religion, color, national origin, age, sex, height, weight, marital status or handicap. As a disclaimer, the contractor may state in the advertisement that he/she is an equal opportunity employer.
3. The contractor will furnish and file compliance reports with the City of Jackson as requested. Such reports shall elicit information as to the practices, policies, program and employment statistics for the contractor and said contractor shall permit access to all books, records and accounts regarding employment practices by agents and representatives of the City duly charged with investigative duties to assure compliance with this clause.
4. Breach of the covenants herein may be regarded as a material breach of the contract, or purchasing agreement.
5. The contractor will include, or incorporate by reference, the provisions of paragraphs (1) through (4) in every subcontract or purchase order unless exempted by the rules, regulations or orders of the Michigan Civil Rights Commission and will provide in every subcontract or purchase order that said provisions will be binding upon each subcontractor or seller.

**EQUAL EMPLOYMENT OPPORTUNITY CERTIFICATION**


The undersigned understands and agrees that, as a Contractor for services, there shall be no discrimination against any employee or applicant for employment because of race, religion or national origin, color, age, sex, height, weight, marital status, sexual orientation, gender identity, and physical or mental handicap, including but no limited to employment, upgrading, demotion, or transfer; recruitment or recruitment advertising; layoff or termination; rates of pay or other forms of compensation and selection for training.

The Contractor further agrees to the following:

- (a) It will assist and actively cooperate with the City in obtaining compliance of any subcontractors with the equal opportunity rules, regulations, and relevant orders.
- (2) It will furnish the City such information as might be required for the supervision of its compliance program, and will otherwise assist the City in the discharge of its responsibility for ensuring compliance.
- (3) In the event that the Contractor fails or refuses to comply with the equal opportunity regulations, the City may cause to be canceled, terminated, or suspended in whole or in part the contractual arrangement between the City and the Contractor.

NAME OF BIDDER: Overhead Door Co. Battle Creek - Jackson - Ann Arbor

ADDRESS: 4407 W. Columbia Ave  
Battle Creek, MI 49015

SIGNED BY: 

TITLE: Director of Sales

DATE: 1/9/2023

**CERTIFICATION OF NONSEGREGATED FACILITIES**

The bidder certifies that he does not maintain or provide for his employees any segregated facilities and do not permit his employees to perform their services at any location, under his control, where segregated facilities are maintained. The bidder certifies further that he will not maintain or provide for his employees any segregated facilities at any of his establishments, and that he will not permit his employees to perform their services at any location under his control where segregated facilities are maintained. The bidder agrees that a breach of this certification will be a violation of the Equal Opportunity clause in any contract resulting from acceptance of this bid. As used in this certification, the term "segregated facilities" means any waiting rooms, work areas, restrooms and washrooms, restaurants and other eating areas, time clocks, locker rooms and other storage or dressing areas, parking lots, drinking fountains, recreation or entertainment areas, transportation, and housing facilities provided for employees which are segregated by explicit directive or are in fact segregated on the basis of race, color, religion, or national origin, because of habit, local custom, or otherwise. The bidder agrees that (except where he has obtained identical certification from proposed subcontractors for specific time periods) he will obtain identical certification from proposed subcontractors prior to the award of subcontracts exceeding \$10,000 which are not exempt from the provisions of the Equal Opportunity clause, and that he will retain such certifications in his files.

Dated: 1/9/2023

By: Overhead Door Co. Battle Creek - Jackson - Ann Arbor  
(Bidder's Name)

By:   
(Signature)

By: Director of Sales  
(Title)

4407 W. Columbia Ave  
Address

Battle Creek  
City

MI 49015  
State and Zip

**NON-COLLUSION AFFIDAVIT OF PRIME BIDDER**

STATE OF Michigan )  
COUNTY OF Calhoun ) ss

Cameron LaFountain, being first duly sworn, deposed and says that:

1. He is Director of Sales of Overhead Door Co of Jackson the Bidder that has submitted the attached bid;
2. He is fully informed respecting the preparation and contents of the attached bid and of all pertinent circumstances respected such bid;
3. Such bid is genuine and is not a collusive or sham bid;
4. Neither the said Bidder nor any of its officers, partners, owners, agents, representatives, employees or parties in interest, including this affiant, has in any way colluded, conspired, connived or agreed, directly or indirectly with any other Bidder, firm or person to submit a collusive or sham bid in connection with the contract for which the attached bid has been submitted or to refrain from bidding in connection with such contract, or has in any manner, directly or indirectly, sought by agreement or collusion or communication or conference with any other Bidder, firm or person to fix the price or prices in the attached bid or of any other Bidder, or to fix any overhead, profit or cost element of the bid price or the bid price of any other Bidder, or to secure through any collusion, conspiracy, connivance or unlawful agreement any advantage against the City of Jackson or any person interested in the proposed contract; and
5. The price or prices quoted in the attached bid are fair and proper and are not tainted by any collusion, conspiracy, connivance or unlawful agreement on the part of the Bidder or any of its agents, representatives, owners, employees, or parties in interest, including this affiant.

Dated: 1-9-2023 By: [Signature]  
(Company)

By: Director of Sales  
(Title)

Subscribed and sworn to before me, a Notary Public, this 9 day of Jan, 2023  
20    .

[Signature]

Notary Public, Calhoun County,  
My commission expires: 5-20-24

TRICIA GARLAND  
NOTARY PUBLIC, CALHOUN COUNTY, MI  
MY COMMISSION EXPIRES MAY 20, 2024  
ACTING IN THE COUNTY OF Calhoun

**SECTION C**

Subcontractors

Each bidder shall indicate below the name, address, and a complete description of work to be performed by each subcontractor on this project and if they are a minority or woman owned business.

N/A (We self Perform)

**RIGHT TO KNOW  
CONTRACTOR RELEASE FORM**

I, Cameron Lafontaine an authorized representative of Overhead Door Co am aware that as a requirement to perform work for the City of Jackson on a contractual basis, I must have provided my employees with the basic training requirements of the HAZARD COMMUNICATION STANDARD as prescribed by the Michigan Right to Know amendments to Act 154 of the Public Acts of 1974 (Act 80, Public Acts 1986), prior to starting any work for the City. While engaged in working for the City, I will continue to comply with Michigan Right to Know Law until completion of the contract.

I am aware that if I bring any hazardous chemical to the City's work place, I must have available the MSDS for these chemicals, in a place accessible to all employees in the work place. If necessary, due to the "special protection information" requirement stated on the MSDS for the chemicals, I will provide all employees with any special training, ~~special protective clothing or equipment~~ necessary to eliminate or lessen the possible exposure to the hazardous chemical or chemicals.

By execution of this Release, the contractor acknowledges that he and all subcontractors and suppliers, will comply with all requirements of the HAZARD COMMUNICATION STANDARD. Further, the contractor shall hold harmless from and indemnify the City against all claims, suits, actions, costs, counsel fees, expenses, damages, judgements or decrees, by reason of his failure, or the failure of any subcontractor, suppliers, or any person employed under said contractor to comply with the requirements of Act 154 of the Public Acts of 1974 as amended.

Dated 1/19/2023

  
Signature



## City of Jackson Ethics Disclosure Form Vendors and Contractors

Name <i>Cameron Lafountain</i>	Company <i>Overhead Door Co.</i>
Telephone <i>800-962-3141</i>	Email Address <i>Cameron@ohdbc.com</i>

Contract or matter pending with the City:

\_\_\_\_\_

\_\_\_\_\_

I, \_\_\_\_\_, being duly sworn, and pursuant to City of Jackson Ordinance No. 2015-18, I hereby disclose and swear to the following (check all that apply and provide details below):

- I, or my company's owners, members, major shareholders, or corporate officers, have a financial interest in a contract or matter pending before Jackson City Council.
- A relative<sup>1</sup> or immediate family member<sup>2</sup> of myself or my company's owners, members, major shareholders, or corporate officers has a financial interest in a contract or matter pending before a City office, department, board, or commission.
- I, or my company's owners, members, major shareholders, or corporate officers, have an interest in real or personal property that is subject to a decision by the City regarding the purchase, sale, lease, zoning, property improvements, NOORPR or FVA registration, a development agreement, or a special tax designation or abatement.

Property address: \_\_\_\_\_

Property interest: \_\_\_\_\_

- An immediate family member or relative of myself or my company's owners, members, major shareholders, or corporate officers, has a financial interest in real or personal property that is subject to a decision by the City regarding the purchase, sale, lease, zoning, property improvements, NOORPR or FVA registration, a development agreement, or a special tax designation or abatement.

<sup>1</sup> Relative means any spouse, domestic partner, great grandparents, step great grandparents, grandparents, step grandparents, sons, stepsons, daughters, step daughters, grandsons, step grandsons, granddaughters, step granddaughters, brothers, step brothers, sisters, step sisters, and in-laws of a Public Employee, the Mayor, an Elected Official, an Appointed Official, a member of a Board or Commission, a Contractor, or an Advisor of the City.

<sup>2</sup> Immediate family member means a Public Employee, the Mayor, an Elected Official, an Appointed Official, a member of a Board or Commission, a Contractor, or an Advisor's spouse, domestic partner, individual who lives in the Public Employee's household or an individual claimed by a Public Employee or a Public Employee's spouse as a dependent under the United States Internal Revenue Code at 26 USC 1, et seq.

Property address: \_\_\_\_\_

Property interest: \_\_\_\_\_

- An immediate family member or relative of myself or my company's owners, members, major shareholders, or corporate officers, is employed by the City or making an application for employment to the City.

Relative name: \_\_\_\_\_

City Department: \_\_\_\_\_

- I, or my company's owners, members, major shareholders, or corporate officers, have made campaign contributions in the last year to a candidate running for elective office with the City.

Name of Candidate: \_\_\_\_\_

Amount of Campaign Contribution: \_\_\_\_\_

The following entities and persons have a financial interest in the contract or matter identified above: \_\_\_\_\_

\_\_\_\_\_  
\_\_\_\_\_  
\_\_\_\_\_

Additional information regarding any of the above:

\_\_\_\_\_  
\_\_\_\_\_  
\_\_\_\_\_

- None of the above apply.

Dated: 1/9/2023

[Signature]  
Signature

STATE OF MICHIGAN     )  
  ) SS  
COUNTY OF JACKSON    )

The foregoing instrument was acknowledged before me this 9 day of Jan, 2023.  
By [Signature]

TRICIA GARLAND  
NOTARY PUBLIC, CALHOUN COUNTY, MI  
MY COMMISSION EXPIRES MAY 20, 2024  
ACTING IN THE COUNTY OF Calhoun



## Responsible Contractor Ordinance

Below are twenty-nine (29) Responsibility Criteria that must be answered per the City's Responsible Contractor Ordinance. For each criterion provide a relevant response or attachments as required.

Answers to these criteria will not exclude any bidder from the bid process or ultimate award.

<b>CRITERIA 1:</b>	
COMPANY NAME:	Overhead Door Co. Battle Creek - Jackson - Ann Arbor
ADDRESS:	4407 W. Columbia Ave
CITY, STATE, ZIP:	Battle Creek, MI 49015
TELEPHONE:	800-962-3141
OFFICERS:	
President: Dave Whitaker	Email Address: dwhit@ohdbc.com
Vice President:	Email Address:
Secretary:	Email Address:
Treasurer: Carla Whitaker	Email Address: carla@ohdbc.com
<b>CRITERIA 2:</b>	
How many years has your organization been in business under your present firm name?	
PARENT COMPANY NAME:	Overhead Door Co of Battle Creek
STREET ADDRESS:	4407 W. Columbia Ave
CITY, STATE, ZIP CODE:	Battle Creek, MI 49015
UNDER CURRENT MANAGEMENT SINCE (DATE):	1978

\* For all criteria's that require attachments and/or documentation, I can provide electronic forms

**CRITERIA 3:**

State and local licenses and license numbers held by your organization:

N/A

What are your formal training programs: a) apprentice/journeyman, b) other comparable formal training programs?

- Manufacturer supplied training
- OSHA Training
- CPR - Training

**CRITERIA 4:**

Confirmation that all subcontractors, employees and other individuals working on the construction project will maintain current applicable licenses required by law for all licensed occupations and professions.

Confirmed

**CRITERIA 5:**

Verification that the bidder is in compliance with all applicable state and federal laws and visa requirements regarding the hiring of non-US citizens, and disclosure of any work visas sought or obtained by the bidder, any of the bidder's subcontractors, or any of the bidder's employees or independent contractors, in order to perform any portion of the project.

In Compliance

**CRITERIA 6 (ATTACHMENT REQUIRED)**

Attach evidence of experience with construction techniques, trade standards, quality workmanship, project scheduling, cost control, management of projects of comparable size/complexity, and building codes by documenting the bidder's ability and capacity to perform the project. The bidder must identify those portions of the project it reasonably believes will be subcontracted and the names of the subcontractors.

**CRITERIA 7 (ATTACHMENT REQUIRED)**

Evidence of bonding capacity within the past twelve (12) months, that the applicant has financial resources to start up and follow through on the project(s) and to respond to damages in case of default as shown by written verification of bonding capacity equal to or exceeding the amount of the bidder's scope of work on the project. The written verification must be submitted by a licensed surety company rated "B+" (or better) in the current A.M. Best Guide and qualified to do business within the State of Michigan.

**CRITERIA 8:**

A list of all litigation and arbitrations currently pending and within the past five (5) years, including an explanation of each (parties, court/forum, legal claims, damages sought, and resolution).

  /   NONE

**CRITERIA 9:**

Disclosure of any violations of state, federal or local laws or regulations, including OSHA or MIOSHA violations, state or federal prevailing wage laws, wage and hour laws, worker's compensation or unemployment compensation laws, rules or regulations, issued to or against the bidder within the past five years.

  /   NONE

**CRITERIA 10:**

Disclosure of any debarment by any federal, state or local governmental unit and/or findings of non-responsibility or non-compliance with respect to any public or private construction project performed by the bidder.

  /   NONE

**CRITERIA 11:**

Proof of insurance, including certificates of insurance, confirming existence and amount of coverage for liability, property damage, workers compensation, and any other insurances required by the proposed contract documents.

Name:	Lighthouse
Type of Coverage:	Commercial General Liability, Automobile liability, Umbrella liability + Workers Compensation
Telephone:	269-381-4643
Are you self-insured for Worker's Compensation Insurance? Yes <input type="checkbox"/> No <input checked="" type="checkbox"/>	

**CRITERIA 12 (ATTACHMENT REQUIRED):**

A statement regarding the bidder's staffing capabilities and labor sources including subcontractors and a verification from the bidder that construction workers will not be misclassified as independent contractors in violation of state or federal law.

**CRITERIA 13:**

Verification of an existing Fitness for Duty Program (drugs and alcohol) of each employee working on the proposed jobsite.

Yes, we have a Fitness for Duty Program

No, we do not have a Fitness for Duty Program

Additional Information:

**CRITERIA 14:**

A warranty statement regarding labor, equipment and materials.

*1-Year labor/Workmanship*

*Manufacturers warranty*

**CRITERIA 15:**

A statement affirming that the firm will pay all craft employees that it employs on the project the current wage rates and fringe benefits as required under applicable federal, state, or local wage laws.

*We are an open shop specialty Contractor*

**CRITERIA 16:**

A statement from the contractor or subcontractor acknowledging their obligation to comply with this Ordinance in each contract and subcontract.

We comply

**CRITERIA 17:**

A statement identifying what possible change orders could be necessary and what their approximate subsequent total costs would be.

A possible CO would be re-installing the ceiling tiles in the truck bays. Estimated add: \$2,200.<sup>00</sup>

**CRITERIA 18:**

Qualifications of management and supervisory personnel to be assigned by the bidder.

Manager has 42 years experience

**CRITERIA 19 (ATTACHMENT REQUIRED):**

References from individuals or entities the bidder has worked for within the last five (5) years including information regarding records of performance and job site cooperation.

**CRITERIA 20:**

Evidence of any quality assurance program used by the bidder and the results of any such program on the bidder's previous projects.

DASMA

**CRITERIA 21:**

Assurance that all construction work for this project must proceed economically, efficiently, continuously and without interruption.

Our plan is to do one door at a time in it's entirety.  
This will limit the number of doors out of commission at one time

**CRITERIA 22 (ATTACHMENT REQUIRED):**

A list of projects completed within the past five (5) years of comparable size/complexity, including dates, clients, approximately dollar value, and size. Documentation from these previous projects including but not limited to all extra costs relating to the bidder's timeliness, performance, quality of work, extension requests, contractual fines and penalties imposed, liens filed, history of claims for extra work and any contract defaults with an explanation of the reason for the default and how the default was resolved.

**CRITERIA 23:**

The ratio of masters or journeypersons to apprentices proposed to be used on the construction project job site, if apprentices are to be used on the project.

N/A

Do you participate in the Registered Apprenticeship Programs that are registered with the United States Department of Labor Office of Apprenticeship or by a State Apprenticeship Agency recognized by the Office of Apprenticeship?

Yes

No

Additional Information:

**(ATTACHMENT REQUIRED)** Documentation of how the bidder assesses the skills and qualifications of any employees who do not have master or journeyperson certification or status, or are not participants in a Registered Apprenticeship Program.

**CRITERIA 24 (ATTACHMENT REQUIRED)**

Evidence of the bidder's worker's compensation Experience Modification Rating ("EMR"). Preference will be given to contractors and subcontractors who exhibit an EMR of 1.0 or less based on a three-year average.

**CRITERIA 25:**

All craft labor that will be employed by the firm for the project has completed at least the OSHA 10 hour training course of safety established by the U.S. Department of Labor, Occupational Safety & Health Administration.

Yes

No

**CRITERIA 26 (ATTACHMENT REQUIRED):**

Documentation of master or journeyman certification or status for masters and journeymen to be used on the project, and the source of such certification or status

**CRITERIA 27:**

A statement from the bidder as to what percentage of its workforce can be drawn significantly from area residents because a goal of the City is to utilize, in its construction activities, local residents as much as is economically feasible while retaining the high quality of construction required for its construction activities, consistent with applicable law. The City will consider in evaluating which bids best serve its interests, the extent to which responsible and qualified bidders are able to achieve this goal.

*All workforce resides in area*

**CRITERIA 28 (ATTACHMENT REQUIRED):**

Evidence of Equal Employment Opportunity Programs for minorities, women, veterans, returning citizens, and small businesses.

**CRITERIA 29:**

Assurance that the bidder is an equal opportunity employer and does not discriminate on the basis of race, sex, pregnancy, age, religion, national origin, marital status, sexual orientation, gender identity of expression, height, weight, or disability. **COMPANIES EQUAL EMPLOYMENT OPPORTUNITY STATEMENT:**

*We are an equal opportunity employer*

*Overhead Door Co. of Battle Creek - Jackson - Ann Arbor*

Print Firm Name/Principal

*[Handwritten Signature]*

Signature/Principal

*1/9/2023*

Date

## RESPONSIBLE CONTRACTOR BID EVALUATION CRITERIA

Once the City deems a contractor a responsible bidder, having used the process identified above, the City must consider the contractor's bid. The City must consider, at minimum, each of the evaluation criteria listed in this Section in determining the best bid. The City may require contractors or subcontractors to provide additional information by inclusion in bid documents. Additionally, the list set forth below in no way limits any additional criteria that the City may deem relevant for purposes of making a determination of the best bid.

Bid documents must require any contractor or subcontractor bidding on the project to submit written responses and other information and documentation regarding the listed criteria and any other criteria specified by the City through the bid documents. The City may request additional information or explanation from any contractor or subcontractor regarding any particular criteria. The bid documents must provide that the City retains the right in its discretion to reject any and all bids. All required contractor financial and privileged information must be kept from public disclosure unless otherwise required by law.

Submitted bids must break out labor costs from material and equipment costs.


For each separate bid package, the City in its discretion will weigh the information provided by the contractor or subcontractor regarding the evaluating criteria, as a whole, to determine the best bid. Except as otherwise required by law, no single criterion will necessarily be determinative in assessing which bid is the best bid. The Purchasing Department must weigh each of the criteria based on a distribution of percentage points on a 100-point scale. Additionally, The Purchasing Department shall provide space on the bid evaluation form for the prospective bidder to include additional information about themselves and/or their bid – this section would be optional for the prospective bidder to fill out. The criteria to be considered in bid evaluation on construction projects by the City shall be weighed categorically as follows, and shall include:

### Price (25%)

1. A statement identifying what possible change orders could be necessary and what their approximate subsequent total costs would be.

<b>Submitted Bid:</b>	\$94,145. <sup>00</sup>
<b>Labor Costs:</b>	\$17,500. <sup>00</sup>
<b>Materials Costs:</b>	\$76,645. <sup>00</sup>
<b>Equipment Costs:</b>	N/A
<b>Possible Change Orders:</b>	\$2,200. <sup>00</sup>

# DEPARTMENTAL REPORT

**MEMO TO:** Jonathan Greene, City Manager  
**FROM:** Elmer J. Hitt, Director of Police and Fire Services   
**DATE:** January 24, 2023  
**RECOMMENDATION:** Accept Bid by R. W. Mercer

---

## SUMMARY

The Jackson Fire Department's Central Station at 518 North Jackson Street has been the primary station since it was built in 1962. The windows in the building are those originally installed during its construction. More than 60 years have passed, and the windows are in dire need of replacement.

## BUDGETARY CONSIDERATIONS

Bids were solicited for the project. A bid from R. W. Mercer for \$86,600 was the only bidder who submitted all required documents. Their bid is under the amount budgeted in FY 22/23.

## HISTORY, BACKGROUND and DISCUSSION

Since the early 1960s when the building was built, much has changed in the construction field. Advances have been made to make windows more energy-efficient and with safer materials. The current windows are degrading with each passing year, and there are concerns surrounding the asbestos used as construction materials in the past.

## DISCUSSION OF THE ISSUE

The Fire Department would save on energy costs in future years, which will add to the cost savings with Mercer's bid be under the budgeted amount. This project would also make the building safer for the firefighters who work there.

## POSITION

I recommend accepting the bid by R.W. Mercer for the windows update project at the Central Fire Station.

---

ATTACHMENTS

**MEMO TO:** Mayor and City Councilmembers  
**FROM:** Jonathan Greene, City Manager  
**DATE:** January 24, 2023  
**SUBJECT:** Windows Update Project at Jackson Fire Department Station #1

---

**Recommendation:**

Accept bid by R.W. Mercer

Attached is a memorandum from Director Elmer Hitt regarding the windows at the fire station on N. Jackson St.

I recommend accepting the bid by R.W. Mercer. Your consideration and concurrence is appreciated.

# American Institute of Architects

AIA Document A310

## Bid Bond

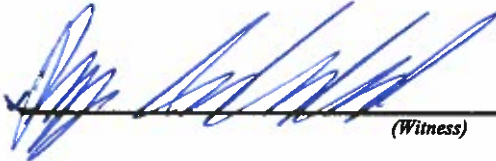
KNOW ALL MEN BY THESE PRESENTS, that we, R.W. Mercer Company, as Principal, hereinafter called the Principal, and Nationwide Mutual Insurance Company, duly organized under the laws of the State of Ohio, as Surety, hereinafter called the Surety, are held and firmly bound unto City of Jackson, as Obligee, hereinafter called the Obligee, in the sum of FIVE Percent of the Amount Bid ( 5 % of the Bid Amount), for the payment of which sum well and truly to be made, the said Principal and the said Surety, bind ourselves, our heirs, executors, administrators, successors and assigns, jointly and severally, firmly by these presents.

WHEREAS, the Principal has submitted a bid for: **Central Fire Station Window Replacement**

**Bid Date: January 10, 2023**

NOW, THEREFORE, if the Obligee shall accept the bid of the Principal and the Principal shall enter into a Contract with the Obligee in accordance with the terms of such bid, and give such bond or bonds as may be specified in the bidding or Contract Documents with good and sufficient surety for the faithful performance of such Contract and for the prompt payment of labor and materials furnished in the prosecution thereof, or in the event of the failure of the Principal to enter such Contract and give such bond or bonds, if the Principal shall pay to the Obligee the difference not to exceed the penalty hereof between the amount specified in said bid and such larger amount for which the Obligee may in good faith contract with another party to perform the Work covered by said bid, then this obligation shall be null and void, otherwise to remain in full force and effect.

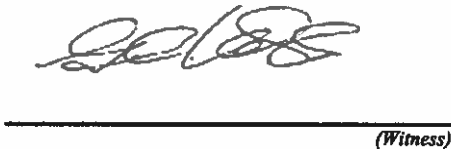
Signed and sealed this 10th day of January, A.D. 2023.

  
(Witness)

R.W. Mercer Company

(Principal)

  
(Title)

  
(Witness)

Nationwide Mutual Insurance Company

(Surety)





**James S. Kurowski**

Attorney -in-Fact

Power of Attorney

KNOW ALL MEN BY THESE PRESENTS THAT:

Nationwide Mutual Insurance Company, an Ohio corporation

hereinafter referred to severally as the "Company" and collectively as "the Companies" does hereby make, constitute and appoint:  
GAIL A KUROWSKI; JAMES S KUROWSKI

each in their individual capacity, its true and lawful attorney-in-fact, with full power and authority to sign, seal, and execute on its behalf any and all bonds and undertakings, and other obligatory instruments of similar nature, in penalties not exceeding the sum of

**UNLIMITED**

and to bind the Company thereby, as fully and to the same extent as if such instruments were signed by the duly authorized officers of the Company; and all acts of said Attorney pursuant to the authority given are hereby ratified and confirmed.

This power of attorney is made and executed pursuant to and by authority of the following resolution duly adopted by the board of directors of the Company:

"RESOLVED, that the president, or any vice president be, and each hereby is, authorized and empowered to appoint attorneys-in-fact of the Company, and to authorize them to execute and deliver on behalf of the Company any and all bonds, forms, applications, memorandums, undertakings, recognizances, transfers, contracts of indemnity, policies, contracts guaranteeing the fidelity of persons holding positions of public or private trust, and other writings obligatory in nature that the business of the Company may require; and to modify or revoke, with or without cause, any such appointment or authority; provided, however, that the authority granted hereby shall in no way limit the authority of other duly authorized agents to sign and countersign any of said documents on behalf of the Company."

"RESOLVED FURTHER, that such attorneys-in-fact shall have full power and authority to execute and deliver any and all such documents and to bind the Company subject to the terms and limitations of the power of attorney issued to them, and to affix the seal of the Company thereto; provided, however, that said seal shall not be necessary for the validity of any such documents."

This power of attorney is signed and sealed under and by the following bylaws duly adopted by the board of directors of the Company.

Execution of Instruments. Any vice president, any assistant secretary or any assistant treasurer shall have the power and authority to sign or attest all approved documents, instruments, contracts, or other papers in connection with the operation of the business of the company in addition to the chairman of the board, the chief executive officer, president, treasurer or secretary; provided, however, the signature of any of them may be printed, engraved, or stamped on any approved document, contract, instrument, or other papers of the Company.

IN WITNESS WHEREOF, the Company has caused this instrument to be sealed and duly attested by the signature of its officer the 20th day of August, 2021.

Antonio C. Albanese, Vice President of Nationwide Mutual Insurance Company

ACKNOWLEDGMENT

STATE OF NEW YORK COUNTY OF NEW YORK: ss

On this 20th day of August, 2021, before me came the above-named officer for the Company aforesaid, to me personally known to be the officer described in and who executed the preceding instrument, and he acknowledged the execution of the same, and being by me duly sworn, deposes and says, that he is the officer of the Company aforesaid, that the seal affixed hereto is the corporate seal of said Company, and the said corporate seal and his signature were duly affixed and subscribed to said instrument by the authority and direction of said Company.



Stephanie Rubino McArthur  
Notary Public, State of New York  
No. 02MC6270117  
Qualified in New York County  
Commission Expires October 19, 2024

Notary Public  
My Commission Expires  
October 19, 2024

CERTIFICATE

I, Laura B. Guy, Assistant Secretary of the Company, do hereby certify that the foregoing is a full, true and correct copy of the original power of attorney issued by the Company; that the resolution included therein is a true and correct transcript from the minutes of the meetings of the boards of directors and the same has not been revoked or amended in any manner; that said Antonio C. Albanese was on the date of the execution of the foregoing power of attorney the duly elected officer of the Company, and the corporate seal and his signature as officer were duly affixed and subscribed to the said instrument by the authority of said board of directors; and the foregoing power of attorney is still in full force and effect.

IN WITNESS WHEREOF, I have hereunto subscribed my name as Assistant Secretary, and affixed the corporate seal of said Company this 10th day of January, 2023.

Assistant Secretary



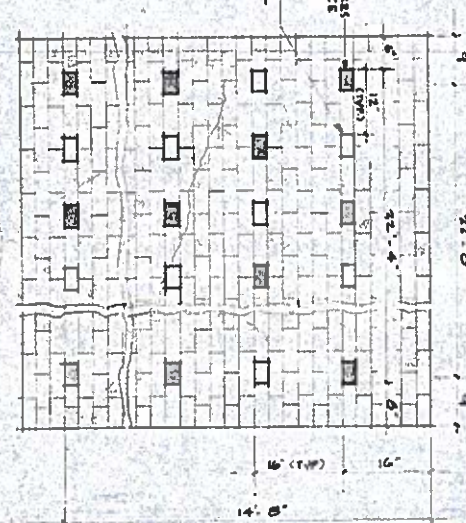
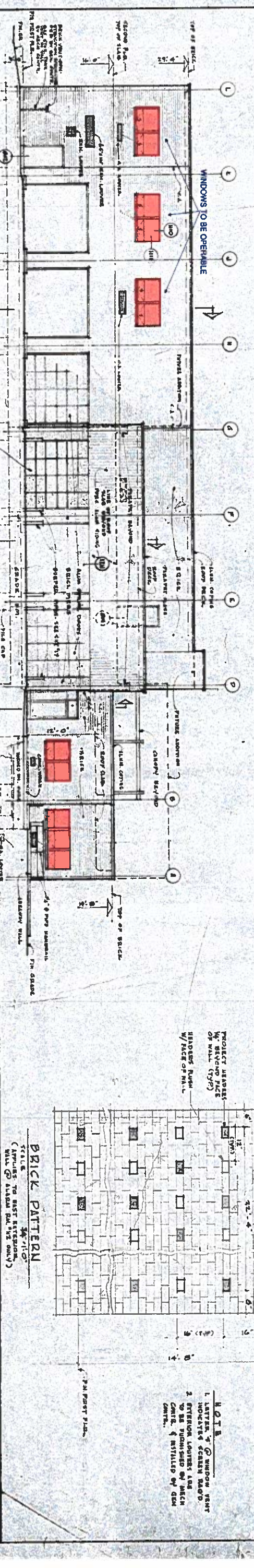
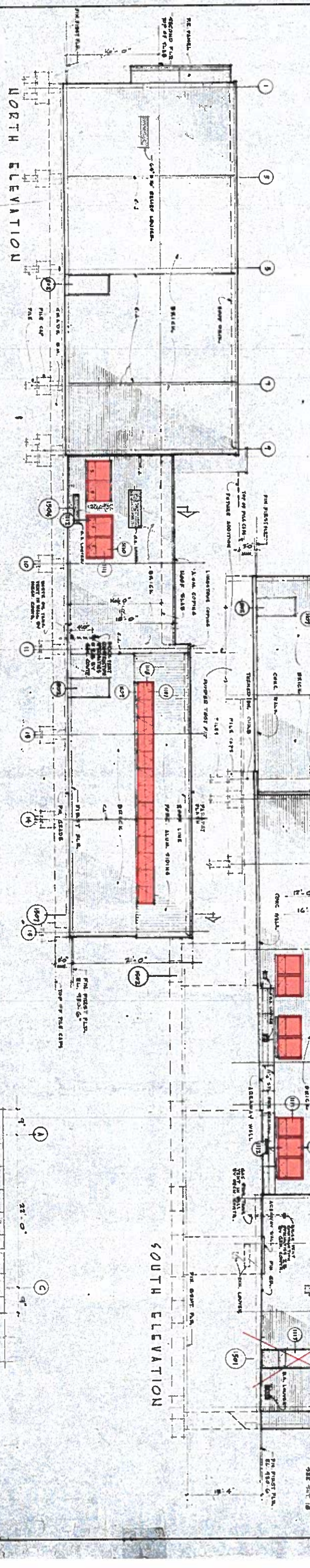
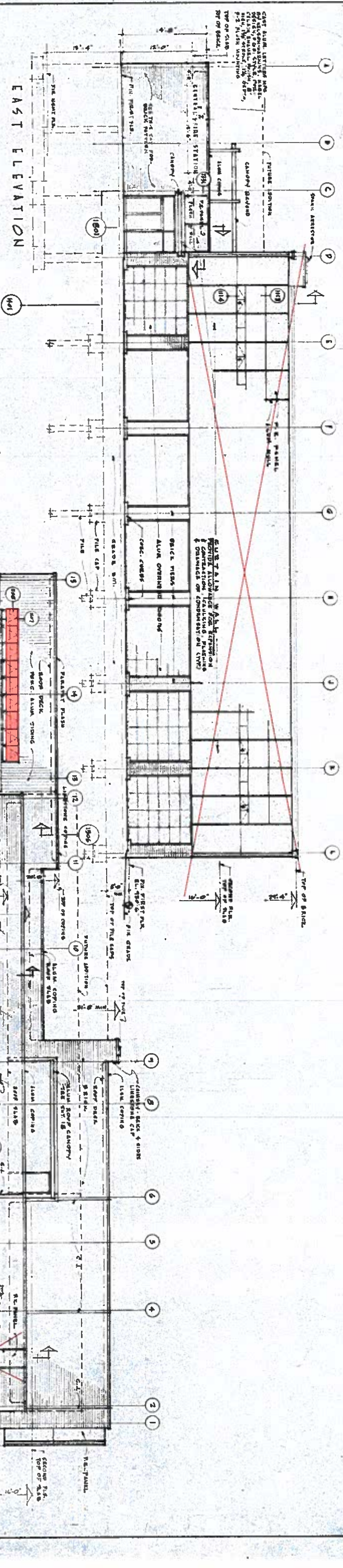
2322 Brooklyn Road, P.O. Box 180, Jackson, MI 49204-0180  
(517) 787-2960 (phone) / (517) 787-1970 (fax)

---

## **WINDOW REPLACEMENT AT CENTRAL FIRE STATION – CITY OF JACKSON**

### **RW MERCER QUALIFICATION LIST**

- 1. RW MERCER HAS INCLUDES A \$500 ALLOWANCE FOR THE BUILDING PERMIT. RW MERCER HAS ALSO INCLUDED THE PLM AND MAINTENANCE & GUARANTEE BONDS.**
- 2. RW MERCER HAS ONLY INCLUDED WINDOW REPLACEMENT FOR THE WINDOWS HIGHLIGHTED IN RED ON THE ATTACHED PAGE. NO WINDOWS ON FRONT OF THE BUILDING FIGURED ON BEING REPLACED AT THIS TIME.**
- 3. RW MERCER HAS FIGURED ALL OF THE WORK TO BE COMPLETED DURING NORMAL BUSINESS HOURS**
- 4. RW MERCER DID NOT FIGURED ANY NEW BLINDS TO BE FURNISHED AND INSTALLED FOR THIS PROJECT.**
- 5. RW MERCER HAS NOT FIGURED ANY NEW INTERIOR WINDOW SILLS IN THE BASE BID**
- 6. RW MERCER BID DOES NOT INCLUDE ANYTHING FOR THE OVERHEAD DOOR PROJECT.**



- NOTE**
1. LETTER 'O' WINDOW VENT
  2. LETTER 'O' WINDOW VENT
  3. LETTER 'O' WINDOW VENT
  4. LETTER 'O' WINDOW VENT

**ELEVATIONS**

**CITY OF JACKSON, MICHIGAN**

**CENTRAL FIRE STATION**

**JACKSON, MICHIGAN**

**SYNCRON, HANSEN & ASSOCIATES**

**ARCHITECTS**

**A. CHARLES JONES ASSOCIATES**

**ARCHITECTS**

**ASSOCIATED ARCHITECTS**

## CHECKLIST FOR BID SUBMITTAL

X BID BOND – If a bid bond is required, please submit your bid bond with your bid documents

X PROPOSAL SHEETS – Please fill out and have notarized your proposal sheets

X SAMS.GOV - Please register with SAM.GOV to be eligible to work on federally funded projects. Registration is free.

<https://sam.gov/content/entity-registration>

Please provide your sams.gov Unique Identity Number: #46SD6  
if you have received it.

# PROPOSAL

TO: City Manager  
c/o Purchasing Agent  
City of Jackson, Michigan

Date: 1/9/2023

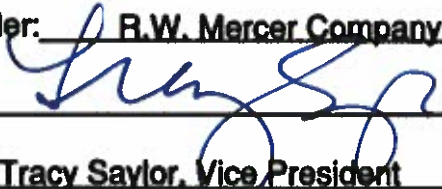
In compliance with your invitation for bids dated November 15, 2022 to perform  
**WINDOW REPLACEMENT AT CENTRAL FIRE STATION**

in the City of Jackson, the undersigned, a(n)

1. individual, resident of \_\_\_\_\_  
doing business as \_\_\_\_\_  
at \_\_\_\_\_
2. partnership, consisting of \_\_\_\_\_  
and \_\_\_\_\_  
under the firm name of \_\_\_\_\_
3. corporation by the name of R.W. Mercer Company  
organized and existing under the laws of the State of Michigan  
with offices at 2322 Brooklyn Road, Jackson, MI 49203  
(strike inapplicable clauses)

hereby proposes to perform said work, strictly as specified in the bid documents at the prices set forth on the attached schedule of bid prices, upon receipt of written notice of acceptance of this bid within ninety (90) calendar days after opening of the bids at the time stated in said Invitation; to execute a properly completed contract in the form provided with the bid documents in accordance with this bid; to give bond with good and sufficient surety or sureties, satisfactory to the City Attorney of Jackson, for the faithful performance of said contract, for payment of labor and materials, and, if required, for maintenance of work; and to give such bond within ten (10) days after notice of award.

FEDERAL ID# 38 - 2120488

(Corporate Seal, if applicable) Name of Bidder: R.W. Mercer Company  
Signed By:   
Its: Tracy Saylor, Vice President

# BID SHEET

DATE:

**PROPOSAL FOR: WINDOW REPLACEMENT AT CENTRAL FIRE STATION**

**TO: The Mayor and the City Council  
City of Jackson, Michigan**

**Ladies and Gentlemen:**

The Undersigned has examined the plans, specifications, and the location of the above described work, and is fully informed as to the conditions relating to its performance, and understands the quantities shown in the estimate and on the plans are accurate to the best belief and knowledge of the Engineer, but are not guaranteed.

The undersigned hereby proposes to furnish all equipment, materials, supplies, labor, and services necessary to commence and complete the project as described in the Contract Documents; and in strict conformity with the requirements of the Specifications and such other special provisions and supplemental specifications as may be a part of this proposal for the above described project at the following unit prices all labor, equipment and materials necessary for completion of the work, but not specifically listed as a pay item, will be deemed to be included in one or more of the pay items listed in the bid sheet.

Bidder has examined and carefully studied the Bidding Documents, other related data identified in the Bidding Documents, and the following Addenda, receipt of which is hereby acknowledged (list addenda by Addendum Number and Date):

Addendum No.	Date
<b>#1</b>	<b>1.3.2022</b>

**SCHEDULE OF BID PRICES**  
**NOTE: UNIT PRICES MUST BE LISTED AND SHALL GOVERN.**


DESCRIPTION	TOTAL COST
Lump sum per specifications	<b>\$86,600.00</b>
<b>TOTAL BID WRITTEN OUT: Eighty-Six Thousand Six Hundred</b>	

<b>Submitted Bid:</b>	<b>\$86,600.00</b>
<b>Labor Costs:</b>	<b>\$34,650.00</b>

<b>Materials Costs:</b>	<b>\$43,290.00</b>
<b>Equipment Costs:</b>	<b>\$8,660.00</b>
<b>Possible Change Orders:</b>	<b>N/A</b>

<b>Bidder's Name:</b>	<b>R.W. Mercer Company</b>
<b>Address:</b>	<b>2322 Brooklyn Road</b>
<b>City, State, Zip:</b>	<b>Jackson, MI 49203</b>
<b>Telephone:</b>	<b>(517) 787-2960</b>
<b>Fax:</b>	<b>(517) 787-1960</b>
<b>Email Address:</b>	<b>tracy@rwmercer.com</b>
<b>Federal ID Number:</b>	<b>38-2120488</b>
<b>Bid Signed By:</b>	<b>Print or Type</b>
<b>Title:</b>	<b>Vice President</b>

1. I am the person described in and who executed the foregoing bid and that the several matters stated are in all respects true.
2. That I am an employee of the firm or company described in and I am authorized to submit said bid.

By  Its Vice President

## **CONTRACT COMPLIANCE**

**DATE:** November 15, 2022  
**TO:** All Bidders  
**FROM:** City of Jackson  
**SUBJECT:** CONTRACT COMPLIANCE

The Commission of the City of Jackson, on 12/19/72, passed a resolution committing the City to a policy and procedure regarding compliance to affirmative hiring practices by contracting agencies doing business with the City of Jackson, effective 12/20/72.

The purpose of the policy and procedure is to ensure that all citizens of our community have the opportunity for the equality of treatment in service and employment.

The City requests that all bidders who will be doing business with the City in the amount of \$5,000 or more during any fiscal year, shall comply with the provisions of the Contract Compliance Policy.

Bidders will be required to show an Equal Employment Opportunity Certificate of Compliance or demonstrate compliance with standards for equal employment opportunity established by state and federal statute.

City Council of Jackson, Michigan

**CONTRACT COMPLIANCE**

**CERTIFICATION**

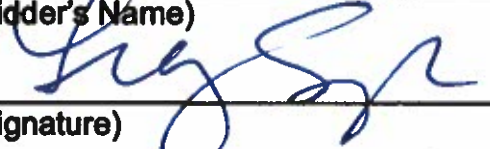
R.W. Mercer Company certifies that he/she/it will not discriminate against any employee or applicant for employment with respect to hire, tenure, term, conditions, or privileges or employment because race, religion or national origin, color, age, sex, height, weight, marital status, sexual orientation, gender identity, and physical or mental handicap.

In connection with this commitment R.W. Mercer Company understands that he/she/it name will be reviewed by the State of Michigan, Department of Civil Rights for determination of its status as an awardable Bidder.

The undersigned hereby agrees that he/she/it will abide by the terms of any agreements made with the City of Jackson in order to achieve awardable status.

Dated: 1/9/2023

By: R.W. Mercer Company  
(Bidder's Name)

By:   
(Signature)

By: Tracy Saylor, Vice President  
(Title)

2322 Brooklyn Road  
Address

Jackson  
City

Michigan 49203  
State and Zip

## **NON-DISCRIMINATION CLAUSE FOR ALL CITY OF JACKSON CONTRACTS**

In connection with the performance of this contract, the contractor agrees as follows:

1. The contractor will not discriminate against any employee/employer for employment because of race, religion or national origin, color, age, sex, height, weight, marital status, sexual orientation, gender identity, and physical or mental handicap. The contractor will take affirmative action to ensure that minority applicants are employed, and that employees are treated during employment without regard to their race, religion, color, national origin, age, sex, height, weight, marital status or handicap. Such action shall include, but not be limited to, the following: layoff or termination, rates of pay or other forms of compensation, selection for training, upgrading or promotion, transfer or recruitment.
2. The contractor will, in all solicitations or advertisements for employees placed by or on behalf of the contractor, state that all qualified applicants will receive consideration for employment without regard to race, religion, color, national origin, age, sex, height, weight, marital status or handicap. As a disclaimer, the contractor may state in the advertisement that he/she is an equal opportunity employer.
3. The contractor will furnish and file compliance reports with the City of Jackson as requested. Such reports shall elicit information as to the practices, policies, program and employment statistics for the contractor and said contractor shall permit access to all books, records and accounts regarding employment practices by agents and representatives of the City duly charged with investigative duties to assure compliance with this clause.
4. Breach of the covenants herein may be regarded as a material breach of the contract, or purchasing agreement.
5. The contractor will include, or incorporate by reference, the provisions of paragraphs (1) through (4) in every subcontract or purchase order unless exempted by the rules, regulations or orders of the Michigan Civil Rights Commission and will provide in every subcontract or purchase order that said provisions will be binding upon each subcontractor or seller.

**EQUAL EMPLOYMENT OPPORTUNITY CERTIFICATION**

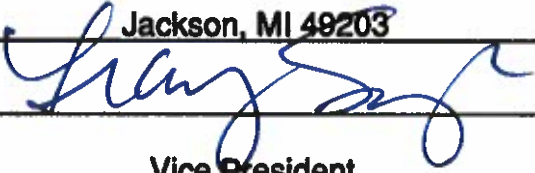
The undersigned understands and agrees that, as a Contractor for services, there shall be no discrimination against any employee or applicant for employment because of race, religion or national origin, color, age, sex, height, weight, marital status, sexual orientation, gender identity, and physical or mental handicap, including but no limited to employment, upgrading, demotion, or transfer; recruitment or recruitment advertising; layoff or termination; rates of pay or other forms of compensation and selection for training.

The Contractor further agrees to the following:

- (a) It will assist and actively cooperate with the City in obtaining compliance of any subcontractors with the equal opportunity rules, regulations, and relevant orders.
- (2) It will furnish the City such information as might be required for the supervision of its compliance program, and will otherwise assist the City in the discharge of its responsibility for ensuring compliance.
- (3) In the event that the Contractor fails or refuses to comply with the equal opportunity regulations, the City may cause to be canceled, terminated, or suspended in whole or in part the contractual arrangement between the City and the Contractor.

NAME OF BIDDER: R.W. Mercer Company

ADDRESS: 2322 Brooklyn Road  
Jackson, MI 49203

SIGNED BY: 

TITLE: Vice President

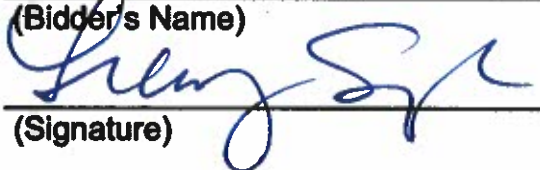
DATE: 1/10/2023

**CERTIFICATION OF NONSEGREGATED FACILITIES**

The bidder certifies that he does not maintain or provide for his employees any segregated facilities and do not permit his employees to perform their services at any location, under his control, where segregated facilities are maintained. The bidder certifies further that he will not maintain or provide for his employees any segregated facilities at any of his establishments, and that he will not permit his employees to perform their services at any location under his control where segregated facilities are maintained. The bidder agrees that a breach of this certification will be a violation of the Equal Opportunity clause in any contract resulting from acceptance of this bid. As used in this certification, the term "segregated facilities" means any waiting rooms, work areas, restrooms and washrooms, restaurants and other eating areas, time clocks, locker rooms and other storage or dressing areas, parking lots, drinking fountains, recreation or entertainment areas, transportation, and housing facilities provided for employees which are segregated by explicit directive or are in fact segregated on the basis of race, color, religion, or national origin, because of habit, local custom, or otherwise. The bidder agrees that (except where he has obtained identical certification from proposed subcontractors for specific time periods) he will obtain identical certification from proposed subcontractors prior to the award of subcontracts exceeding \$10,000 which are not exempt from the provisions of the Equal Opportunity clause, and that he will retain such certifications in his files.

Dated: 1/10/2023

By: Tracy Saylor  
(Bidder's Name)

By:   
(Signature)

By: Vice President  
(Title)

2322 Brooklyn Road  
Address

Jackson  
City

Michigan 49203  
State and Zip





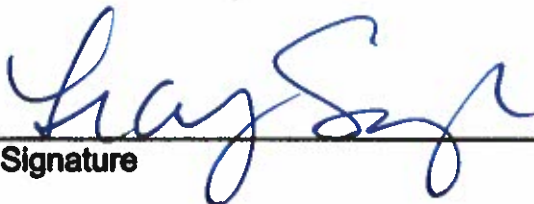
**RIGHT TO KNOW  
CONTRACTOR RELEASE FORM**

I, Tracy Saylor an authorized representative of R.W. Mercer Company am aware that as a requirement to perform work for the City of Jackson on a contractual basis, I must have provided my employees with the basic training requirements of the HAZARD COMMUNICATION STANDARD as prescribed by the Michigan Right to Know amendments to Act 154 of the Public Acts of 1974 (Act 80, Public Acts 1986), prior to starting any work for the City. While engaged in working for the City, I will continue to comply with Michigan Right to Know Law until completion of the contract.

I am aware that if I bring any hazardous chemical to the City's work place, I must have available the MSDS for these chemicals, in a place accessible to all employees in the work place. If necessary, due to the "special protection information" requirement stated on the MSDS for the chemicals, I will provide all employees with any special training, special protective clothing or equipment necessary to eliminate or lessen the possible exposure to the hazardous chemical or chemicals.

By execution of this Release, the contractor acknowledges that he and all subcontractors and suppliers, will comply with all requirements of the HAZARD COMMUNICATION STANDARD. Further, the contractor shall hold harmless from and indemnify the City against all claims, suits, actions, costs, counsel fees, expenses, damages, judgements or decrees, by reason of his failure, or the failure of any subcontractor, suppliers, or any person employed under said contractor to comply with the requirements of Act 154 of the Public Acts of 1974 as amended.

Dated 1/10/2023

  
Signature



## City of Jackson Ethics Disclosure Form Vendors and Contractors

Name <p style="text-align: center;">Tracy Saylor</p>	Company <p style="text-align: center;">R.W. Mercer Company</p>
Telephone <p style="text-align: center;">(517) 787-2960</p>	Email Address <p style="text-align: center;">tracy@rwmerc.com</p>

Contract or matter pending with the City:

---



---

I, Tracy Saylor, being duly sworn, and pursuant to City of Jackson Ordinance No. 2015-18, I hereby disclose and swear to the following (check all that apply and provide details below):

- I, or my company's owners, members, major shareholders, or corporate officers, have a financial interest in a contract or matter pending before Jackson City Council.
- A relative<sup>1</sup> or immediate family member<sup>2</sup> of myself or my company's owners, members, major shareholders, or corporate officers has a financial interest in a contract or matter pending before a City office, department, board, or commission.
- I, or my company's owners, members, major shareholders, or corporate officers, have an interest in real or personal property that is subject to a decision by the City regarding the purchase, sale, lease, zoning, property improvements, NOORPR or FVA registration, a development agreement, or a special tax designation or abatement.

Property address: \_\_\_\_\_

Property interest: \_\_\_\_\_

- An immediate family member or relative of myself or my company's owners, members, major shareholders, or corporate officers, has a financial interest in real or personal property that is subject to a decision by the City regarding the purchase, sale, lease, zoning, property improvements, NOORPR or FVA registration, a development agreement, or a special tax designation or abatement.

<sup>1</sup> Relative means any spouse, domestic partner, great grandparents, step great grandparents, grandparents, step grandparents, sons, stepsons, daughters, step daughters, grandsons, step grandsons, granddaughters, step granddaughters, brothers, step brothers, sisters, step sisters, and in-laws of a Public Employee, the Mayor, an Elected Official, an Appointed Official, a member of a Board or Commission, a Contractor, or an Advisor of the City.

<sup>2</sup> Immediate family member means a Public Employee, the Mayor, an Elected Official, an Appointed Official, a member of a Board or Commission, a Contractor, or an Advisor's spouse, domestic partner, individual who lives in the Public Employee's household or an individual claimed by a Public Employee or a Public Employee's spouse as a dependent under the United States Internal Revenue Code at 26 USC 1, et seq.

Property address: \_\_\_\_\_

Property interest: \_\_\_\_\_

An immediate family member or relative of myself or my company's owners, members, major shareholders, or corporate officers, is employed by the City or making an application for employment to the City.

Relative name: \_\_\_\_\_

City Department: \_\_\_\_\_

I, or my company's owners, members, major shareholders, or corporate officers, have made campaign contributions in the last year to a candidate running for elective office with the City.

Name of Candidate: \_\_\_\_\_

Amount of Campaign Contribution: \_\_\_\_\_

The following entities and persons have a financial interest in the contract or matter identified above:

\_\_\_\_\_  
\_\_\_\_\_  
\_\_\_\_\_

Additional information regarding any of the above:

\_\_\_\_\_  
\_\_\_\_\_  
\_\_\_\_\_

None of the above apply.

Dated:

  
\_\_\_\_\_  
Signature

STATE OF MICHIGAN     )  
                                  ) SS  
COUNTY OF JACKSON    )

The foregoing instrument was acknowledged before me this 9th day of January, 2023.

By Debra Ann Ehrig  
Debra Ann Ehrig  
Comm Expires: 3-14-23



## Responsible Contractor Ordinance

Below are twenty-nine (29) Responsibility Criteria that must be answered per the City's Responsible Contractor Ordinance. For each criterion provide a relevant response or attachments as required.

**Answers to these criteria will not exclude any bidder from the bid process or ultimate award.**

<b>CRITERIA 1:</b>	
COMPANY NAME:	R.W. Mercer Company
ADDRESS:	2322 Brooklyn Road
CITY, STATE, ZIP:	Jackson, MI 49203
TELEPHONE:	(517) 787-2960
OFFICERS:	
President: Andy Mercer	Email Address: andy@rwmercerc.com
Vice President: Tracy Saylor	Email Address: tracy@rwmercerc.com
Secretary: Tobin Dunigan	Email Address: tdunigan@rwmercerc.com
Treasurer: Mike Schilling	Email Address: mschilling@rwmercerc.com
<b>CRITERIA 2:</b>	
How many years has your organization been in business under your present firm name? 46+	
PARENT COMPANY NAME:	N/A
STREET ADDRESS:	N/A
CITY, STATE, ZIP CODE:	N/A
UNDER CURRENT MANAGEMENT SINCE (DATE):	N/A

### RESPONSIBLE CONTRACTOR ORDINANCE

**CRITERIA 3:**

**State and local licenses and license numbers held by your organization:**

Residential Contractor's License 2102177902

**What are your formal training programs: a) apprentice/journeyman, b) other comparable formal training programs?**

Electrical apprentice program - petroleum construction  
Manufacturer training/certification - various  
OSHA; CPR/First Aid, etc - yearly training

**CRITERIA 4:**

**Confirmation that all subcontractors, employees and other individuals working on the construction project will maintain current applicable licenses required by law for all licensed occupations and professions.**

Confirmed

**CRITERIA 5:**

**Verification that the bidder is in compliance with all applicable state and federal laws and visa requirements regarding the hiring of non-US citizens, and disclosure of any work visas sought or obtained by the bidder, any of the bidder's subcontractors, or any of the bidder's employees or independent contractors, in order to perform any portion of the project.**

Confirmed

**RESPONSIBLE CONTRACTOR ORDINANCE**

**CRITERIA 6 (ATTACHMENT REQUIRED)**

Attach evidence of experience with construction techniques, trade standards, quality workmanship, project scheduling, cost control, management of projects of comparable size/complexity, and building codes by documenting the bidder's ability and capacity to perform the project. The bidder must identify those portions of the project it reasonably believes will be subcontracted and the names of the subcontractors.

**CRITERIA 7 (ATTACHMENT REQUIRED)**

Evidence of bonding capacity within the past twelve (12) months, that the applicant has financial resources to start up and follow through on the project(s) and to respond to damages in case of default as shown by written verification of bonding capacity equal to or exceeding the amount of the bidder's scope of work on the project. The written verification must be submitted by a licensed surety company rated "B+" (or better) in the current A.M. Best Guide and qualified to do business within the State of Michigan.

**CRITERIA 8:**

A list of all litigation and arbitrations currently pending and within the past five (5) years, including an explanation of each (parties, court/forum, legal claims, damages sought, and resolution).

NONE

**CRITERIA 9:**

Disclosure of any violations of state, federal or local laws or regulations, including OSHA or MIOSHA violations, state or federal prevailing wage laws, wage and hour laws, worker's compensation or unemployment compensation laws, rules or regulations, issued to or against the bidder within the past five years.

NONE

Please refer to attached.

**RESPONSIBLE CONTRACTOR ORDINANCE**

**Criteria #6 – Evidence of Experience**

In the last three years, we have completed two large general contracting projects for the City of Jackson, including the Department of Public Works and Martin Luther King Center. We also completed the construction of The 200 Apartment Complex in downtown Jackson last year.



Surety Bonding & Insurance Group  
5100 Birch Point Dr.  
Interlochen, MI 49643

Phone: 231-276-3201  
Mobil: 517-256-2597  
sigkurowski@msn.com

---

January 28, 2022

To Whom It May Concern:

Re: R. W. Mercer Company

For the past 18 years, our agency, along with Nationwide Mutual Insurance Company (Best Rating A+, U.S. Treasury rating: \$1 Billion+) have provided surety bonds for the captioned. Over the years, R.W. Mercer Company has distinguished itself as one of the premier contractors in the State of Michigan. They consistently perform large scale construction projects, on time and within budget. Their surety company has never been asked to respond to a single complaint on any of their jobs.

During the last number of years, we have provided surety bonds in excess of \$15,000,000/ \$25,000,000 to the captioned. Subject to normal underwriting considerations, this letter shall offer you our assurances of bonding support along these lines. Should you need additional information, please free to call the undersigned.

Sincerely,

James S. Kurowski  
President and Attorney in fact



**We help build contractors**

Power of Attorney

KNOW ALL MEN BY THESE PRESENTS THAT:

Nationwide Mutual Insurance Company, an Ohio corporation

hereinafter referred to severally as the "Company" and collectively as "the Companies" does hereby make, constitute and appoint:
GAIL A KUROWSKI; JAMES S KUROWSKI

each in their individual capacity, its true and lawful attorney-in-fact, with full power and authority to sign, seal, and execute on its behalf any and all bonds and undertakings, and other obligatory instruments of similar nature, in penalties not exceeding the sum of

UNLIMITED

and to bind the Company thereby, as fully and to the same extent as if such instruments were signed by the duly authorized officers of the Company; and all acts of said Attorney pursuant to the authority given are hereby ratified and confirmed.

This power of attorney is made and executed pursuant to and by authority of the following resolution duly adopted by the board of directors of the Company:

"RESOLVED, that the president, or any vice president be, and each hereby is, authorized and empowered to appoint attorneys-in-fact of the Company, and to authorize them to execute and deliver on behalf of the Company any and all bonds, forms, applications, memorandums, undertakings, recognizances, transfers, contracts of indemnity, policies, contracts guaranteeing the fidelity of persons holding positions of public or private trust, and other writings obligatory in nature that the business of the Company may require; and to modify or revoke, with or without cause, any such appointment or authority; provided, however, that the authority granted hereby shall in no way limit the authority of other duly authorized agents to sign and countersign any of said documents on behalf of the Company."

"RESOLVED FURTHER, that such attorneys-in-fact shall have full power and authority to execute and deliver any and all such documents and to bind the Company subject to the terms and limitations of the power of attorney issued to them, and to affix the seal of the Company thereto; provided, however, that said seal shall not be necessary for the validity of any such documents."

This power of attorney is signed and sealed under and by the following bylaws duly adopted by the board of directors of the Company.

Execution of Instruments. Any vice president, any assistant secretary or any assistant treasurer shall have the power and authority to sign or attest all approved documents, instruments, contracts, or other papers in connection with the operation of the business of the company in addition to the chairman of the board, the chief executive officer, president, treasurer or secretary; provided, however, the signature of any of them may be printed, engraved, or stamped on any approved document, contract, instrument, or other papers of the Company.

IN WITNESS WHEREOF, the Company has caused this instrument to be sealed and duly attested by the signature of its officer the 20th day of August, 2021.

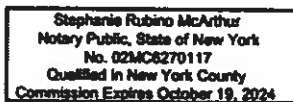
[Handwritten signature of Antonio C. Albanese]

Antonio C. Albanese, Vice President of Nationwide Mutual Insurance Company

ACKNOWLEDGMENT

STATE OF NEW YORK COUNTY OF NEW YORK: ss

On this 20th day of August, 2021, before me came the above-named officer for the Company aforesaid, to me personally known to be the officer described in and who executed the preceding instrument, and he acknowledged the execution of the same, and being by me duly sworn, deposes and says, that he is the officer of the Company aforesaid, that the seal affixed hereto is the corporate seal of said Company, and the said corporate seal and his signature were duly affixed and subscribed to said instrument by the authority and direction of said Company.



[Handwritten signature of Stephanie Rubino McArthur]

Notary Public
My Commission Expires
October 19, 2024

CERTIFICATE

I, Laura B. Guy, Assistant Secretary of the Company, do hereby certify that the foregoing is a full, true and correct copy of the original power of attorney issued by the Company; that the resolution included therein is a true and correct transcript from the minutes of the meetings of the boards of directors and the same has not been revoked or amended in any manner; that said Antonio C. Albanese was on the date of the execution of the foregoing power of attorney the duly elected officer of the Company, and the corporate seal and his signature as officer were duly affixed and subscribed to the said instrument by the authority of said board of directors; and the foregoing power of attorney is still in full force and effect.

IN WITNESS WHEREOF, I have hereunto subscribed my name as Assistant Secretary, and affixed the corporate seal of said Company this 28th day of January, 2022.

[Handwritten signature of Laura B. Guy]

Assistant Secretary

**MIOSHA/OSHA Citations - Criteria #2**

Date	Job Location	Department	Violation Description/Classification	Penalty Amount	Corrective Action Taken
2017					
5/16/2017	Napoleon, MI	General Contracting	Aerial Work Platforms Fall protection Fixed and portable ladders Electrical installations (cords)	\$1,500 \$1,500 \$0 \$0	Abated on site Abated on site Corrected during inspection Corrected during inspection
5/18/2017	Vienna, OH	Petroleum Construction	No safety data sheets on site	\$0	Corrected during inspection
2018	None				
2019	None				
2020					
7/20/2020	Marshall, MI	General Contracting	No guard on portable grinder  Workers exposed to material hazard of materials being attached to guardrail of Aerial Work Platform	\$1,000  \$0	Corrected during inspection  Corrected during inspection
2021					
11/16/2021	Howell, MI	Petroleum Construction	Mini Excavator Annual Inspection Not on site	\$0	Zero fee citation; abated

**CRITERIA 10:**

Disclosure of any debarment by any federal, state or local governmental unit and/or findings of non-responsibility or non-compliance with respect to any public or private construction project performed by the bidder.

NONE

**CRITERIA 11:**

Proof of insurance, including certificates of insurance, confirming existence and amount of coverage for liability, property damage, workers compensation, and any other insurances required by the proposed contract documents.

Name: Please refer to attached; Insurance renewal in progress.

Walton Insurance Group

Type of Coverage:

General Liability, Auto, Worker's Comp

Telephone:

(517) 787 - 2600

Are you self-insured for Worker's Compensation Insurance? Yes \_\_\_\_\_ No

**CRITERIA 12 (ATTACHMENT REQUIRED):**

A statement regarding the bidder's staffing capabilities and labor sources including subcontractors and a verification from the bidder that construction workers will not be misclassified as independent contractors in violation of state or federal law.

R.W. Mercer Co.'s workers are not classified as independent contractors. Any subcontracting firms employed by Mercer are considered independent contractors. Subcontractors are required by contract to comply with all federal, state and local laws with regard to its employees.

**RESPONSIBLE CONTRACTOR ORDINANCE**



# CERTIFICATE OF LIABILITY INSURANCE

DATE (MM/DD/YYYY)

3/23/2022

THIS CERTIFICATE IS ISSUED AS A MATTER OF INFORMATION ONLY AND CONFERS NO RIGHTS UPON THE CERTIFICATE HOLDER. THIS CERTIFICATE DOES NOT AFFIRMATIVELY OR NEGATIVELY AMEND, EXTEND OR ALTER THE COVERAGE AFFORDED BY THE POLICIES BELOW. THIS CERTIFICATE OF INSURANCE DOES NOT CONSTITUTE A CONTRACT BETWEEN THE ISSUING INSURER(S), AUTHORIZED REPRESENTATIVE OR PRODUCER, AND THE CERTIFICATE HOLDER.

**IMPORTANT:** If the certificate holder is an ADDITIONAL INSURED, the policy(ies) must be endorsed. If SUBROGATION IS WAIVED, subject to the terms and conditions of the policy, certain policies may require an endorsement. A statement on this certificate does not confer rights to the certificate holder in lieu of such endorsement(s).

<b>PRODUCER</b> Walton Insurance Group 2929 Spring Arbor Rd. P.O. Box 3029 Jackson MI 49204	<b>CONTACT NAME:</b> Kathy Corden <b>PHONE (AG. No. Ext.):</b> (517) 787-2600 <b>FAX (AG. No.):</b> (517) 787-3857 <b>E-MAIL ADDRESS:</b> kcorden@waltoninsurancegroup.com	
	<b>INSURER(S) AFFORDING COVERAGE</b>	
<b>INSURED</b> R.W. Mercer Co. 2322 Brooklyn Road PO Box 180 Jackson MI 49204-0180	<b>INSURER A:</b> EMCASCO Insurance Co <b>NAIC #</b> 21407	
	<b>INSURER B:</b> Employers Mutual Casualty Company <b>21415</b>	
	<b>INSURER C:</b> Safety National Casualty Corp <b>15105</b>	
	<b>INSURER D:</b> Crum & Forster Speciality Insurance Co <b>44520</b>	
	<b>INSURER E:</b>	
	<b>INSURER F:</b>	

**COVERAGES**      **CERTIFICATE NUMBER:** CL2232324362      **REVISION NUMBER:**

THIS IS TO CERTIFY THAT THE POLICIES OF INSURANCE LISTED BELOW HAVE BEEN ISSUED TO THE INSURED NAMED ABOVE FOR THE POLICY PERIOD INDICATED. NOTWITHSTANDING ANY REQUIREMENT, TERM OR CONDITION OF ANY CONTRACT OR OTHER DOCUMENT WITH RESPECT TO WHICH THIS CERTIFICATE MAY BE ISSUED OR MAY PERTAIN, THE INSURANCE AFFORDED BY THE POLICIES DESCRIBED HEREIN IS SUBJECT TO ALL THE TERMS, EXCLUSIONS AND CONDITIONS OF SUCH POLICIES. LIMITS SHOWN MAY HAVE BEEN REDUCED BY PAID CLAIMS.

INSR LTR	TYPE OF INSURANCE	ADDL INSD	INSUR WVD	POLICY NUMBER	POLICY EFF (MM/DD/YYYY)	POLICY EXP (MM/DD/YYYY)	LIMITS
A	<input checked="" type="checkbox"/> COMMERCIAL GENERAL LIABILITY			3X42633	8/1/2021	8/1/2022	EACH OCCURRENCE \$ 1,000,000
	<input type="checkbox"/> CLAIMS-MADE <input checked="" type="checkbox"/> OCCUR						DAMAGE TO RENTED PREMISES (Ea occurrence) \$ 500,000
	<input checked="" type="checkbox"/> Contractual Liability						MED EXP (Any one person) \$ 10,000
	<input checked="" type="checkbox"/> X C U Included						PERSONAL & ADV INJURY \$ 1,000,000
	GEN'L AGGREGATE LIMIT APPLIES PER:						GENERAL AGGREGATE \$ 2,000,000
	<input type="checkbox"/> POLICY <input checked="" type="checkbox"/> PRO-JECT <input type="checkbox"/> LOC						PRODUCTS - COMPROP AGG \$ 2,000,000
	OTHER:						\$
A	AUTOMOBILE LIABILITY			3E42633	8/1/2021	8/1/2022	COMBINED SINGLE LIMIT (Ea accident) \$ 1,000,000
	<input checked="" type="checkbox"/> ANY AUTO						BODILY INJURY (Per person) \$
	<input type="checkbox"/> ALL OWNED AUTOS	<input type="checkbox"/> SCHEDULED AUTOS					BODILY INJURY (Per accident) \$
	<input checked="" type="checkbox"/> HIRED AUTOS	<input checked="" type="checkbox"/> NON-OWNED AUTOS					PROPERTY DAMAGE (Per accident) \$
							\$
B	<input checked="" type="checkbox"/> UMBRELLA LIAB <input checked="" type="checkbox"/> OCCUR			3J42633	8/1/2021	8/1/2022	EACH OCCURRENCE \$ 6,000,000
	<input type="checkbox"/> EXCESS LIAB <input type="checkbox"/> CLAIMS-MADE						AGGREGATE \$ 6,000,000
	DED <input checked="" type="checkbox"/> RETENTION \$ 10,000						\$
C	WORKERS COMPENSATION AND EMPLOYERS' LIABILITY	Y/N	N/A	EMER-C	5/1/2022	5/1/2023	<input checked="" type="checkbox"/> PER STATUTE <input type="checkbox"/> OTH-ER
	ANY PROPRIETOR/PARTNER/EXECUTIVE OFFICER/MEMBER EXCLUDED? (Mandatory in NH)	<input checked="" type="checkbox"/> N					E.L. EACH ACCIDENT \$ 1,000,000
	If yes, describe under DESCRIPTION OF OPERATIONS below						E.L. DISEASE - EA EMPLOYEE \$ 1,000,000
							E.L. DISEASE - POLICY LIMIT \$ 1,000,000
D	Contractors Pollution Liab			CPL113232	8/1/2021	8/1/2022	claim limit \$3,000,000
B	Installation Floater			3C42633	8/1/2021	8/1/2022	\$500,000

DESCRIPTION OF OPERATIONS / LOCATIONS / VEHICLES (ACORD 101, Additional Remarks Schedule, may be attached if more space is required)

<b>CERTIFICATE HOLDER</b> Evidence of Coverage      Criteria #11	<b>CANCELLATION</b> SHOULD ANY OF THE ABOVE DESCRIBED POLICIES BE CANCELLED BEFORE THE EXPIRATION DATE THEREOF, NOTICE WILL BE DELIVERED IN ACCORDANCE WITH THE POLICY PROVISIONS.
	<b>AUTHORIZED REPRESENTATIVE</b> Ethan Harris/KCORD <i>Ethan G Harris</i>

© 1988-2014 ACORD CORPORATION. All rights reserved.

**CRITERIA 13:**

Verification of an existing Fitness for Duty Program (drugs and alcohol) of each employee working on the proposed jobsite.

Yes, we have a Fitness for Duty Program

No, we do not have a Fitness for Duty Program

Additional Information:

**CRITERIA 14:**

A warranty statement regarding labor, equipment and materials.

Labor, material and equipment warranties should be defined in the plans and specifications for the project.

**CRITERIA 15:**

A statement affirming that the firm will pay all craft employees that it employs on the project the current wage rates and fringe benefits as required under applicable federal, state, or local wage laws.

Confirmed; provided the project we are bidding on specifies that it is a prevailing wage project and the applicable wage rates to be paid on that project are provided by the City.

**RESPONSIBLE CONTRACTOR ORDINANCE**

**CRITERIA 16:**

A statement from the contractor or subcontractor acknowledging their obligation to comply with this Ordinance in each contract and subcontract.

Acknowledged

**CRITERIA 17:**

A statement identifying what possible change orders could be necessary and what their approximate subsequent total costs would be.

It is not possible to determine at this time what change orders would be necessary for a project that is not under contract.

**CRITERIA 18:**

Qualifications of management and supervisory personnel to be assigned by the bidder.

Please refer to attached.

**Criteria #18 – Qualifications of Management and Supervisory Personnel**

All of our project managers have over 20-30 years of experience in the industry, with the majority of them also holding a B.S. in Construction Management from Michigan State University. The City's Building Department can attest to the quality of our management and supervisory personnel.

**CRITERIA 19 (ATTACHMENT REQUIRED):** Please see attachment to Criteria 18

References from individuals or entities the bidder has worked for within the last five (5) years including information regarding records of performance and job site cooperation.

**CRITERIA 20:**

Evidence of any quality assurance program used by the bidder and the results of any such program on the bidder's previous projects.

N/A

**CRITERIA 21:**

Assurance that all construction work for this project must proceed economically, efficiently, continuously and without interruption.

Confirmed

**CRITERIA 22 (ATTACHMENT REQUIRED):**

A list of projects completed within the past five (5) years of comparable size/complexity, including dates, clients, approximately dollar value, and size. Documentation from these previous projects including but not limited to all extra costs relating to the bidder's timeliness, performance, quality of work, extension requests, contractual fines and penalties imposed, liens filed, history of claims for extra work and any contract defaults with an explanation of the reason for the default and how the default was resolved.

**RESPONSIBLE CONTRACTOR ORDINANCE**

**PAGE 7 OF 13 – THIS DOCUMENT MUST BE SUBMITTED WITH YOUR BID**

CONTRACTOR NAME R.W. Mercer Company

**Criteria #22**

Below is a *partial* list of general construction/construction management/design/build projects currently under construction and completed (by volume).

<b>Project</b>	<b>Description</b>	<b>Contract Amount</b>	<b>Completion Date</b>
Jackson College, Jackson, MI	Construction Manager for the renovation of Whiting Hall and construction of new building addition; LEED Silver project	\$21,900,000	05/11
Jackson Public Schools Jackson, MI	Construction Manager for the JPS 2009 Bond Campaign	\$16,000,000	05/13
Jackson County ISD Jackson, MI	Construction Manager for the Renovations To Frost Elementary School	\$16,000,000	2023
Jackson College Jackson, MI	Construction Manager for the renovation of Bert Walker Hall	\$15,000,000	08/16
Napoleon Community Schools, Napoleon, MI	Construction Manager for 2012 bond campaign to renovate high school	\$13,000,000	09/14
The 200 Jackson, MI	Construction Manager for the construction of a new apartment complex in downtown Jackson.	\$11,800,000	10/20
Omnisource – Michigan Division, Jackson, MI	Construction Manager for new shredder operation and remodeling of existing facilities	\$10,800,000	06/05
Tru by Hilton Traverse City, MI	Construction Manager for the construction of a new hotel in Traverse City	\$9,700,000	2022
Hannah Hospitality East Lansing, MI	Construction Manager for new Residence Inn in East Lansing	\$9,500,000	09/15
Consumers Energy Jackson, MI	Renovation of Jackson Innovation Center	\$8,000,000	01/16
Jackson College Jackson, MI	Construction Manager for a 24-suite student dormitory; achieved LEED Gold Certification	\$6,680,000	07/09
Lifeways (Jackson Co.) Jackson, MI	Renovation of Existing Facility	\$5,500,000	2021
Anesthesia Business Cons. Jackson, MI	Renovation of 60,000 SF facility into new Corporate headquarters	\$4,900,000	09/06
City of Jackson Jackson, MI	Construction of new public works facility	\$4,600,000	06/20
Consumers Energy Jackson, MI	Renovation of Parnall First Floor	\$4,300,000	08/18

<b>Project</b>	<b>Description</b>	<b>Contract Amount</b>	<b>Completion Date</b>
Sealandaire Jackson, MI	Renovation of 20,000 SF existing facility	\$2,800,000	08/19
Llamasoft Ann Arbor, MI	Renovation of third floor of existing facility	\$2,600,000	02/20
Jackson Free Methodist Church Jackson, MI	Construction of new addition; renovation of the existing facility	\$2,500,000	01/20
Classic Turning Jackson, MI	Construction of new addition; renovation of existing facility	\$2,400,000	10/19
Beacon & Bridge Mt. Morris, MI	Construction of new convenience store with A & W; installation of new fueling system	\$2,400,000	5/19
Standard Bistro Ann Arbor, MI	Renovation of restaurant	\$2,100,000	03/18
Turtle Creek Casino Traverse City, MI	Construction of new convenience store/ Fueling facility	\$2,000,000	07/18
Toledo 76, Inc. Homer, MI	Construction of New Convenience Store/Fueling Facility	\$1,950,000	09/15
City of Jackson Jackson, MI	Renovation and addition to existing MLK Center	\$1,910,000	10/20
MB C-Stores, LLC Dowagiac, MI	Construction of New Convenience Store/ Fueling Facility	\$1,800,000	12/13
Kelly Fuels, Inc. Jackson, MI	Construction manager for the construction of a new strip mall facility	\$1,686,000	08/17
Save Time Clark Lake, MI	Construction of new 7,700 SF convenience store; bank and Subway	\$1,600,000	05/11
Pic Center Jackson, MI	Construction of new 6,100 SF medical office facility.	\$1,550,000	06/13
Grinnell Properties, LLC Jackson, MI	Design/Build construction of new medical office facility addition	\$1,500,000	01/17
Page Ave., LLC Michigan Center, MI	Design/build construction of new two-story medical office building	\$1,500,000	02/10

**CRITERIA 23:**

The ratio of masters or journeypersons to apprentices proposed to be used on the construction project job site, if apprentices are to be used on the project.

N/A

Do you participate in the Registered Apprenticeship Programs that are registered with the United States Department of Labor Office of Apprenticeship or by a State Apprenticeship Agency recognized by the Office of Apprenticeship?

Yes

No

Additional Information:

**(ATTACHMENT REQUIRED)** Documentation of how the bidder assesses the skills and qualifications of any employees who do not have master or journeyperson certification or status, or are not participants in a Registered Apprenticeship Program.

**CRITERIA 24 (ATTACHMENT REQUIRED)**

Evidence of the bidder's worker's compensation Experience Modification Rating ("EMR"). Preference will be given to contractors and subcontractors who exhibit an EMR of 1.0 or less based on a three-year average.

**CRITERIA 25:**

All craft labor that will be employed by the firm for the project has completed at least the OSHA 10 hour training course of safety established by the U.S. Department of Labor, Occupational Safety & Health Administration. (applies to RWM personnel)

Yes

No



Criteria #24

May 11, 2022

To whom it may concern:

RE: R.W. Mercer Co.  
Workers' Compensation

The following are workers' compensation intrastate experience modification factors by policy year:

5/1/22-23	.76
5/1/21-22	.73
5/1/20-21	.73

If you have any questions, please let us know.

Sincerely,

Kathy Corden  
Account Manager

**CRITERIA 26 (ATTACHMENT REQUIRED):**

Documentation of master or journeyman certification or status for masters and journeymen to be used on the project, and the source of such certification or status N/A

**CRITERIA 27:**

A statement from the bidder as to what percentage of its workforce can be drawn significantly from area residents because a goal of the City is to utilize, in its construction activities, local residents as much as is economically feasible while retaining the high quality of construction required for its construction activities, consistent with applicable law. The City will consider in evaluating which bids best serve its interests, the extent to which responsible and qualified bidders are able to achieve this goal.

R.W. Mercer Co. will solicit local participation and utilize bids that meet the project requirements.

**CRITERIA 28 (ATTACHMENT REQUIRED):**

Evidence of Equal Employment Opportunity Programs for minorities, women, veterans, returning citizens, and small businesses. N/A

**CRITERIA 29:**

Assurance that the bidder is an equal opportunity employer and does not discriminate on the basis of race, sex, pregnancy, age, religion, national origin, marital status, sexual orientation, gender identity of expression, height, weight, or disability. **COMPANIES EQUAL EMPLOYMENT OPPORTUNITY STATEMENT:**

R.W. Mercer Co. will provide equal employment opportunities to all persons regardless of race, color, religion, sex, sexual orientation, pregnancy and gender identity, national origin, age, disability, veteran status, height, weight, marital status, familial status, arrest record, genetic information or any other basis prohibited by law. We will ensure that we maintain our commitment to reviewing all aspects of employment, including but not limited to recruitment, hiring, selection, placement, retention, promotion, termination, layoff, recall, transfer, leave of absence, compensation, and training, to identify and eliminate barriers to providing all persons equal employment opportunity

R.W. Mercer Co.; Tracy Saylor, Vice President/General Manager

**Print Firm Name/Principal**

**Signature/Principal**

7/7/2022

**Date**

**RESPONSIBLE CONTRACTOR ORDINANCE**

## Bid Evaluation Criteria.

Once the City deems a contractor a responsible bidder, having used the process identified above, the City must consider the contractor's bid. The City must consider, at minimum, each of the evaluation criteria listed in this Section in determining the best bid. The City may require contractors or subcontractors to provide additional information by inclusion in bid documents. Additionally, the list set forth below in no way limits any additional criteria that the City may deem relevant for purposes of making a determination of the best bid.

Bid documents must require any contractor or subcontractor bidding on the project to submit written responses and other information and documentation regarding the listed criteria and any other criteria specified by the City through the bid documents. The City may request additional information or explanation from any contractor or subcontractor regarding any particular criteria. The bid documents must provide that the City retains the right in its discretion to reject any and all bids. All required contractor financial and privileged information must be kept from public disclosure unless otherwise required by law.

Submitted bids must break out labor costs from material and equipment costs.

For each separate bid package, the City in its discretion will weigh the information provided by the contractor or subcontractor regarding the evaluating criteria, as a whole, to determine the best bid. Except as otherwise required by law, no single criterion will necessarily be determinative in assessing which bid is the best bid. The Purchasing Department must weigh each of the criteria based on a distribution of percentage points on a 100-point scale. Additionally, The Purchasing Department shall provide space on the bid evaluation form for the prospective bidder to include additional information about themselves and/or their bid – this section would be optional for the prospective bidder to fill out. The criteria to be considered in bid evaluation on construction projects by the City shall be weighed categorically as follows, and shall include:

### RESPONSIBLE CONTRACTOR ORDINANCE

PAGE 10 OF 13 – THIS DOCUMENT MUST BE SUBMITTED WITH YOUR BID

CONTRACTOR NAME R.W. Mercer Company

## **RESPONSIBLE CONTRACTOR BID EVALUATION CRITERIA**

Once the City deems a contractor a responsible bidder, having used the process identified above, the City must consider the contractor's bid. The City must consider, at minimum, each of the evaluation criteria listed in this Section in determining the best bid. The City may require contractors or subcontractors to provide additional information by inclusion in bid documents. Additionally, the list set forth below in no way limits any additional criteria that the City may deem relevant for purposes of making a determination of the best bid.

Bid documents must require any contractor or subcontractor bidding on the project to submit written responses and other information and documentation regarding the listed criteria and any other criteria specified by the City through the bid documents. The City may request additional information or explanation from any contractor or subcontractor regarding any particular criteria. The bid documents must provide that the City retains the right in its discretion to reject any and all bids. All required contractor financial and privileged information must be kept from public disclosure unless otherwise required by law.

Submitted bids must break out labor costs from material and equipment costs.

For each separate bid package, the City in its discretion will weigh the information provided by the contractor or subcontractor regarding the evaluating criteria, as a whole, to determine the best bid. Except as otherwise required by law, no single criterion will necessarily be determinative in assessing which bid is the best bid. The Purchasing Department must weigh each of the criteria based on a distribution of percentage points on a 100-point scale. Additionally, The Purchasing Department shall provide space on the bid evaluation form for the prospective bidder to include additional information about themselves and/or their bid – this section would be optional for the prospective bidder to fill out. The criteria to be considered in bid evaluation on construction projects by the City shall be weighed categorically as follows, and shall include:

### **Price (25%)**

1. A statement identifying what possible change orders could be necessary and what their approximate subsequent total costs would be.

<b>Submitted Bid:</b>	<b>\$86,600.00</b>
<b>Labor Costs:</b>	<b>\$34,650.00</b>
<b>Materials Costs:</b>	<b>\$43,290.00</b>
<b>Equipment Costs:</b>	<b>\$8,660.00</b>
<b>Possible Change Orders:</b>	<b>N/A</b>

### **Corporate Accountability (25%)**

1. Qualifications of management and supervisory personnel to be assigned by the bidder.
2. References from individuals or entities the bidder has worked for within the last five (5) years including information regarding records of performance and job site cooperation.
3. Evidence of any quality assurance program used by the bidder and the results of any such program on the bidder's previous projects.
4. Assurance that all construction work for this project must proceed economically, efficiently, continuously and without interruption.
5. A list of projects completed within the past five (5) years of comparable size/complexity, including dates, clients, approximate dollar value, and size. Documentation from these previous projects including but not limited to all extra costs relating to the bidder's timeliness, performance, quality of work, extension requests, contractual fines and penalties imposed, liens filed, history of claims for extra work and any contract defaults with an explanation of the reason for the default and how the default was resolved.

### **Workplace Safety (25%)**

1. The ratio of masters or journeypersons to apprentices proposed to be used on the construction project job site, if apprentices are to be used on the project.
2. Evidence of the bidder's worker's compensation Experience Modification Rating ("EMR"). Preference will be given to contractors and subcontractors who exhibit an EMR of 1.0 or less based on a three-year average.
3. All craft labor that will be employed by the firm for the project has completed at least the OSHA 10 hour training course for safety established by the U.S. Department of Labor, Occupational Safety & Health Administration.
4. Documentation of master or journeyperson certification or status for masters and journeypersons to be used on the project, and the source of such certification or status.

### **Workforce Development (15%)**

1. Documentation as to pay rates of employees and whether the bidder provides health insurance, pension or other retirement benefits, paid leave, or other benefits to its employees.
2. Documentation if the bidder participates in a Registered Apprenticeship Program that is registered with the United States Department of Labor Office of Apprenticeship or by a State Apprenticeship Agency recognized by the Office of Apprenticeship.
3. Documentation of how the bidder assesses the skills and qualifications of any employees who do not have master or journeyperson certification or status, or are not participants in a Registered Apprenticeship Program.

### **Social Equity (10%)**

1. A statement from the bidder as to what percentage of its workforce can be drawn significantly from area residents because a goal of the City is to utilize, in its construction activities, local residents as much as is economically feasible while retaining the high quality of construction required for its construction activities, consistent with applicable law. The City will consider in evaluating which bids best serve its interests, the extent to which responsible and qualified bidders are able to achieve this goal.
2. Evidence of Equal Employment Opportunity Programs for minorities, women,

**veterans, returning citizens, and small businesses.**

**3 Assurance that the bidder is an equal opportunity employer and does not discriminate on the basis of race, sex, pregnancy, age, religion, national origin, marital status, sexual orientation, gender identity or expression, height, weight, or disability.**

**MEMO TO:** Mayor and City Councilmembers

**FROM:** Jonathan Greene, City Manager

**DATE:** January 24, 2023

**SUBJECT:** Approval of Doug Jones and Chris Turner's *Community of Shapes* Art Sculpture for the MLK Boulevard and for the City Attorney and the Parks and Recreation Director to move forward with the artist agreement including delivery, installation and not to exceed \$30,000 contract.

---

**Recommendation:**

Approval of Doug Jones and Chris Turner's *Community of Shapes* Art Sculpture for the MLK Boulevard and for the City Attorney and the Parks and Recreation Director to move forward with the artist agreement including delivery, installation and not to exceed \$30,000 contract.

Attached is a memo from Kelli Hoover, Director of Parks and Recreation regarding the MLK Roundabout Art Sculpture.

We recommend approval of an art sculpture for the MLK Roundabout.

For the City Attorney and the Parks and Recreation Director to execute the appropriate documents. Your consideration and concurrence is appreciated.

JG

## DEPARTMENTAL REPORT

**MEMO TO:** Jonathan Greene, City Manager

**FROM:** Kelli Hoover, Director Parks, Recreation and Cemeteries

**DATE:** January 24, 2023

**RECOMMENDATION:** Approval of Doug Jones and Chris Turner's *Community of Shapes Art Sculpture* for the MLK Boulevard and for the City Attorney and the Parks and Recreation Director to move forward with the artist agreement including delivery, installation and not to exceed \$30,000 contract.

---

### SUMMARY

Approval of Doug Jones and Chris Turner's *Community of Shapes Art Sculpture* for the MLK Boulevard and for the City Attorney and the Parks and Recreation Director to move forward with the artist agreement including delivery, installation and not to exceed \$30,000 contract.

### BUDGETARY CONSIDERATIONS

The art sculpture purchase for \$30,000 will come from the budget line item 401-901-000-975.054.

### HISTORY, BACKGROUND and DISCUSSION

The Jackson Public Arts Commission was asked to curate an art sculpture for the MLK Roundabout in June of 2022. The Commission decided to create a subcommittee and invite commissioners from the MLK Corridor Authority, Racial Equity Commission and City Council Ward person.

The Committee was formed with Arlene Robinson City Councilperson Ward 1, Kesha Hamilton Chair of the Racial Equity Commission, George Brown Commissioner from the MLK Corridor Authority, and from the Public Arts Commission Chairperson Angela Edward and Commissioner Janet Meyer Jackman. The Committee met several times starting in July of 2022. The call for art went out nationwide in August with a due date of November 1, 2022.

The committee received 12 artist applications. Committee members reviewed each of the applications on group scoring system set up by the Jackson Public Arts Commission. The group collaborated, shared scores and narrowed down their selections to three artist. The artist were Maxwell Emcays, Ken Thompson, Doug Jones and Chris Turner. Each artist went through zoom interviews and were allowed to submit two art pieces. After this point we planned for an open house at the MLK Center on January 4, 2023.

## DISCUSSION OF THE ISSUE

The City of Jackson has presented four art sculptures after six month process by the MLK Roundabout Committee. The committee worked hard to be inclusive and transparent to reach as many citizens as they could for public comment. The Public was able to interact through social media, email and in person with each artist.

## POSITIONS

Requested action is for Council to approve Doug Jones and Chris Turner's Art Sculpture for the MLK Boulevard Roundabout and for the City Attorney and the Parks and Recreation Director to move forward with the artist agreement including delivery, installation and not to exceed \$30,000 contract.

# **Call for Art Request**



***Jackson Public Arts Commission  
Martin Luther King Jr. Blvd - Roundabout  
Sculpture***

# **Request for Proposals**

***Issue Date: August 22, 2022***  
***First Tier Submission Deadline: November 1, 2022***

## **Overview**

### **Statement of Purpose**

To commission a full size sculpture that represents the vibrant future and vitality of the City of Jackson and its Southside neighborhood, as well as the heritage of Martin Luther King Jr.'s legacy.

### **Jackson Public Arts Commission**

The Jackson Public Arts Commission is a City agency that champions the arts as essential to Jackson's quality of life. The Commission exists to build a cultural legacy, develop public arts assets and strengthen economic impact.

### **Vision statement**

The Jackson Public Arts Commission (JPAC) envisions a future where the arts, a community-wide appreciation of the arts, economic prosperity and artistic transformation go hand in hand.

### **Project Background**

Martin Luther King Jr. Blvd Roundabout Sculpture (MLKRS) is part of JPAC's Sculpture Initiative Project which will establish a collection of permanent sculptures throughout the city. The MLKRS is the fourth sculpture of this project. A MLKRS Project Committee has been formed with representatives from JPAC, Martin Luther King Corridor Improvement Authority and Racial Equity Commission.

## **1. Scope of Work**

### **Project Sculpture Outline**

**Project Budget Range:** No greater than \$30,000 includes delivery.

### **Site Location:**

Roundabout – Martin Luther King Jr. Drive (MLK) and E. Morrell Street– Jackson, Michigan

### **Specifications of Sculpture:**

Will be introduced in the second round of selection. The first round will focus on an artist's body of work and current installations (if applicable).

**Over view of location**



**South Street View of Roundabout from MLK Blvd.**



## North Street View of Roundabout from MLK Blvd.



### **Project Timeline**

MLKRS Project is a fast paced sculpture project. Project completion date of April 2023.  
*This is a two (2) tiered artist selection process.*

### **REQUEST FOR (FIRST TIER) PROPOSAL (RFP)**

**Deadline: November 1, 2022**

### **FIRST TIER:**

Artist to submit

1. A letter of interest
2. Images of artist's body work. Can be JPEG format (Minimum of three (3) separate artwork jpegs. Title, Size and Artist Name on each image), Web Link or Social Media Link.
3. Artist Resume
4. No less than two (2) recommendations from past administrators or collectors of previous installations or commissions.
5. Installation locations of previous work.
6. Overview of potential/proposed method and medium that would be used for the MLKRS Project.

MLKRS Project Committee will review all submissions and present them to the Jackson Public Arts Commissioners (JPAC) for final selection of the top three artists. Selection will be made on the above six criteria. Artists will be notified by email on results.

## **REQUEST FOR 2<sup>ND</sup> PROPOSAL- FINAL RFP**

### **SECOND TIER:**

The top three selected artists from First Tier are required to submit their Final RFP for the MLKRS Project by **December 15, 2022** with selection of artist no later than **January 15, 2023**. Contract to be issued at time of selection. Delivery and Installation no later than **April 2023**.

### **RFP Procedures**

#### **Evaluation and Award Process**

Artists are encouraged to research the history of Jackson's Southside.

Proposal of Artwork will be evaluated on the following criteria:

- **Experience** - Sculptor's previous experience in urban/community placement of artwork.
- **Impact** – Captures the expression of Jackson's vibrant future.
- **Use of color, polished materials to define sculpture.**
- **Budgetary** – The maintenance, installation, transportation and purchase price of the piece must be considered.
- **Safety** – Does the work meet safety standards?
- **Technicality** – Is the design technically feasible?
- **Creativity** – Is the design visionary and creative?  
Does the artwork capture the resilience, strength and ethics of Jackson's Southside? (See Attachment)
- **Quality** – Is the work of the highest quality?
- **Materials used:**  
JPAC discourages use of corrosive materials.

Final RFP medium for presentation may be renderings, mock up or artwork that has already been created and is ready for installation.

Three artists will present their RFP proposal either in person or via Skype to JPAC/MLKRS Project Committee. JPAC Commissioners will make the final selection of sculpture for recommendation to the Jackson City Council. Said sculpture will be presented to Jackson City Council for final approval.

#### **Process Schedule**

JPAC is seeking Final RFP by December 15, 2022 with selection of artist by January 15, 2023. Contract to be issued at time of selection. Delivery and Installation no later than April 2023.

#### **Submission Details**

**Contact:**

Kelli Hoover

JPAC Liaison - City of Jackson Parks and Recreation Director  
**City of Jackson**  
5th Floor  
161 W. Michigan Ave.  
Jackson, MI 49201  
Phone: 517-788-4040  
Email: [khoover@cityofjackson.org](mailto:khoover@cityofjackson.org)

## 2. RFP Submission Requirements

### Proposal Format

**Images:** jpg format. Label each image with artist last name, title of artwork and view side.

**Artist Cover letter and RFP:** pdf format. Include artist name, title of artwork within the header of each page.

**Cover Letter:** Summarize key elements of proposal. Let us know why you feel artwork is a good fit for the project. Acknowledge your ability to meet the paced deadlines.

**RFP to include:**

1. **List of completed projects and locations.**
2. **Experience.**
3. **Financial Capacity to complete project.**
4. **References**
  - a. Contact Name, Position
  - b. Organization
  - c. Telephone
  - d. Email
  - e. Description of the professional relationship with the reference and duration of the relationship.
5. **Understanding of Project Requirements and Approach**

### Roles and Responsibilities

The artist will be responsible for two reports to the JPAC /MLKRS Project Committee during the process of creation of artwork. Reports due dates will be determined at time of contract. Each report will contain no less than five images of artwork in current state of process: Front, Back, All Sides, Top and base, materials use update, artist comments and concerns.

If concerns arise during the process of creation, the artist is fully responsible for conveying those concerns immediately to JPAC/MLKRS representative so corrective plans can be discussed fully.

The project will be managed by JPAC/MLKRS and their selected Project Manager.

### Legal Matters\*

#### Contractual Terms and Conditions

The City of Jackson will issue and contract at the time of artist/sculpture selection. The following is a list of insurance requirements that **may be** requested by the City of Jackson, depending on sculpture selected.

general liability insurance  
workers compensation and employers liability  
automobile liability  
professional liability insurance  
property insurance

#### Payment and Penalties

List all the terms of payment for adequate performance and penalties for inadequate performance or lack of compliance.

**Payment Schedule:**

A portion of overall project budget at time of Contract Signing

A portion of overall project budget at time of finishing the artwork

Final portion of overall project budget time of delivery and installation.

If artist does not comply all funds will need to be returned to the City of Jackson.

**Termination of Agreement**

Explain your policies regarding:

- 1) Termination initiated by the issuing organization
- 2) Termination initiated by the respondent
- 3) Expiry of the agreement

**Limitations**

Do ensure that your RFP clearly sets out the limitations of the document and of your process, of your relationship to the respondent (and vice versa), matters of confidentiality etc. This section should clearly state that neither issuing an RFP nor does receiving a response constitute any form of contract or agreement with respect to the project. The limitations should also clearly state your right to cancel, amend or alter the RFP, its contents or the selection process. We strongly recommend that you consult with your board and seek the advice of a lawyer before completing this section and issuing an RFP.

- All legal matters should be reviewed by a lawyer.

## **RFP Attachment**

### **MLK Roundabout Sculpture Neighborhood Narrative**

**The City of Jackson Michigan Southside neighborhood and it's predominate population of black residents dates to the early 1900s during the northern migration of thousands from the slave-holding southern United States.**

**In search of employment opportunities, self-determination and to reestablish familial ties, these newly minted Americans began to weave the strands of black culture into a resilient community.**

**One hundred years after its inception, Jackson's Southside neighborhood has much to celebrate and a future that presents opportunity for cooperation and cohesion.**

**Still about 20 percent of the city's overall population, our Southside neighborhood has produced Tuskegee Airman, professional athletes, history-making women leaders, educators and other professionals, business owners, respected clergy, social and fraternal organizations and generations of families.**

**(Jackson was the first city in Michigan to have a black-owned bank, establishing the National Savings & Loan Bank, 417 E. Main St. in 1923)**

**To further the progress of this community, the City of Jackson has established a Martin Luther King Jr. – Corridor Improvement Authority organized to promote economic growth and development in the area by aiding in the intentional reinvestment and revitalization of property and supporting community and business opportunities within this distinct area.**

# **Maxwell Emcays**

- **Original Request for Art Application**
- **Interviewed against 12 other artist**
- **Finalist application and submission**
- **Attached emailed Public input copies**
- **Attached Open House Public input copies**

City of Jackson  
**Martin Luther King Jr. Blvd - Roundabout Sculpture**  
Statement of Interest

I am thrilled about the opportunity to use my experience in public art and cultural connection to the people of Jackson Michigan to create a work of art that echoes local heritage, uplifts, and inspires. As a Black Chicagoan, art activist and Executive Director of an art based non for profit, I understand that it is not enough to simply erect a wonderful work of art, and that is why I am excited about facilitating engagements with the community and stakeholders to truly express the heart and passion of the community through the final art piece.

Along with making meaningful artwork, I also bring a broad stroke of medium that I utilize. I have pieces in bronze, aluminum, conscious plastics, printmaking, lighting as well as digital and virtual applications. I work in a manner that looks at the intention of the work first, and the medium second. My knowledge of computer software like 3DsMax, AutoCAD, and illustrator allows me to plan ahead with intricacy, cost savings, and avoid human error. I have been able to communicate with engineers, the foundries, fabricators and the clients in a manner that ensured a clear expectation of deliverables. In addition, despite being new to bronze I have been able to reduce foundry production time by 40% through the expanded use of 3D printing, as well as push the limits of details in the model to the extent of even including fine jewelry and eyelashes in the bronze cast (which is rare). This approach has allowed me to be consistent with schedule expectations and deliver on budget.

I am confident that I can create a work of art within the budget and timeline that is innovative, heartfelt, and limitless in its potential to truly connect and engage with the City of Jackson. It is my goal to create a piece that becomes a beacon for the beautiful potential we all hold.

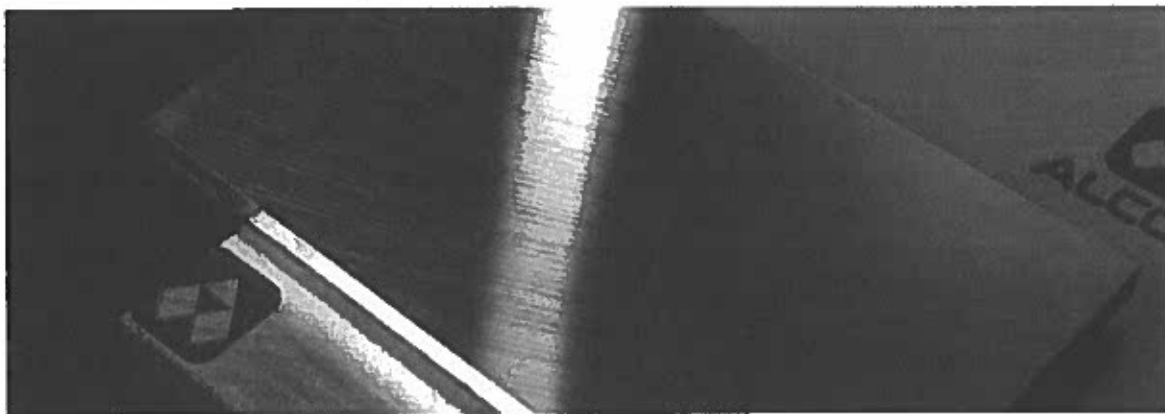
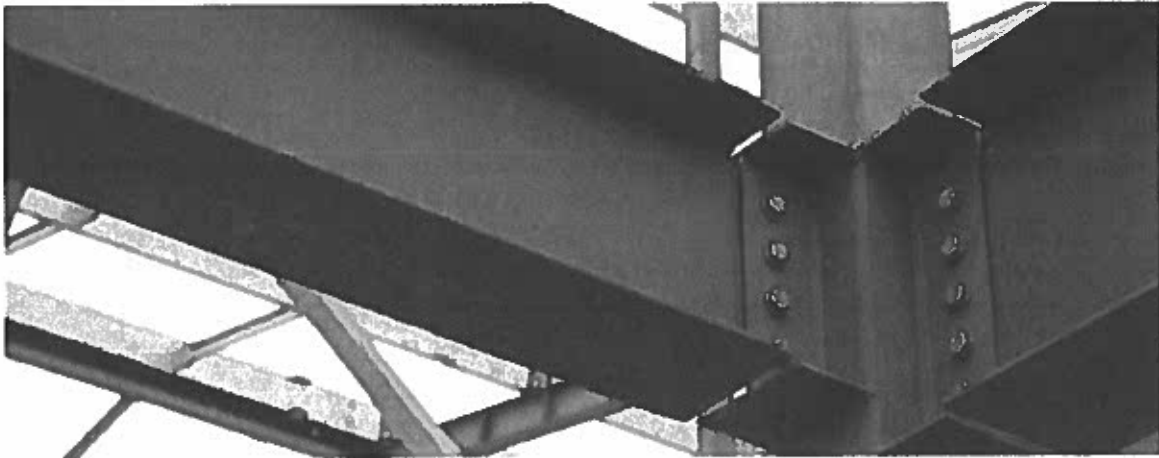
It is an honor to make this submission.

**Maxwell Emcays**

City of Jackson  
**JPAC /MLKRS Project**  
Martin Luther King Jr. Blvd - Roundabout Sculpture

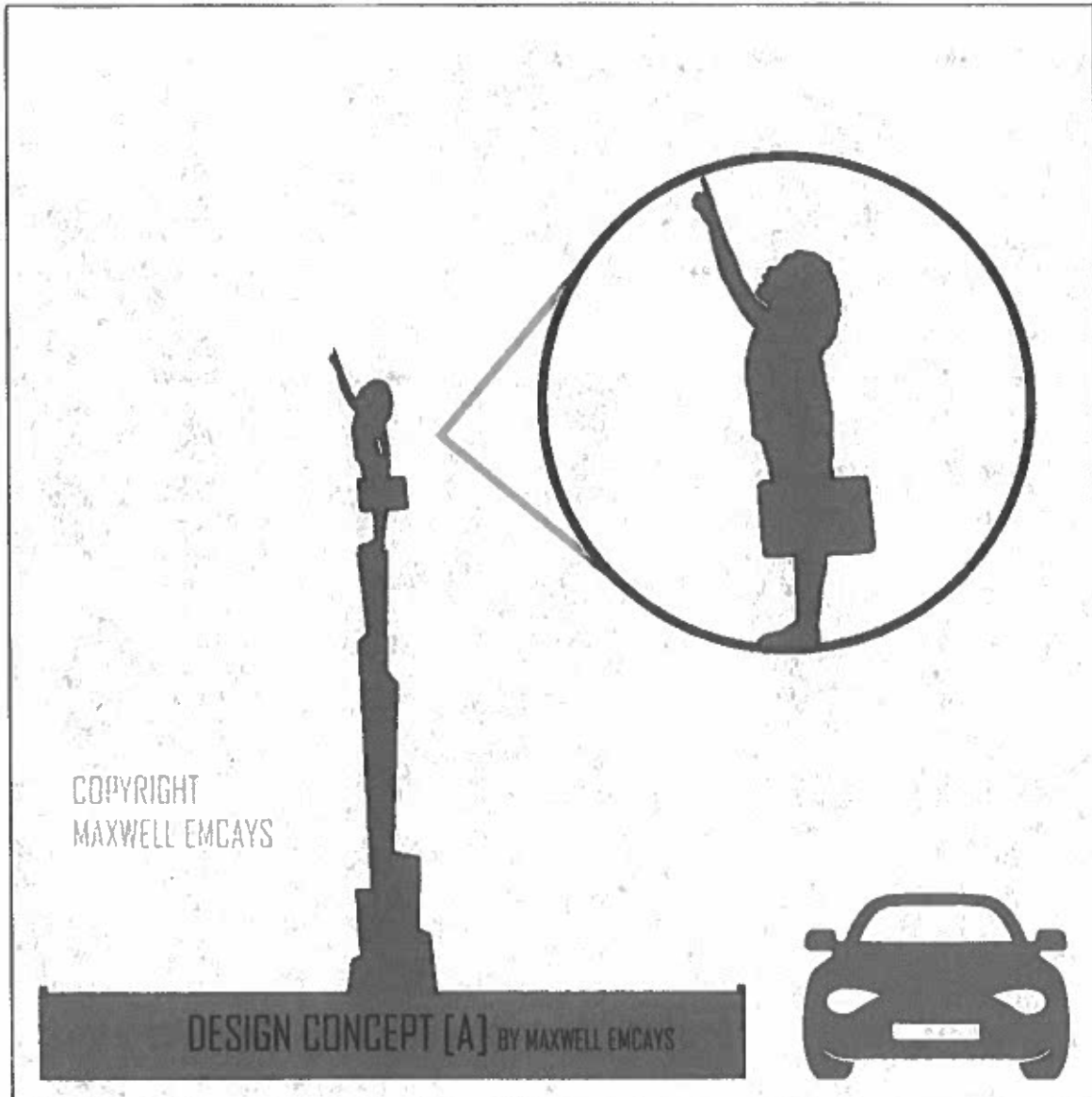
**My material and design direction considers not only the ideas and sentiment of the community but also factors allotted budget and location.**

**Material: Non-corrosive structural steel for internal support, and anodized aluminum for the primary decorative component.**



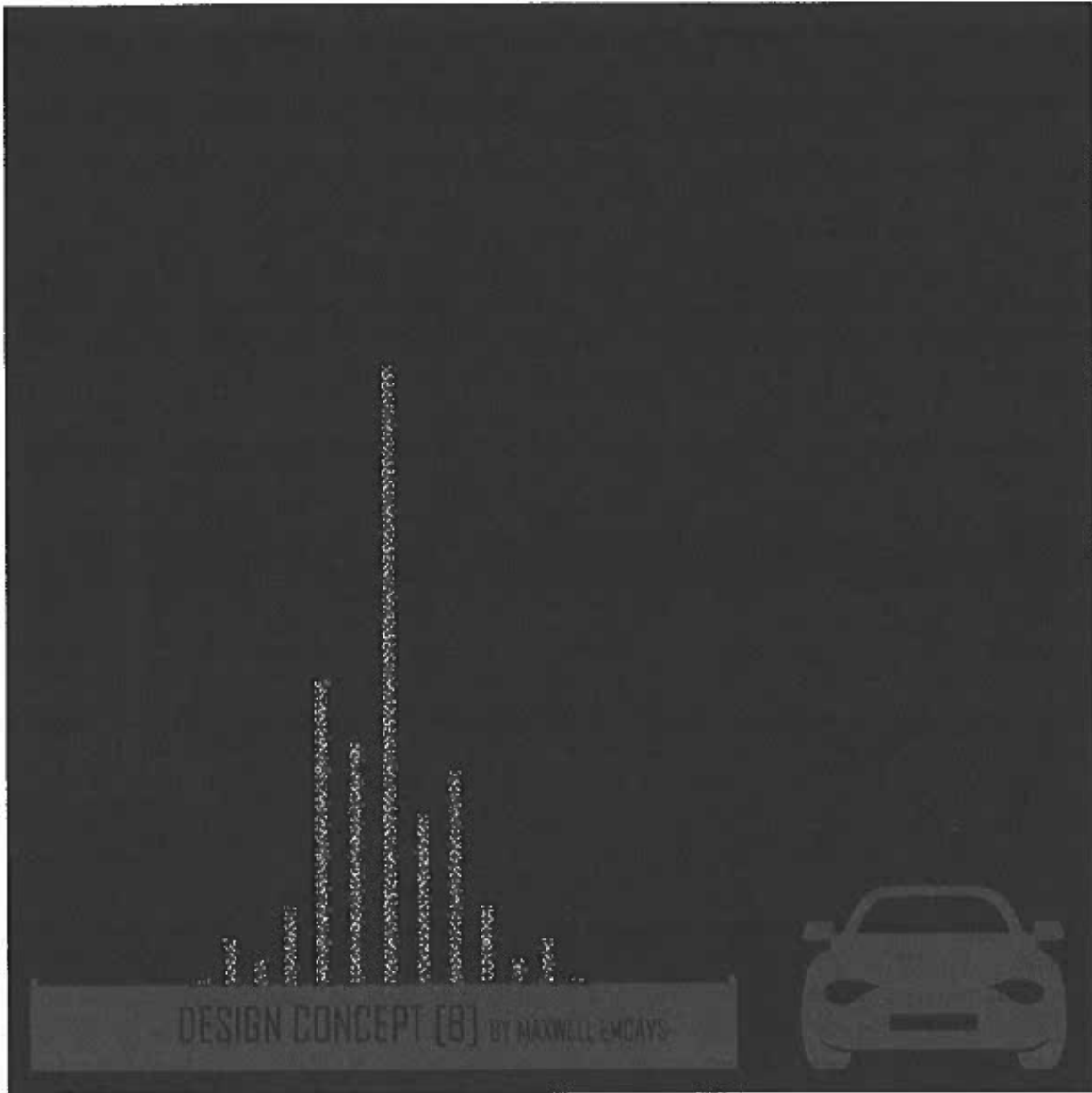
**Disclaimer: I am aware that a concept sketch was not required, however in line with providing material and the proposed method, and have supplemented illustrations. The following are drafts / initial thoughts based on the RFP. Not intended to be full concepts. I expect to conduct thorough community engagement and meetings with stakeholders to further work on concepts**

and finalization. While the budget is extremely tight, I have worked to be as imaginative as possible within those limitations.



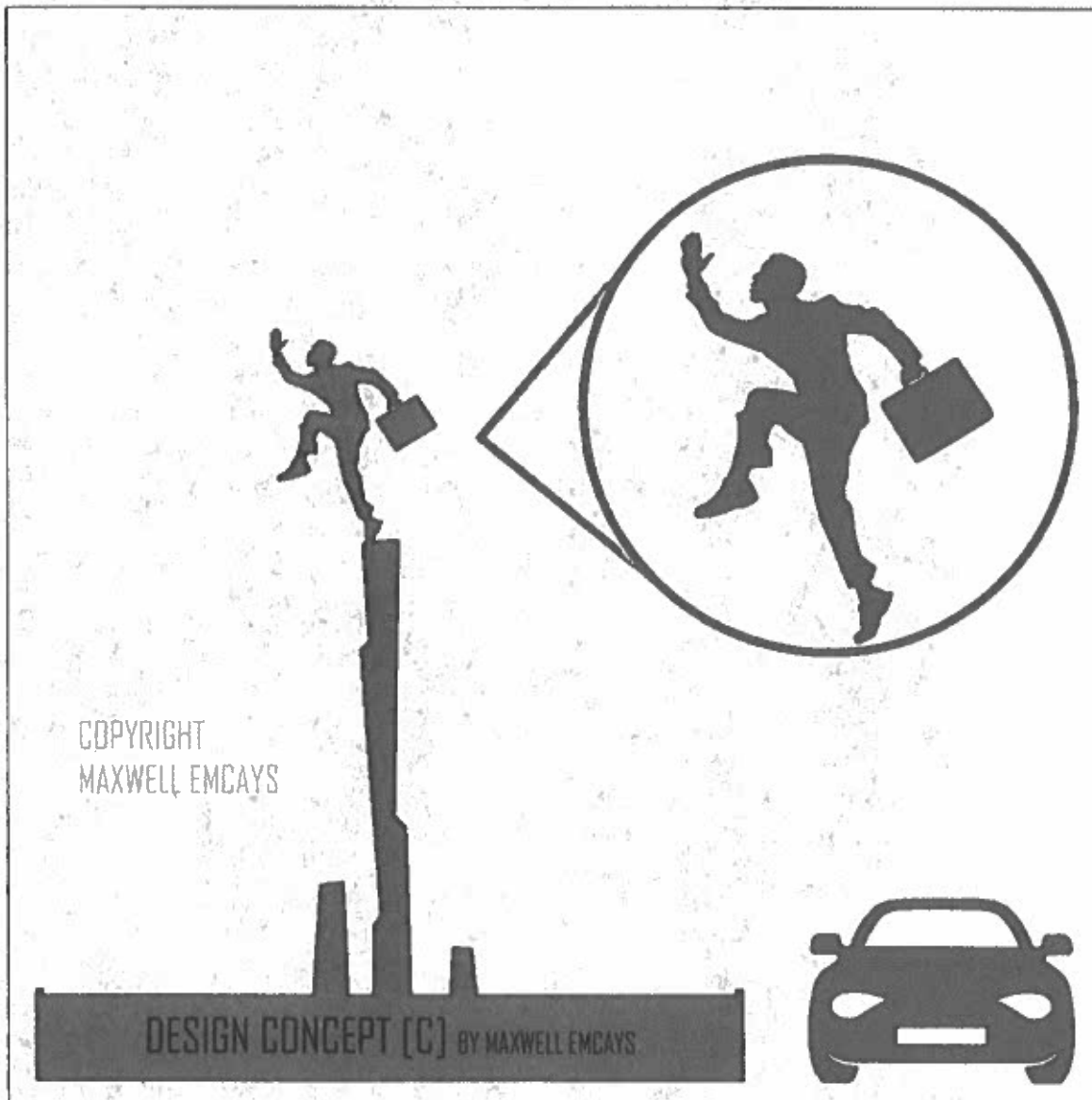
Concept A is titled "Beyond the Mountain Tops". It features a young girl looking upwards imagining and reflecting on potential. She has a briefcase that alludes to her travels and ambitions that are contingent on the progress previous generations have made. She continues the dream that Dr. Martin Luther King spoke of.

**Material / Method.** The piece will feature a cast aluminum child figure, with aluminum facade and steel structure and concrete foundation.



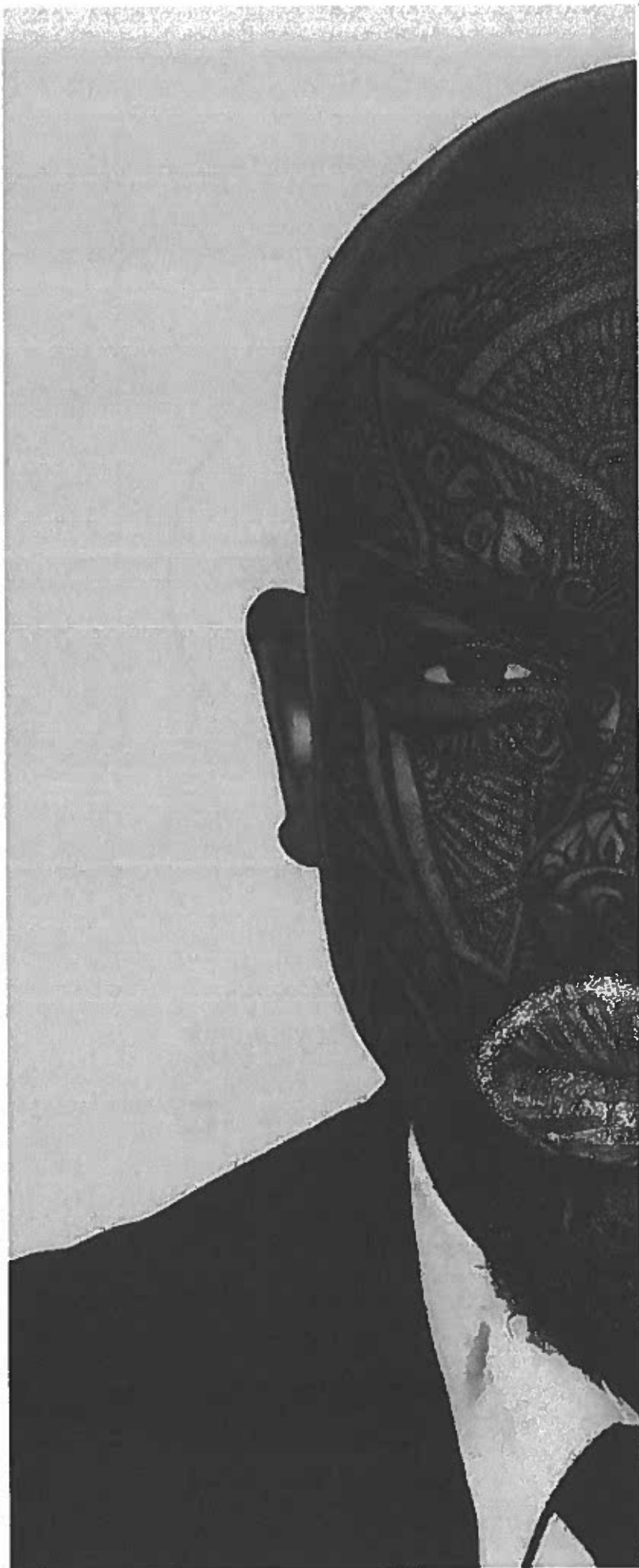
**Design B** is titled "Path to Progress". Depicted here in a night view as it would be well illuminated from the inside of the pillars. The pillars reference a graph of progress. As one can note, the pillars do not consistently increase, but rather have an "up and down" portrayal while yet progressing. This is a reminder that progress will be filled with setbacks, but yet we will reach our heights.

**Material / Method.** The piece will feature laser cut aluminum panels with steel support and concrete foundation.



**Design C is titled "Leap of faith".**

**The concept aligns again with the mountaintop mantra but portrays a leap of faith beyond the mountaintop. This echoes the many moments and ways Black people have been required to act on faith in order to progress much like those million who migrated in the 1900s to areas like Jackson Michigan.**



# MAXWELL EMCAYS

P. 312.888.0640  
E. [ari@emcays](mailto:ari@emcays)  
W. [Maxwell.Emcays.com](http://Maxwell.Emcays.com)

55 E Monroe suite 3800  
Chicago, IL  
60616

# EXHIBITIONS

**ENGLEWOOD MONUMENT SIGN**

*Chicago, IL Fall. 2022\**

**DEMAND JUSTICE**

*Chicago, IL May. 2021  
Dusable Lakeshore Drive*

**CHICAGO IS HOME**

*Chicago, IL Oct. 2021*

**THE REBIRTH OF A NATION**

*Chicago, FL Feb. 2021*

**TREE OF REMEMBRANCE**

*Chicago, IL Nov. 2020*

**LET THEM STAY HOME**

*Chicago, IL May. 2020*

**Art Basel**

*Miami, FL Dec. 2018*

**Heroism, Gallery Guichard**

*Chicago, IL Mar. 2018*

**Beauty of Diversity,**

**Gallery Guichard**

*Chicago, IL Mar. 2017*

**Farewell 44, NYCH Art Gallery**

*Chicago, IL Feb. 2017*

**Harlem Fine Arts Show**

*Chicago, IL Dec. 2016*

**NYCH Art Gallery**

*Chicago, IL Sept. 2016*

**Reside Concierge**

*Chicago, IL Aug. 2016*

**JanKossen Contemporary**

**Art Gallery**

*New York, NY July 2016*

**FOUND, Gallery Guichard**

*Chicago, IL June 2016*

**M.A.Y.E.R Art Gallery**

*Chicago, IL June 2016*

**Gallery Guichard**

*Washington, DC June 2016*

**State of the Art**

*Chicago, IL June 2016*

**Kai Koto Art Galleries**

*Chicago, IL May 2016*

**Projekt30**

*Chicago, IL May 2016*

**Gallery Guichard**

*Chicago, IL Jan. 2016*

**ChiRaq Movie**

*Chicago, IL Sept. 2015*

**African Festival of the Arts**

*Chicago, IL Sept. 2015*

**100,000 Opportunities Initiative,  
Starbucks**

*Chicago, IL Sept. 2015*

**Solo Show, The Artist Lounge**

*Chicago, IL Aug. 2015*

**Gallery Guichard**

*Chicago, IL July 2014*

**Solo Show, Art Revolution**

*Chicago, IL Sept. 2013*

**Art Basel**

*Miami, FL Dec. 2013*

**DuSable Museum**

*Chicago, IL Feb. 2012*

**Gallery Guichard**

*Chicago, IL Oct. 2011*

# RECOGNITION

## **abc7chicago.com**

MLK Jr., Malcom X honored in Chicago lakefront art installation 'Demand Justice'

<https://abc7chicago.com/george-floyd-martin-luther-king-jr-mlk-malcom-x/10694435/>

## **artstribune.com**

Installation Art "Demand Justice" Commemorates George Floyd Killing

<https://artstribune.com/2021/05/26/installation-art-demand-justice-commemorates-george-floyd-killing/>

## **wgntv.com**

A look at the 'Demand Justice' sculpture that pops up for just 45 minutes at a time

<https://wgntv.com/news/features/a-look-at-the-demand-justice-sculpture-that-pops-up-for-just-45-minutes-at-a-time/>

## **abcactionnews.com**

Award winning Chicago artists new exhibit inspired by Tampa kids

<https://www.abcactionnews.com/news/region-hillsborough/award-winning-chicago-artists-new-exhibit-inspired-by-tampa-kids>

## **sheenmagazine.com**

Chicago Artist Creates "Let Them Stay Home" Virtual Art Gallery Exhibit

<http://www.sheenmagazine.com/chicago-artist-creates-let-them-stay-home-virtual-art-gallery-exhibit/>

## **news.wttw.com**

Virtual Art Gallery Explores Why the Stay-at-Home Order Isn't Ideal for All

<https://news.wttw.com/2020/05/26/virtual-art-gallery-explores-why-stay-home-order-isn-t-ideal-all>

## **thirdcoastreview.com**

Artist Maxwell Emcays Explores Race and Class Issues in Meaning of Home in Virtual...

<https://thirdcoastreview.com/2020/05/27/artist-maxwell-emcays-explores-race-and-class-issues-in-meaning-of-home-in-virtual-art-exhibit/>

## **ChicagoDefender.com**

Maxwell Emcays: Artist and Activist | The Chicago Defender

<https://chicagodefender.com/2018/09/28/chicagoans-you-should-know-artist-and-activist-maxwell-emcays/>

## **RollingOut.com**

Maxwell Emcays debuts his 'Found' exhibition at Gallery Guichard

<https://rollingout.com/2016/06/22/maxwell-mccays-debuts-artistry-found-gallery-guichard/>

## **nbcchicago.com**

Achieving Peace Through Art

<https://www.nbcchicago.com/blogs/making-a-difference/Achieving-Peace-Through-Art-312283171.html>

## **TV - Windy City Live (ABC 7)**

Chicagoan using art & activism to "DEMAND JUSTICE"

<https://www.youtube.com/watch?v=OR11pHIGIX4>

## **art.illinois.edu**

New Media alumnus, Maxwell Emcays, in the news

<https://art.illinois.edu/index.php/news/405-new-media-alumnus-maxwell-emcays-in-the-news>

## **fox32chicago.com**

Chicago artist helps make sure lives lost are never forgotten

<http://www.fox32chicago.com/news/local/chicago-artist-helps-make-sure-lives-lost-are-never-forgotten>

## **wgntv.com**

Humboldt Park residents demand end to gun violence

<https://wgntv.com/2018/01/27/humboldt-park-residents-demand-end-to-gun-violence/>

# RECOGNITION

## **chicagoist.com**

Artist Makes Laser-Carved Portraits Of Chicago Rappers Out Of Wood:

[http://chicagoist.com/2016/10/03/this\\_artist\\_makes\\_portraits\\_of\\_chic.php#photo-1](http://chicagoist.com/2016/10/03/this_artist_makes_portraits_of_chic.php#photo-1)

## **nbcchicago.com**

Fr. Pfleger Makes Spike Lee Honorary Member of St. Sabina

<https://www.nbcchicago.com/blogs/ward-room/Fr-Pfleger-Makes-Spike-Lee-Honorary-Member-of-St-Sabi-na-311774211.html>

## **mhubchicago.com**

The Steve Harvey Show: "Amazing Artwork by Maxwell Emcays"

<https://mhubchicago.com/blog/the-steve-harvey-show-amazing-artwork-by-maxwell-emcays>

## **chicagoreader.com**

HIP-HOP: Local nonprofit the Lost Childhoods uses hip-hop against youth violence

<https://www.chicagoreader.com/chicago/lost-childhoods-dusty-groove-wgn-storm-thorgerson-hipgnosis/Content?oid=7363441>

## **abc7chicago.com**

\$5K reward offered to find shooter who killed Evanston model in Englewood

[https://abc7chicago.com/news/\\$5k-reward-offered-in-murder-of-evanston-model/1069427/](https://abc7chicago.com/news/$5k-reward-offered-in-murder-of-evanston-model/1069427/)

## **wheretraveler.com**

Chicagoan Larenz Tate Goes Home in 'Bronzeville'

<https://www.wheretraveler.com/chicago/play/chicagoan-larenz-tate-goes-home-bronzeville>

## **chicago.suntimes.com**

Rev. Michael Pfleger to lead silent march on MLK's birthday

<https://chicago.suntimes.com/news/martin-luther-king-michael-pfleger-silent-march-birthday/>

# REFERENCES

**Sajdah Wendy Muhammad**  
Sajdah House  
4847 S. Woodlawn Ave  
Chicago, IL 60615  
sajdahhouse@gmail.com / 773.655.8796

**Fances Guichard | Andre Guichard**  
Gallery Guichard LLC  
436 E. 47th Street  
Chicago, IL 60653  
francesguichard@gmail.com / 708.772.9315  
andreguichard1911@gmail.com / 773.791.7003

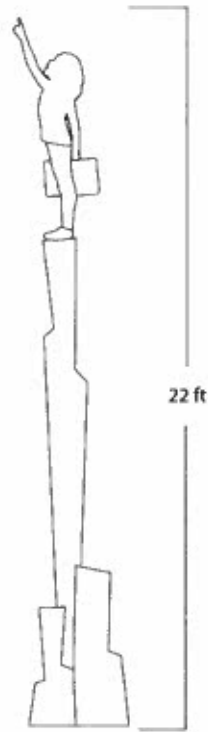
**Rip Caswell**  
Fire Birdbronze  
803 NE Harlow Rd.  
Troutdale, OR 97060  
rip@firebirdbronze.com | 503.502.7756

**Libby Larson Holdren**  
Broreren Russi Construction  
602 N. Country Fair Drive  
Champaign, IL 61821  
libby.larson@gmail.com / 217.352.4232

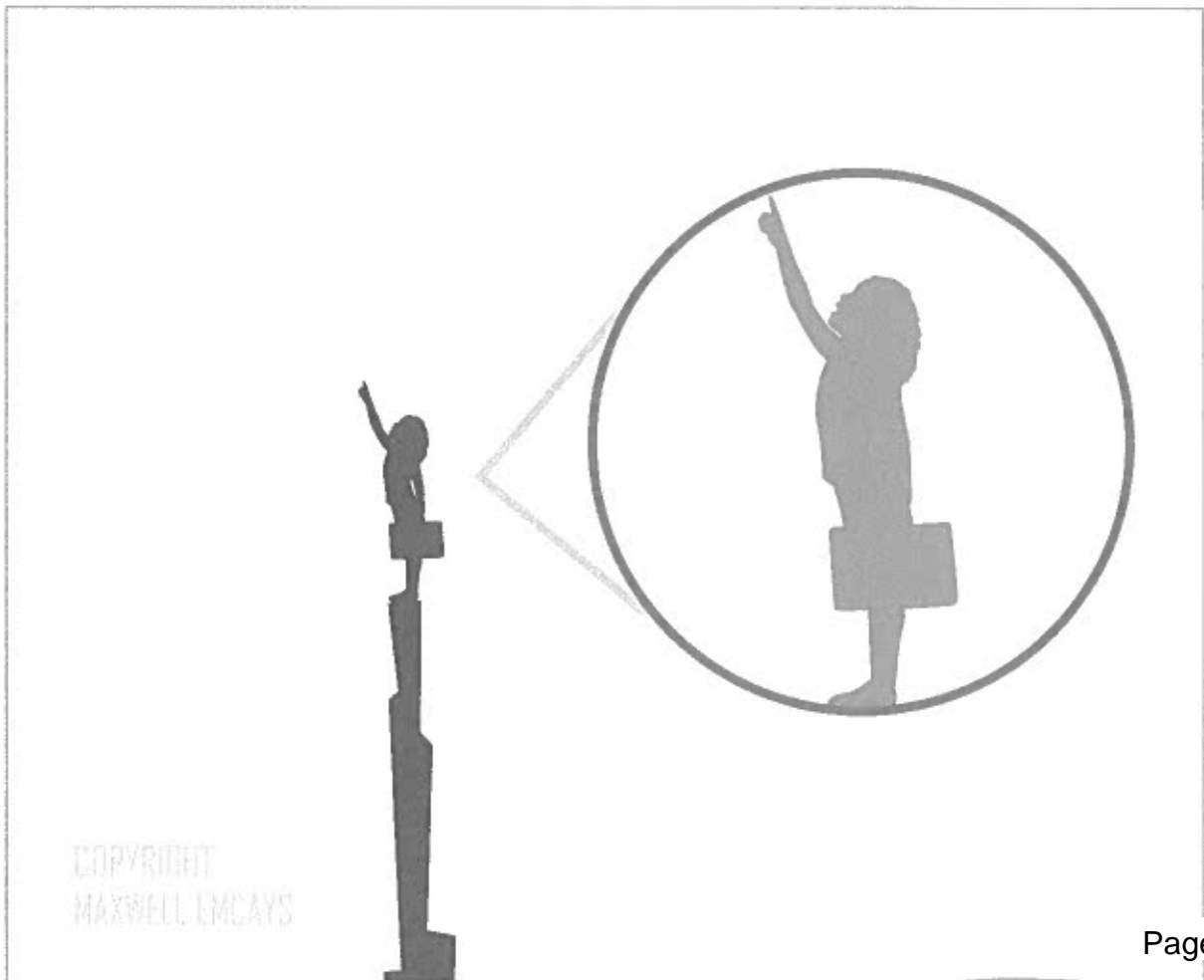
**Lucy Slivinski**  
Lucy Slivinski (Artist)  
Chicago, IL  
LucySlivinski@gmail.com / 708.280.0414

City of Jackson  
**JPAC /MLKRS Project**  
Martin Luther King Jr. Blvd - Roundabout Sculpture

**Maxwell Emcays Concepts**



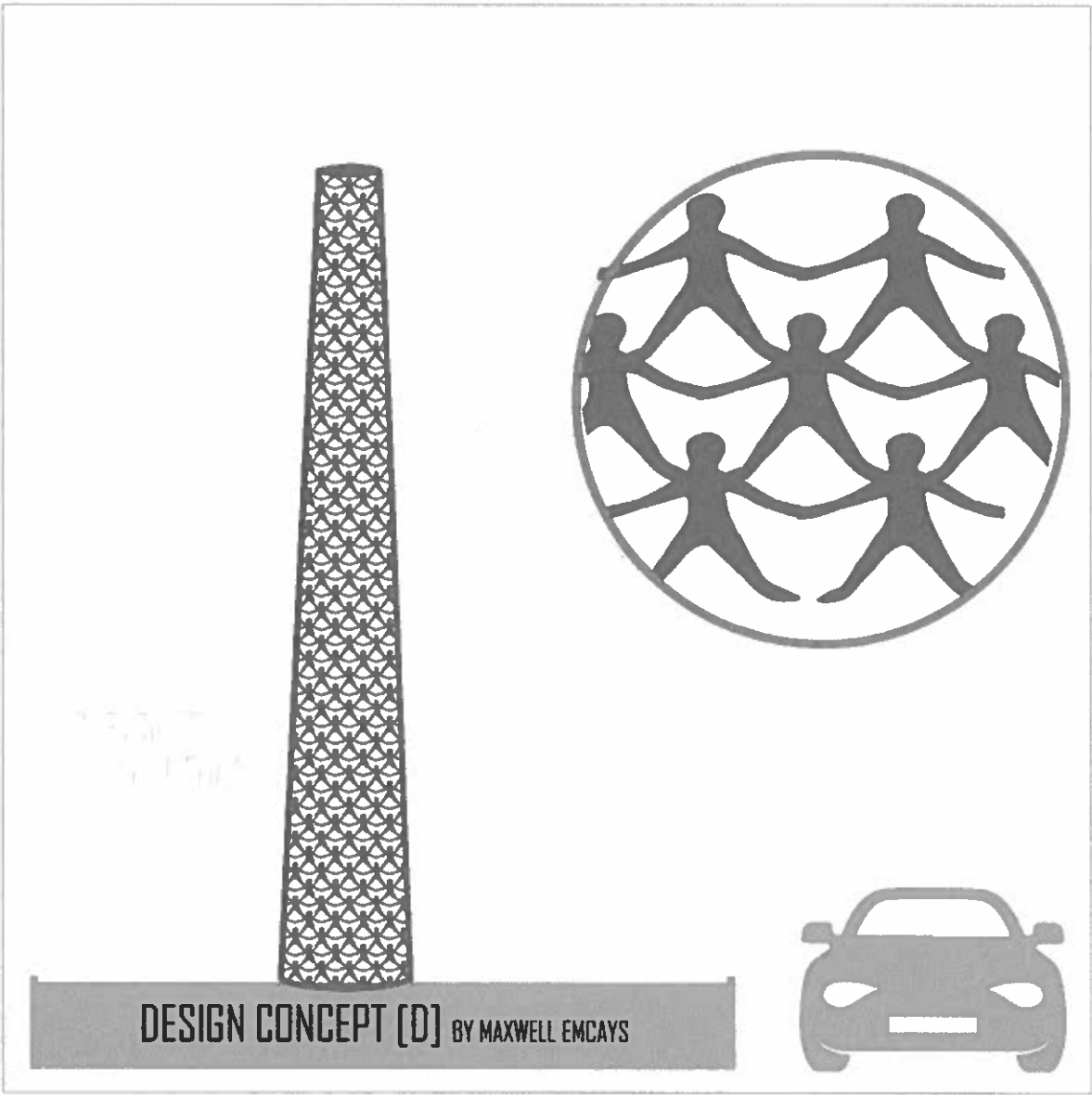
DESIGN CONCEPT (A) BY MAXWELL EMCAYS

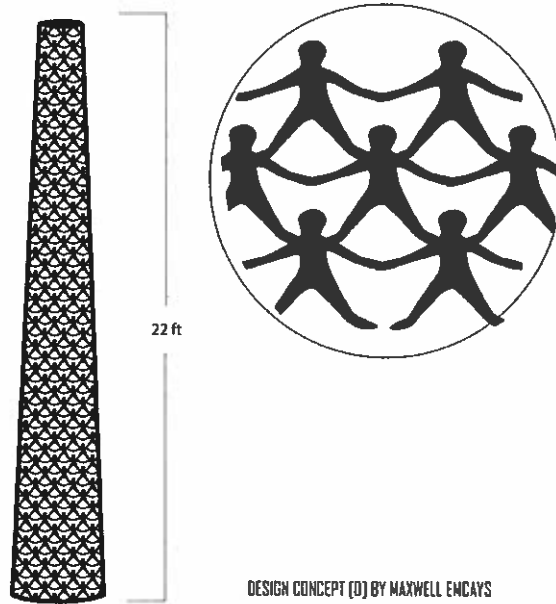
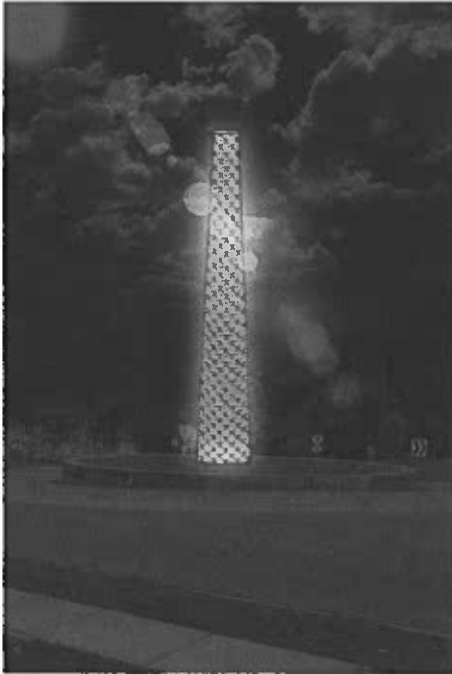


COPYRIGHT  
MAXWELL EMCAYS

Concept A is titled "Beyond the Mountain Tops". It features a young girl looking upwards imagining and reflecting on potential. She has a briefcase that alludes to her travels and ambitions that are contingent on the progress previous generations have made. She continues the dream that Dr. Martin Luther King spoke of.

Material / Method. The piece will feature a cast aluminum child figure, with aluminum facade and steel structure and concrete foundation.





DESIGN CONCEPT (D) BY MAXWELL EMCAYS

**Design D is titled "The Tower of Us / We Rise".**

**This concept brings forth the reality that it takes a community effort to reach the highest of heights. The concept depicts individuals standing on eachothers shoulders forming a tower. Similar to many challenges like the great migration; it is the strength in unity that has allowed us to rise above adversity. It is unity that will allow us to ascend to the next frontier.**

## Email Public Comment

**Kelli Hoover**

---

**From:** Recreation  
**Sent:** Thursday, December 22, 2022 8:00 AM  
**To:** Kelli Hoover  
**Subject:** Fwd: Sculpture

Sent from my iPhone

Begin forwarded message:

**From:** Stacey Nelson <stacey.nelson1@icloud.com>  
**Date:** December 22, 2022 at 7:37:17 AM EST  
**To:** Recreation <recreation@cityofjackson.org>  
**Subject:** Sculpture

I vote for Tower of tus/We Rise.

Thank you.

Sent from my iPhone

## Kelli Hoover

---

**From:** Recreation  
**Sent:** Thursday, December 22, 2022 8:12 AM  
**To:** Kelli Hoover  
**Subject:** Fwd: Roundabout Sculpture

Sent from my iPhone

Begin forwarded message:

**From:** Joani Smith <smiths4osu@comcast.net>  
**Date:** December 22, 2022 at 6:34:53 AM EST  
**To:** Recreation <recreation@cityofjackson.org>  
**Subject:** Roundabout Sculpture

Hello,

I think the Tower of Us/ We Rise should be chosen for the sculpture on MLK Boulevard's roundabout. I believe it encompasses the vision of people coming together to create something great for our community.

Joani Smith

Sent from my iPad

## Kelli Hoover

---

**From:** Recreation  
**Sent:** Thursday, December 22, 2022 8:22 AM  
**To:** Kelli Hoover  
**Subject:** Fwd: MLK Roundabout Art Installation

Sent from my iPhone

Begin forwarded message:

**From:** Kristofer Weese <kwweese@icloud.com>  
**Date:** December 21, 2022 at 9:57:46 PM EST  
**To:** Recreation <recreation@cityofjackson.org>  
**Subject:** MLK Roundabout Art Installation

To whom it may concern,

My opinion, "The Tower of Us/ We Rise" by Maxwell Emcays, could be a beacon of welcoming light in a community that feels neglected.

The arch and shapes sculptures appear to be subjective welded metal art. The shapes are anxiety inducing, and the arch looks like a dark piece. Nothing about a tower of light in my opinion is as subjective. A tower that can change light and bring beauty instead of industrial aesthetics would be more welcoming to the majority.

The piece, "Beyond the Mountain tops", is only of a girl. There are many young men in that community that may feel left out of the new art representation. We all need to be able to feel like we can accomplish more, not just young women in the community.

**Kelli Hoover**

---

**From:** Recreation  
**Sent:** Thursday, December 22, 2022 8:41 AM  
**To:** Kelli Hoover  
**Subject:** Fwd: Sculpture for MLK Drive Roundabout

Sent from my iPhone

Begin forwarded message:

**From:** Ryan Kintz <ryan@mdkrecycling.com>  
**Date:** December 22, 2022 at 8:16:22 AM EST  
**To:** Recreation <recreation@cityofjackson.org>  
**Subject:** Sculpture for MLK Drive Roundabout

They are all nice designs. I really like the Design D titled "The Tower of Us / We Rise"

Sincerely,

**Ryan Kintz**



**Scan - Shred - Storage Solutions**  
2015 Townley St.  
Jackson, MI 49203  
517-783-2450  
[www.themdkgroup.com](http://www.themdkgroup.com)

Click [here](#) to report this email as spam.

## Kelli Hoover

---

**From:** Recreation  
**Sent:** Thursday, December 22, 2022 12:48 PM  
**To:** Kelli Hoover  
**Subject:** FW: MLK Roundabout Sculpture Votes

---

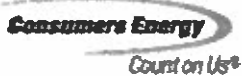
**From:** Tamara L. Reed <TAMARA.REED@cmsenergy.com>  
**Sent:** Wednesday, December 21, 2022 4:39 PM  
**To:** Recreation <recreation@cityofjackson.org>  
**Subject:** MLK Roundabout Sculpture Votes

In my humble opinion, Tower of Us/We Rise would be my first choice but the Beyond the Mountaintops is a very close second choice.

The other two sculptures do not represent the south side of the City at all.

Thank you,

**Tami Reed** | *Senior Admin Specialist II - Data & System Controls*  
T: 800.477.5050 | F: 517.325.8032  
**World Class Performance**



**Delivering Hometown Service**

Please consider the environment before you print this email.

Click [here](#) to report this email as spam.

## Kelli Hoover

---

**From:** Recreation  
**Sent:** Thursday, December 22, 2022 3:15 PM  
**To:** Kelli Hoover  
**Subject:** Fwd: MLK Drive Sculpture vote

Sent from my iPhone

Begin forwarded message:

**From:** Teresa Rodríguez Mohr <crocus\_venus@hotmail.com>  
**Date:** December 22, 2022 at 2:02:02 PM EST  
**To:** Recreation <recreation@cityofjackson.org>  
**Subject:** MLK Drive Sculpture vote

Voting for "The tower of us" for the sculpture on the roundabout.

Teresa Rodriguez

Get [Outlook for Android](#)

Click [here](#) to report this email as spam.

## Kelli Hoover

---

**From:** Recreation  
**Sent:** Thursday, December 22, 2022 9:46 PM  
**To:** Kelli Hoover  
**Subject:** Fwd: Sculpture Vote MLK Blvd.

Sent from my iPhone

Begin forwarded message:

**From:** Tamika Lagow <tamika.lagow@gmail.com>  
**Date:** December 22, 2022 at 9:42:37 PM EST  
**To:** Recreation <recreation@cityofjackson.org>  
**Subject:** Sculpture Vote MLK Blvd.

I love the Tower of Us for  
The roundabout on MLK Blvd. I think it speaks to the community of Jackson and that together  
we can.

Thank you for the opportunity to voice my opinion.

Tamika Lagow

Sent from my iPhone

**Kelli Hoover**

---

**From:** Recreation  
**Sent:** Friday, December 30, 2022 8:47 AM  
**To:** Kelli Hoover  
**Subject:** Fwd: MLK round about Sculpture

Sent from my iPhone

Begin forwarded message:

**From:** amanda belcher <belcher869@yahoo.com>  
**Date:** December 30, 2022 at 8:40:53 AM EST  
**To:** Recreation <recreation@cityofjackson.org>  
**Subject:** MLK round about Sculpture

"The Tower of Us/We Rise" by Maxwell Emcays

Sent from Yahoo Mail for iPhone

Click [here](#) to report this email as spam.

## Kelli Hoover

---

**From:** Recreation  
**Sent:** Saturday, December 31, 2022 2:06 PM  
**To:** Kelli Hoover  
**Subject:** Fwd: Tower of Us

Sent from my iPhone

Begin forwarded message:

**From:** David Howe <dlhowe49@icloud.com>  
**Date:** December 31, 2022 at 11:34:43 AM EST  
**To:** Recreation <recreation@cityofjackson.org>  
**Subject:** Tower of Us

Represents unity. Something we need more than ever.

## Kelli Hoover

---

**From:** Recreation  
**Sent:** Saturday, December 31, 2022 10:14 PM  
**To:** Kelli Hoover  
**Subject:** Fwd: I vote for The Tower of Us/We rise

Sent from my iPhone

Begin forwarded message:

**From:** Kristin Klug <kristinlou@outlook.com>  
**Date:** December 31, 2022 at 9:18:45 PM EST  
**To:** Recreation <recreation@cityofjackson.org>  
**Subject:** I vote for The Tower of Us/We rise

Sent from my T-Mobile 5G Device

Click [here](#) to report this email as spam.

## Kelli Hoover

---

**From:** Recreation  
**Sent:** Sunday, January 1, 2023 12:02 PM  
**To:** Kelli Hoover  
**Subject:** Fwd: Sculpture

Sent from my iPhone

Begin forwarded message:

**From:** Kathy Drake <kathydrake162@yahoo.com>  
**Date:** January 1, 2023 at 11:40:16 AM EST  
**To:** Recreation <recreation@cityofjackson.org>  
**Subject:** Sculpture  
**Reply-To:** Kathy Drake <kathydrake162@yahoo.com>

I vote for The Tower of US

Kathy Drake  
1212 Woodsum street

Sent from Yahoo Mail on Android

Click [here](#) to report this email as spam.

## Kelli Hoover

---

**From:** Recreation  
**Sent:** Sunday, January 1, 2023 4:26 PM  
**To:** Kelli Hoover  
**Subject:** Fwd: Sculpture

Sent from my iPhone

Begin forwarded message:

**From:** Recreation <recreation@cityofjackson.org>  
**Date:** January 1, 2023 at 12:02:18 PM EST  
**To:** Kathy Drake <kathydrake162@yahoo.com>  
**Subject: Re: Sculpture**

Thank you

Sent from my iPhone

On Jan 1, 2023, at 11:40 AM, Kathy Drake <kathydrake162@yahoo.com> wrote:

I vote for The Tower of US

Kathy Drake  
1212 Woodsum street

Sent from Yahoo Mail on Android

Click [here](#) to report this email as spam.

**Kelli Hoover**

---

**From:** Recreation  
**Sent:** Sunday, January 1, 2023 4:26 PM  
**To:** Kelli Hoover  
**Subject:** Fwd: I vote for The Tower of Us/We rise

Sent from my iPhone

Begin forwarded message:

**From:** Recreation <recreation@cityofjackson.org>  
**Date:** December 31, 2022 at 10:14:24 PM EST  
**To:** Kelli Hoover <khoover@cityofjackson.org>  
**Subject:** Fwd: I vote for The Tower of Us/We rise

Sent from my iPhone

Begin forwarded message:

**From:** Kristin Klug <kristinlou@outlook.com>  
**Date:** December 31, 2022 at 9:18:45 PM EST  
**To:** Recreation <recreation@cityofjackson.org>  
**Subject:** I vote for The Tower of Us/We rise

Sent from my T-Mobile 5G Device

Click [here](#) to report this email as spam.

**Kelli Hoover**

---

**From:** Recreation  
**Sent:** Sunday, January 1, 2023 4:27 PM  
**To:** Kelli Hoover  
**Subject:** Fwd: MLK round about Sculpture

Sent from my iPhone

Begin forwarded message:

**From:** Recreation <recreation@cityofjackson.org>  
**Date:** December 30, 2022 at 8:47:01 AM EST  
**To:** Kelli Hoover <khoover@cityofjackson.org>  
**Subject:** Fwd: MLK round about Sculpture

Sent from my iPhone

Begin forwarded message:

**From:** amanda belcher <belcher869@yahoo.com>  
**Date:** December 30, 2022 at 8:40:53 AM EST  
**To:** Recreation <recreation@cityofjackson.org>  
**Subject:** MLK round about Sculpture

"The Tower of Us/We Rise" by Maxwell Emcays

[Sent from Yahoo Mail for iPhone](#)

Click [here](#) to report this email as spam.

## Kelli Hoover

---

**From:** Recreation  
**Sent:** Sunday, January 1, 2023 4:27 PM  
**To:** Kelli Hoover  
**Subject:** Fwd: Martin Luther King Jr. Blvd - Roundabout

Sent from my iPhone

Begin forwarded message:

**From:** Recreation <recreation@cityofjackson.org>  
**Date:** December 28, 2022 at 2:17:39 PM EST  
**To:** Andy Lockwood <randomgauge@gmail.com>  
**Subject: Re: Martin Luther King Jr. Blvd - Roundabout**

Thank you

Sent from my iPhone

On Dec 28, 2022, at 2:11 PM, Andy Lockwood <randomgauge@gmail.com> wrote:

I would like to encourage one of Maxwell Emcays sculptures for the MLK roundabout. For one, the other proposed sculptures are, frankly, neither inviting nor approachable. They are what I think most would consider “high brow art” and if anything, not reflective of the intersection in question.

This is not a business hub that is attempting to draw tourism - it's a neighborhood. In any direction you go, you are propelling into a community - families and churches and schools; friends and neighbors. We don't want to put a nouveau construct that invites criticism or confusion. The community deserves a symbol - a metaphor that reflects the values that already serve the community itself: hope, togetherness. I believe that Emcays has captured that metaphor and provides a cultural signpost to remind us where we are in the city: we're in a neighborhood, surrounded by people who look out for one another. Families and friends, hopes and dreams. On that, I believe Beyond the Mountain Tops grasps that concept better than The Tower of Us, but I definitely think either pose better representation than the rest of the selections.

Thank you for your time and consideration.

Andy Lockwood, city resident

## Kelli Hoover

---

**From:** Recreation  
**Sent:** Monday, January 9, 2023 12:13 PM  
**To:** Kelli Hoover  
**Subject:** Fwd: Sculpture

Sent from my iPhone

Begin forwarded message:

**From:** michaelmahle@icloud.com  
**Date:** January 4, 2023 at 1:15:53 PM EST  
**To:** Recreation <recreation@cityofjackson.org>  
**Subject:** Sculpture

I like The Tower of Us/We Rise.  
I like the symbolism and think it would be good for the community.

Michael Mahle

Sent from my iPhone

## Kelli Hoover

---

**From:** Recreation  
**Sent:** Tuesday, January 3, 2023 7:08 AM  
**To:** Kelli Hoover  
**Subject:** Fwd: Sculpture Designs for MLK roundabout

Sent from my iPhone

Begin forwarded message:

**From:** Angelo Koprivica <go8288@wayne.edu>  
**Date:** January 2, 2023 at 10:55:03 PM EST  
**To:** Recreation <recreation@cityofjackson.org>  
**Subject:** **Sculpture Designs for MLK roundabout**

To whom it may concern,

I have reviewed the selection for roundabout proposals.

I must say, that only one of these proposals strikes me as worthy of being erected as one of the first images people see upon entering downtown Jackson. "Over the Mountain Top" is the only statue which represents something valuable and has real aesthetic value. It's straightforward in the message it conveys and inspired on lookers. "The tower of us" at least conforms to some aesthetic properties and has some wholesome qualities, but it is neither beautiful to look at nor does it inspire awe or wonder. "MLK Boulevard arch" and "Community of Shapes" have no alluring qualities to them. They are not beautiful, they do not inspire, what they represent is not straightforward and obvious, and have no redeeming aesthetic qualities. They exist simply to take up space. The roundabout would be better off without any statue than either of these eye soars taking up the space.

Citizens of Jackson deserve to be surrounded by art and architecture that affirms the dignity of the human spirit, is beautiful, and produces joy, inspiration, and happiness. The only statue that comes close to this is "Over the Mountain Top." The other three, especially "MLK Boulevard arch" and "Community of Shapes" fail to do this, and would do nothing good for our community besides be a vanity project.

With Sincere Gratitude,

Angelo Koprivica

## Kelli Hoover

---

**From:** Recreation  
**Sent:** Sunday, January 1, 2023 4:27 PM  
**To:** Kelli Hoover  
**Subject:** Fwd: MLK Roundabout Art Committeee

Sent from my iPhone

Begin forwarded message:

**From:** Recreation <recreation@cityofjackson.org>  
**Date:** December 23, 2022 at 11:14:06 AM EST  
**To:** "Anhalt, Alex K." <Alex.Anhalt@arbor.edu>  
**Subject: Re: MLK Roundabout Art Committeee**

Thank you

Sent from my iPhone

On Dec 23, 2022, at 11:05 AM, Anhalt, Alex K. <Alex.Anhalt@arbor.edu> wrote:

Regarding the sculpture decision for the MLK Roundabout, I prefer the "Beyond the Mountain Tops" concept by some margin.

Also, for what it's worth, "ML King Boulevard Arch" looks very dated and rudimentary for a modern art design.

Click [here](#) to report this email as spam.

## Kelli Hoover

---

**From:** Recreation  
**Sent:** Thursday, December 22, 2022 8:00 AM  
**To:** Kelli Hoover  
**Subject:** Fwd: Round about

Sent from my iPhone

Begin forwarded message:

**From:** wireangel618@gmail.com  
**Date:** December 22, 2022 at 7:19:04 AM EST  
**To:** Recreation <recreation@cityofjackson.org>  
**Subject:** Round about

I personally believe the Beyond the mountain tops is the best sculpture for the MLK round about not only is it beautiful but it sends a setting message that women can! As a female teenager I am going into welding wich is male dominated meaning u have to work twice as hard to get to where I need to be and this art peice really speaks to the empowerment of not only the women of todays but the generations to follow. It would be beautiful to commemoration MLK and Women.

Sent from my iPhone

**Kelli Hoover**

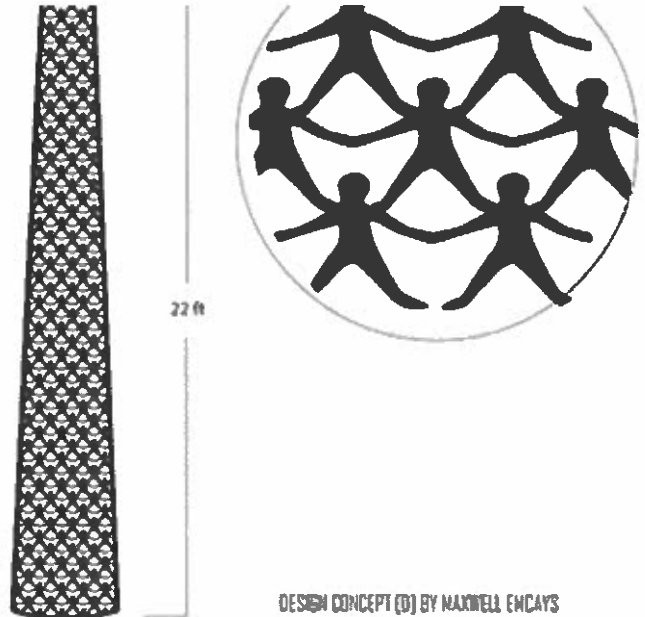
---

**From:** Recreation  
**Sent:** Thursday, December 22, 2022 12:46 PM  
**To:** Kelli Hoover  
**Subject:** FW: MLK Roundabout Art Committee

---

**From:** Trish Tacey <mootoon1@comcast.net>  
**Sent:** Thursday, December 22, 2022 10:44 AM  
**To:** Recreation <recreation@cityofjackson.org>  
**Subject:** MLK Roundabout Art Committee

As a resident of Jackson, I vote for:



"The Tower of Us/We Rise" by Maxwell Emcays

Trish Tacey

Click [here](#) to report this email as spam.

## Kelli Hoover

---

**From:** Recreation  
**Sent:** Thursday, December 22, 2022 12:48 PM  
**To:** Kelli Hoover  
**Subject:** FW: Sculpture at MLK and Morell

**From:** Andrew Bowen <abowen3@emich.edu>  
**Sent:** Wednesday, December 21, 2022 3:57 PM  
**To:** Recreation <recreation@cityofjackson.org>  
**Subject:** Sculpture at MLK and Morell

I think you should go with Beyond the Mountain Tops

Click [here](#) to report this email as spam.

## Kelli Hoover

---

**From:** Recreation  
**Sent:** Thursday, December 22, 2022 12:53 PM  
**To:** Kelli Hoover  
**Subject:** Fwd: Favorite Sculpture

Sent from my iPhone

Begin forwarded message:

**From:** pperlos <pperlos@frontiernet.net>  
**Date:** December 21, 2022 at 9:38:33 PM EST  
**To:** Recreation <recreation@cityofjackson.org>  
**Subject:** Favorite Sculpture

Beyond the Mountain Tops is my favorite

Pamela Perlos

Sent from my Verizon, Samsung Galaxy smartphone

Click [here](#) to report this email as spam.

## Kelli Hoover

---

**From:** Recreation  
**Sent:** Thursday, December 22, 2022 1:47 PM  
**To:** Kelli Hoover  
**Subject:** Fwd: Sculpture feedback

Sent from my iPhone

Begin forwarded message:

**From:** Heather Hermann <hlh22@cornell.edu>  
**Date:** December 22, 2022 at 1:45:04 PM EST  
**To:** Recreation <recreation@cityofjackson.org>  
**Subject:** Sculpture feedback

Hi,

I had a chance to look at the four options, and would like to “vote” for Beyond the Mountain tops. I like the visual of the little girl looking up at all her potential. So many girls/women settle for less for one reason or another, and the daily reminder to each for goals is important.

Thanks for your consideration,  
Heather Ries  
817 Audubon Blvd  
Jackson

Sent from my iPhone

## Kelli Hoover

---

**From:** Recreation  
**Sent:** Thursday, December 22, 2022 3:15 PM  
**To:** Kelli Hoover  
**Subject:** Fwd: Vote on sculpture MLK

Sent from my iPhone

Begin forwarded message:

**From:** brooke.roese@gmail.com  
**Date:** December 22, 2022 at 1:51:27 PM EST  
**To:** Recreation <recreation@cityofjackson.org>  
**Subject:** Vote on sculpture MLK

Beyond the mountain tops.

**Kelli Hoover**

---

**From:** Recreation  
**Sent:** Wednesday, December 28, 2022 11:31 AM  
**To:** Kelli Hoover  
**Subject:** Fwd: Sculpture choice

Sent from my iPhone

Begin forwarded message:

**From:** asteers85@gmail.com  
**Date:** December 28, 2022 at 11:29:57 AM EST  
**To:** Recreation <recreation@cityofjackson.org>  
**Subject:** Sculpture choice

I select sculpture D for the roundabout.

Sent from my iPhone

## Kelli Hoover

---

**From:** Recreation  
**Sent:** Wednesday, December 28, 2022 2:18 PM  
**To:** Kelli Hoover  
**Subject:** Fwd: Martin Luther King Jr. Blvd - Roundabout

Sent from my iPhone

Begin forwarded message:

**From:** Andy Lockwood <randomgauge@gmail.com>  
**Date:** December 28, 2022 at 2:11:20 PM EST  
**To:** Recreation <recreation@cityofjackson.org>  
**Subject:** Martin Luther King Jr. Blvd - Roundabout

I would like to encourage one of Maxwell Emcays sculptures for the MLK roundabout. For one, the other proposed sculptures are, frankly, neither inviting nor approachable. They are what I think most would consider “high brow art” and if anything, not reflective of the intersection in question.

This is not a business hub that is attempting to draw tourism - it's a neighborhood. In any direction you go, you are propelling into a community - families and churches and schools; friends and neighbors. We don't want to put a nouveau construct that invites criticism or confusion. The community deserves a symbol - a metaphor that reflects the values that already serve the community itself: hope, togetherness. I believe that Emcays has captured that metaphor and provides a cultural signpost to remind us where we are in the city: we're in a neighborhood, surrounded by people who look out for one another. Families and friends, hopes and dreams. On that, I believe Beyond the Mountain Tops grasps that concept better than The Tower of Us, but I definitely think either pose better representation than the rest of the selections.

Thank you for your time and consideration.

Andy Lockwood, city resident

## Kelli Hoover

---

**From:** Recreation  
**Sent:** Wednesday, December 28, 2022 6:27 PM  
**To:** Kelli Hoover  
**Subject:** Fwd: Beyond the mountain tops

Sent from my iPhone

Begin forwarded message:

**From:** Jenny Murphy <jenniferphelan18@gmail.com>  
**Date:** December 28, 2022 at 6:13:24 PM EST  
**To:** Recreation <recreation@cityofjackson.org>  
**Subject:** **Beyond the mountain tops**

I like the beyond the mountain tops sculpture!

Jenny

## Kelli Hoover

---

**From:** Recreation  
**Sent:** Thursday, December 29, 2022 8:37 AM  
**To:** Kelli Hoover  
**Subject:** Fwd: "Beyond the Mountain Tops" by Maxwell Emcays

Sent from my iPhone

Begin forwarded message:

**From:** Rachel Bronson <rchlbronson@yahoo.com>  
**Date:** December 29, 2022 at 12:55:50 AM EST  
**To:** Recreation <recreation@cityofjackson.org>  
**Subject:** "Beyond the Mountain Tops" by Maxwell Emcays  
**Reply-To:** Rachel Bronson <rchlbronson@yahoo.com>

"Beyond the Mountain Tops" by Maxwell Emcays

Sent from Yahoo Mail on Android

Click [here](#) to report this email as spam.

## Kelli Hoover

---

**From:** Recreation  
**Sent:** Friday, December 30, 2022 8:46 AM  
**To:** Kelli Hoover  
**Subject:** Fwd: Roundabout sculpture

Sent from my iPhone

Begin forwarded message:

**From:** Sophie Meuch <sophiameuch@gmail.com>  
**Date:** December 29, 2022 at 11:41:19 PM EST  
**To:** Recreation <recreation@cityofjackson.org>  
**Subject: Roundabout sculpture**

I really like the “Beyond the Mountaintops” sculpture. I saw you are looking for feedback and wanted to share my opinion.

-Sophie Meuch  
Jackson resident

Sent from my iPhone

## Kelli Hoover

---

**From:** Recreation  
**Sent:** Friday, December 30, 2022 8:46 AM  
**To:** Kelli Hoover  
**Subject:** Fwd: Roundabout sculpture

Sent from my iPhone

Begin forwarded message:

**From:** Sophie Meuch <sophiameuch@gmail.com>  
**Date:** December 29, 2022 at 11:41:19 PM EST  
**To:** Recreation <recreation@cityofjackson.org>  
**Subject: Roundabout sculpture**

I really like the “Beyond the Mountaintops” sculpture. I saw you are looking for feedback and wanted to share my opinion.

-Sophie Meuch  
Jackson resident

Sent from my iPhone

# Open House Public Comment

**Martin Luther King Jr.  
Roundabout Sculpture  
Community Input Form**

Artist: Maxwell Emcay

Piece: Path to Progress

Comments: The Community  
Coming Together  
United as One

**Martin Luther King Jr.  
Roundabout Sculpture  
Community Input Form**

Artist: \_\_\_\_\_

Piece: \_\_\_\_\_

Comments: Path to  
Progress.

Did not like the bronze  
case. But like the piece  
Like the light

**Martin Luther King Jr.  
Roundabout Sculpture  
Community Input Form**

Artist: Emcay

Piece: Path - Mountain top

Comments: Bro. Emcay captures  
the spirit of our  
community.

He gets my vote

**Martin Luther King Jr.  
Roundabout Sculpture  
Community Input Form**

Artist: EMCAY

Piece: \_\_\_\_\_

Comments: \_\_\_\_\_

THE PEOPLE HOLDING HARD  
WILL BE LOST AGAIN!  
A CLEAR BACK ROUND  
COLORS PLEXIGLASS  
WOULD MAKE IT  
POT MORE

**Martin Luther King Jr.  
Roundabout Sculpture  
Community Input Form**

Artist: Maxwell Encays  
Piece: Path to Progress  
Comments: Good Choice

**Martin Luther King Jr.  
Roundabout Sculpture  
Community Input Form**

Artist: Maxwell Encays  
Piece: Path to Progress  
Comments: Love the greenery  
around the sculpture &  
the people holding hands  
as unity. Also love the  
illumination. Would like  
to see a different shape  
It looks a lot like a Christmas  
tree. Thank you for your hard work!

**Martin Luther King Jr.  
Roundabout Sculpture  
Community Input Form**

Artist: Maxwell Encays  
Piece: Path to Progress  
Comments: the interconnection  
of people necessary  
to make good  
change is exemplified  
in the figures holding  
hands & standing on  
shoulders

**Martin Luther King Jr.  
Roundabout Sculpture  
Community Input Form**

Artist: Maxwell Encays  
Piece: Path to Progress  
Comments: Love the people are  
linked together and holding  
each other up. Unity &  
strength are strongly  
represented.

**Martin Luther King Jr.  
Roundabout Sculpture  
Community Input Form**

Artist: Maxwell Emcays

Piece: Beyond the Mountain Top

Comments: This shows what  
King was  
King about people  
or Reaching for the  
Mountain Top. of their  
dreams

**Martin Luther King Jr.  
Roundabout Sculpture  
Community Input Form**

Artist: \_\_\_\_\_

Piece: \_\_\_\_\_

Comments: \_\_\_\_\_

Mountain Top  
To show the ability  
to add names of  
community leaders  
years later 2  
like the likes

**Martin Luther King Jr.  
Roundabout Sculpture  
Community Input Form**

Artist: Maxwell Emcays

Piece: Beyond the Mountain Top

Comments: represents the  
vision of MLK

\_\_\_\_\_  
\_\_\_\_\_  
\_\_\_\_\_  
\_\_\_\_\_

# **Doug Jones and Chris Turner**

- Original Request for Art Application
- Interviewed against 12 other artist
- Finalist application and submission
- Attached emailed Public input copies
- Attached Open House Public input copies

---

**Jackson Public Arts Commission  
Martin Luther King Jr. Blvd Roundabout  
Sculpture**

**Project Details**

---

**Table of contents:**

**Sculpture Specifications**

**Timeline**

**Budget / Payment Schedule**

**Insurance (example)**

**Site Specifications**

**Finished Sculpture Designs**

**Conceptual Sculpture Designs**

## Sculpture Specifications

### Process and Fabrication Description

The fabrication process or work plan is comprised of several process implemented at the same time. Everything starts at the drafting of the sculpture installation. From the initial design, the refinement and scaling of the design comes into place. Once that has been established, the process of scaling design follows. Upon completion of the finalized designs, fabrication commences. Materials, vendors and assistance will be engaged. Individual components will be fabricated and assembled into the final sculpture. In conjunction with this process, site visits and consultations with the JPAC team about the foundation and progress updates will occur as necessary. Design elements and weight determinations will be forwarded as the fabrication progresses. Once the fabrication process is completed, the sculptures undergo a finishing phase before the coating process.

During fabrication, the site foundation and preparation continues with advice and consultations with the contractors and city. After inspection and approval of the foundation and installation pad has been received from the city and JPAC representatives, transportation for delivery of the final pieces from the powder coater will be scheduled for delivery to the studio for final assembly and then proceed to the site. The sculptures will be delivered and installed under my supervision, in coordination with the City of Jackson Building and Engineering inspectors. Following MiOSHA regulations and procedures the sculptures will be installed. Collaborating with the JPAC team, suggestions for lighting the pieces, and final landscaping design is completed. A final check and polishing will occur before acceptance.

Jackson Public Arts Commission  
Martin Luther King Jr. Blvd-Roundabout Sculpture  
Project Committee

Timeline:

January 2023

Project Confirmation  
Insurance  
Contract  
Permits/Excavation (Foundation)  
Begin fabrication process

February

JPAC/MLKRS project updates (meetings-studio visits).  
Fabrication continues  
Site visit (confirm foundation specs).  
Attachment bolts with subgrade anchors.

March

JPAC/MLKRS project updates (site visits-logistics).  
Prepare and pouring of sculpture foundation/curing time  
Fabrication continues  
Metal finishing stage begins  
Above grade galvanized pedestals (fabricating).

April

Powdercoating/Exterior finishing of sculptures  
Site preparation

JPAC/MLKRS updates (finishing/installation/transportation).

April/May

Finishing/installation

Transport finished sculptures to site for installation.

Careful packing and securing of all related components and installation equipment.

Finished sculptures installed.

Final inspection and sign off

Project completion

Jackson Public Arts Commission  
Martin Luther King Jr. Blvd-Roundabout Sculpture  
Project Committee

**Budget:**

Permits,accounting,logistics and legal.	\$4500
Design,Artwork purchase,operating costs.	\$11,000
Materials,fabrication equipment,consumables.	\$5000
Installation,site preparation,labor.	\$4000
Transportation,outsourcing,ect.	\$2500
Equipment,specific tools required.	\$1000
Finishing process,galvanizing,powder coating.	
<b>Budget Grand Total:</b>	<b>\$30,000</b>

**Payment schedule:**

50% of total budget (\$15,000) is required to begin the fabrication and construction process.

25% of remaining balance (\$7500) will be required towards the halfway point of the project.

25% of the total budget which is the balance (\$7500) will be required upon completion of the project installation and agreement of JPAC and MLKRS Project Committee

This budget payment schedule has been made specifically for this project.

Thank you.

THIS CERTIFICATE IS ISSUED AS A MATTER OF INFORMATION ONLY AND CONFERS NO RIGHTS UPON THE CERTIFICATE HOLDER. THIS CERTIFICATE DOES NOT AFFIRMATIVELY OR NEGATIVELY AMEND, EXTEND OR ALTER THE COVERAGE AFFORDED BY THE POLICIES BELOW. THIS CERTIFICATE OF INSURANCE DOES NOT CONSTITUTE A CONTRACT BETWEEN THE ISSUING INSURER(S), AUTHORIZED REPRESENTATIVE OR PRODUCER, AND THE CERTIFICATE HOLDER.

IMPORTANT: If the certificate holder is an ADDITIONAL INSURED, the policy(ies) must be endorsed. If SUBROGATION IS WAIVED, subject to the terms and conditions of the policy, certain policies may require an endorsement. A statement on this certificate does not confer rights to the certificate holder in lieu of such endorsement(s).

<b>PRODUCER</b> VTC Insurance Group 37000 Grand River Ave Ste 150  Farmington Hills MI 48335	<b>CONTACT NAME:</b> Michelle Caponi <b>PHONE (A/C No./Ext):</b> (248) 471-0970 <b>FAX (A/C No.):</b> (248) 471-0641 <b>E-MAIL ADDRESS:</b>	
	<b>INSURER(S) AFFORDING COVERAGE</b>	
<b>INSURED</b> Chris Turner 5203 Loraine St  Detroit MI 48208	<b>INSURER A:</b> Hartford Insurance NAIC # 21822	
	<b>INSURER B:</b>	
	<b>INSURER C:</b>	
	<b>INSURER D:</b>	
	<b>INSURER E:</b>	
	<b>INSURER F:</b>	

**COVERAGES**      **CERTIFICATE NUMBER:** 20-21 Master Cert      **REVISION NUMBER:**

THIS IS TO CERTIFY THAT THE POLICIES OF INSURANCE LISTED BELOW HAVE BEEN ISSUED TO THE INSURED NAMED ABOVE FOR THE POLICY PERIOD INDICATED. NOTWITHSTANDING ANY REQUIREMENT, TERM OR CONDITION OF ANY CONTRACT OR OTHER DOCUMENT WITH RESPECT TO WHICH THIS CERTIFICATE MAY BE ISSUED OR MAY PERTAIN, THE INSURANCE AFFORDED BY THE POLICIES DESCRIBED HEREIN IS SUBJECT TO ALL THE TERMS, EXCLUSIONS AND CONDITIONS OF SUCH POLICIES. LIMITS SHOWN MAY HAVE BEEN REDUCED BY PAID CLAIMS.

INSR LTR	TYPE OF INSURANCE	ADOL INSD	SUBR WVD	POLICY NUMBER	POLICY EFF (MM/DD/YYYY)	POLICY EXP (MM/DD/YYYY)	LIMITS
A	<input checked="" type="checkbox"/> COMMERCIAL GENERAL LIABILITY <input type="checkbox"/> CLAIMS-MADE <input checked="" type="checkbox"/> OCCUR  GEN'L AGGREGATE LIMIT APPLIES PER: <input checked="" type="checkbox"/> POLICY <input type="checkbox"/> PRO-JECT <input type="checkbox"/> LOC <input type="checkbox"/> OTHER			35880484KD	8/21/2020	8/21/2021	EACH OCCURRENCE \$ 1,000,000 DAMAGE TO RENTED PREMISES (Ea occurrence) \$ 1,000,000 MED EXP (Any one person) \$ 10,000 PERSONAL & ADV INJURY \$ 1,000,000 GENERAL AGGREGATE \$ 2,000,000 PRODUCTS - COMPIOPAGG \$ 2,000,000 Employment Practices Liability Insu \$ 25,000
	<b>AUTOMOBILE LIABILITY</b> <input type="checkbox"/> ANY AUTO <input type="checkbox"/> ALL OWNED AUTOS <input type="checkbox"/> SCHEDULED AUTOS NON-OWNED AUTOS <input type="checkbox"/> HIRED AUTOS						COMBINED SINGLE LIMIT (Ea accident) \$ BODILY INJURY (Per person) \$ BODILY INJURY (Per accident) \$ PROPERTY DAMAGE (Per accident) \$ \$
	<input type="checkbox"/> UMBRELLA LIAB <input type="checkbox"/> OCCUR <input type="checkbox"/> EXCESS LIAB <input type="checkbox"/> CLAIMS-MADE DED    RETENTION \$						EACH OCCURRENCE \$ AGGREGATE \$ \$
	<b>WORKERS COMPENSATION AND EMPLOYERS' LIABILITY</b> ANY PROPRIETOR/PARTNER/EXECUTIVE OFFICER/MEMBER EXCLUDED? (Mandatory in NH) If yes, describe under DESCRIPTION OF OPERATIONS below	Y/N	N/A				PER STATUTE    OYH-ER E.L. EACH ACCIDENT \$' E.L. DISEASE - EA EMPLOYEE \$ E.L. DISEASE - POLICY LIMIT \$

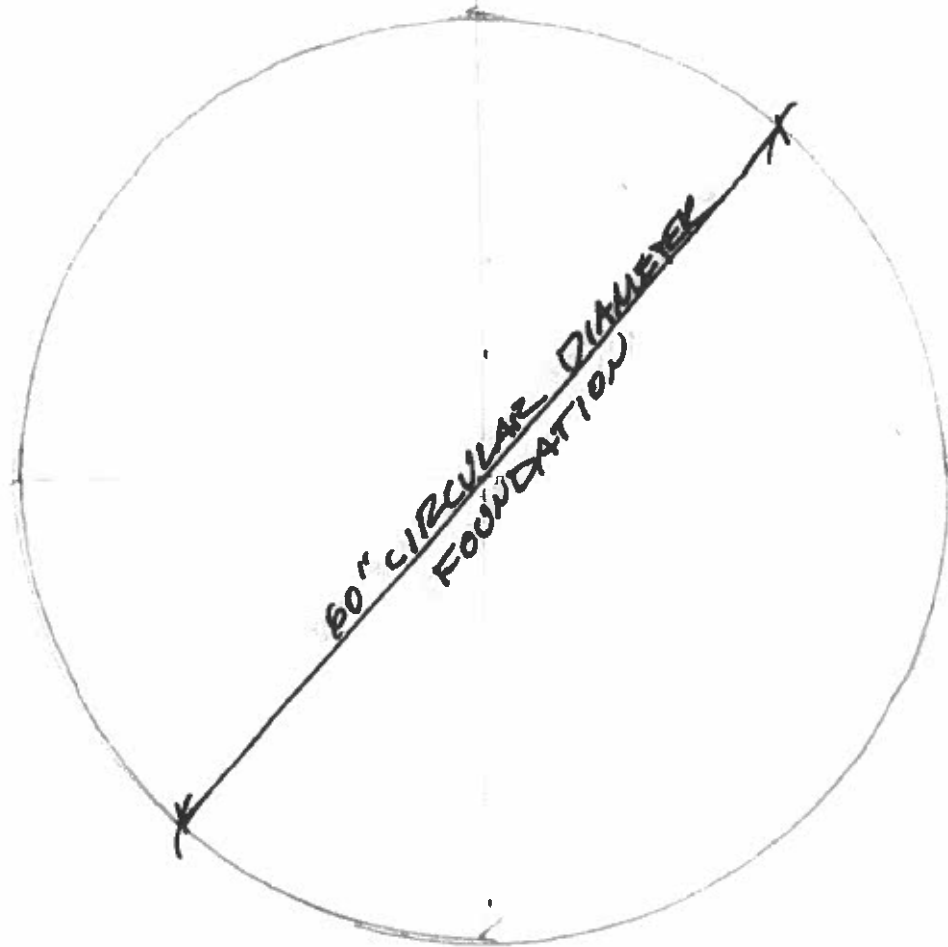
DESCRIPTION OF OPERATIONS / LOCATIONS / VEHICLES (ACORD 101, Additional Remarks Schedule, may be attached if more space is required)

<b>CERTIFICATE HOLDER</b>  Gratiot Service Properties LLC Proof of Coverage	<b>CANCELLATION</b>  SHOULD ANY OF THE ABOVE DESCRIBED POLICIES BE CANCELLED BEFORE THE EXPIRATION DATE THEREOF, NOTICE WILL BE DELIVERED IN ACCORDANCE WITH THE POLICY PROVISIONS.
	AUTHORIZED REPRESENTATIVE  Alan Chandler/V164 <i>Alan P. Chandler</i>



\* FOUNDATIONS  
↑  
DETAILS

PLAN VIEW



ABOVE GRADE

6"

LEVEL CONCRETE SURFACE

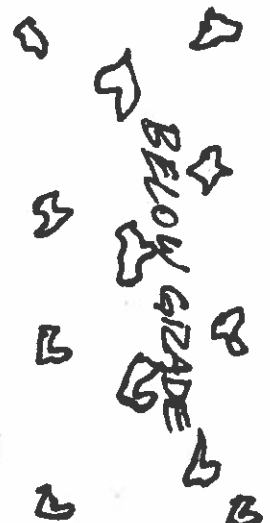
ABOVE GRADE

6"

BELOW GRADE

42"

48" TOTAL



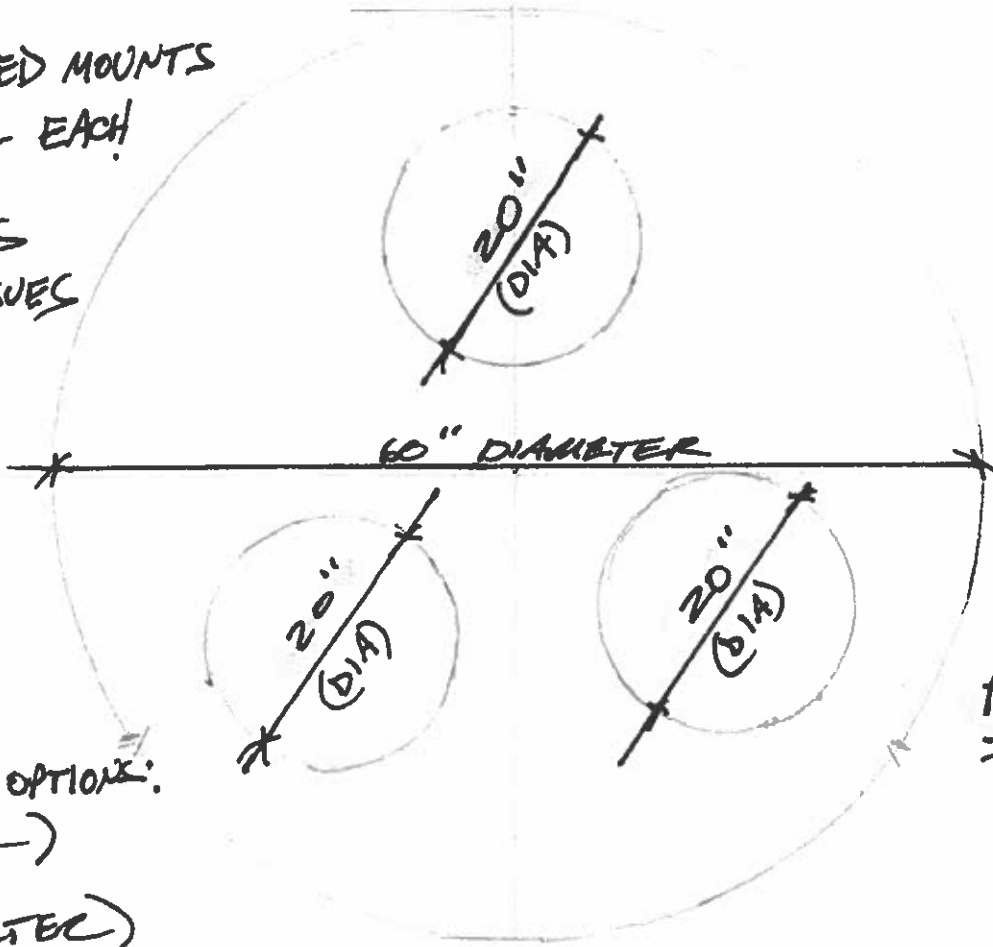
ELEVATION

FROST LINE @ 42" DEPTH

③ GALVANIZED 1/4" THICK SCULPTURE PEDISTALS

\* GALVANIZED MOUNTS  
48" TALL EACH

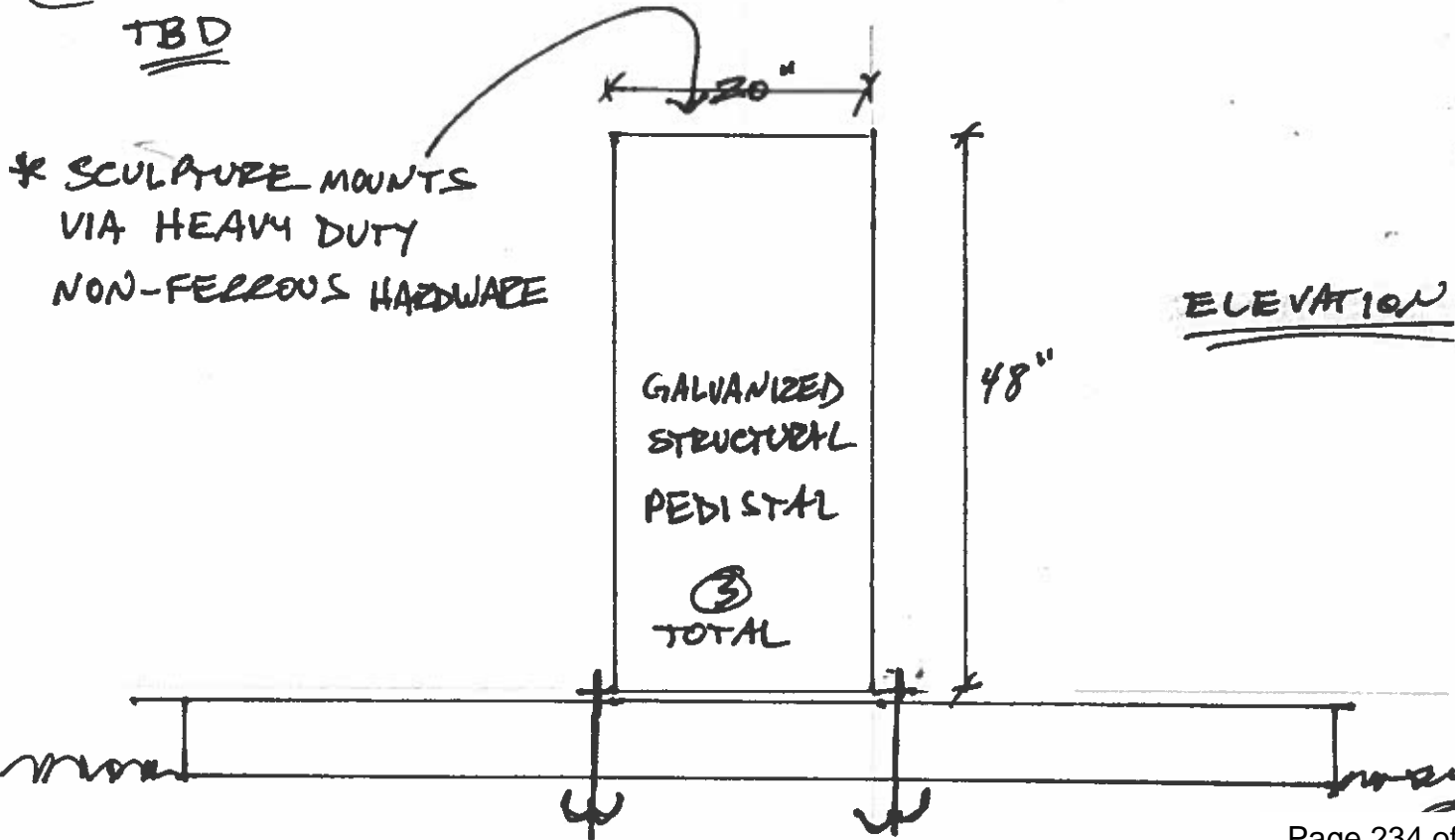
\* ADDRESSES  
SAFETY ISSUES



PLAN VIEW

\* LIGHTING OPTIONS:  
(CENTER)  
(PERIMETER)  
TBD

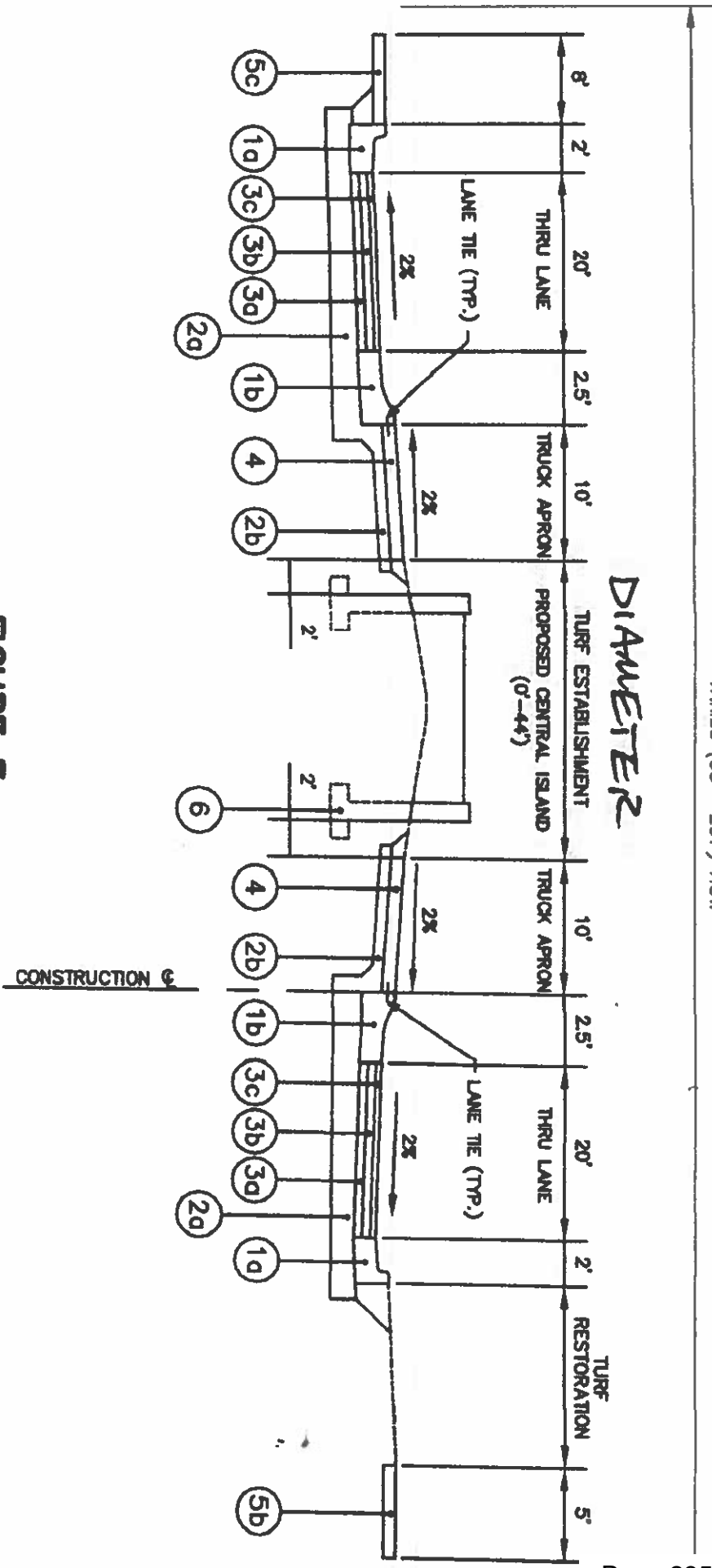
\* SCULPTURE MOUNTS  
VIA HEAVY DUTY  
NON-FERROUS HARDWARE



ELEVATION

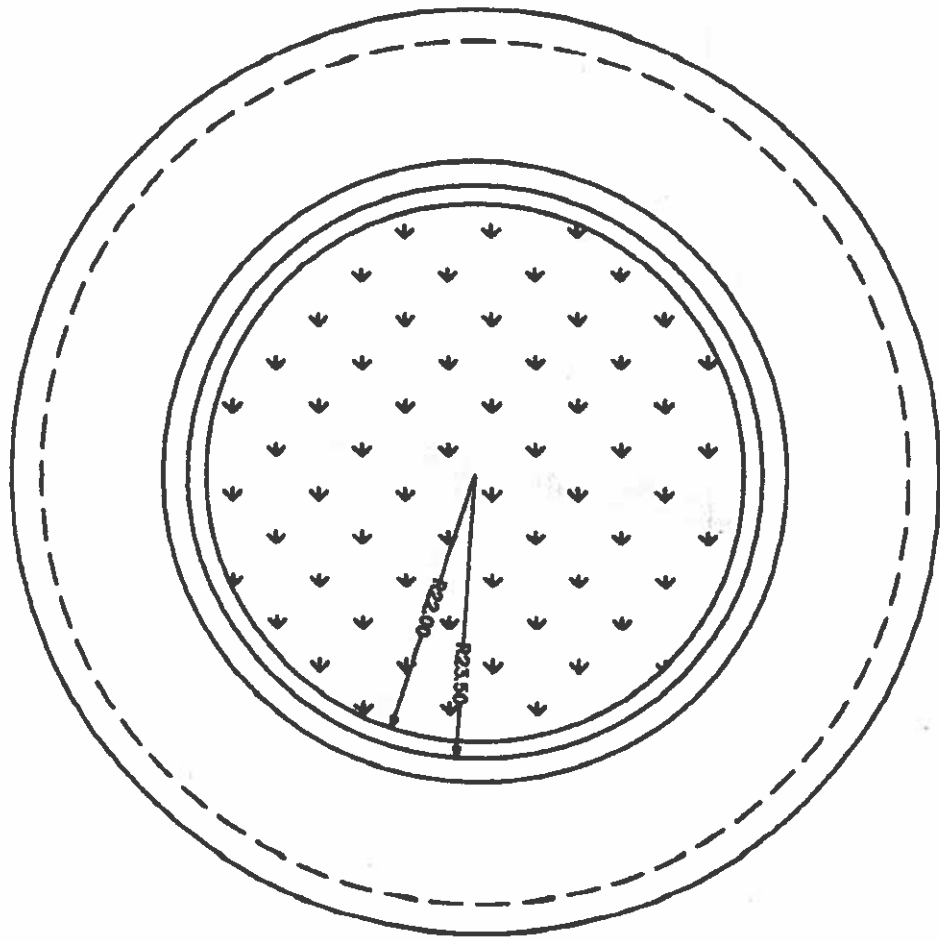
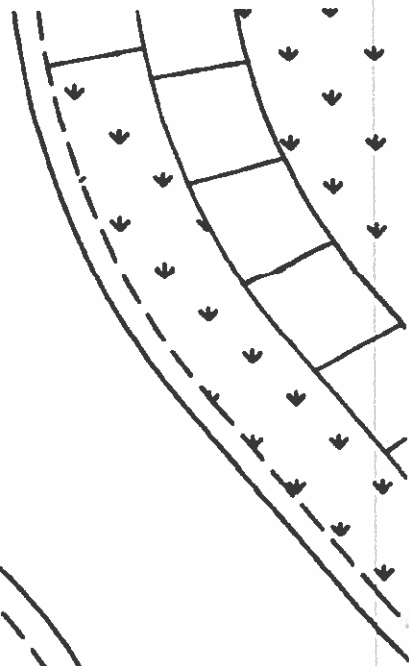
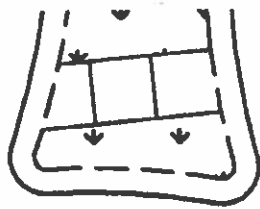
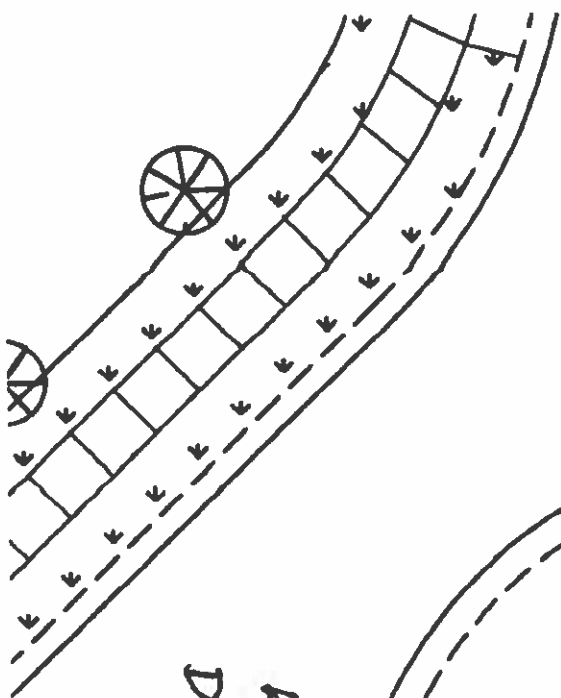
VARIABLES (66' - 201') ROW

DIAMETER

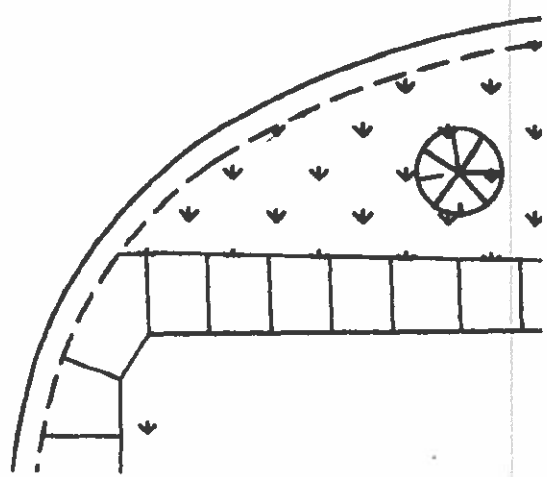
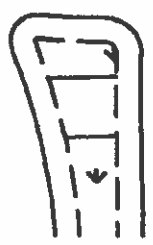
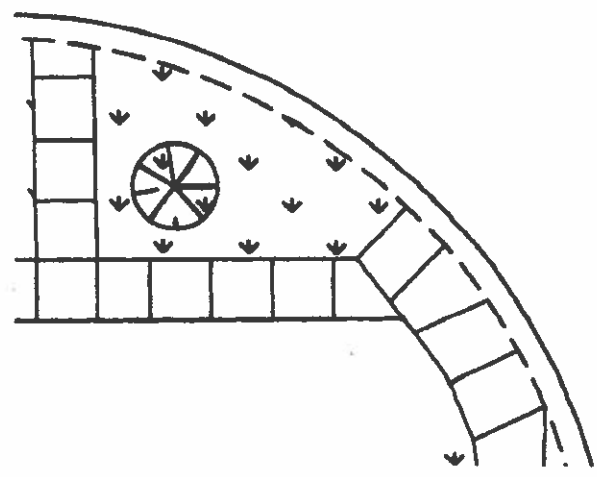


**FIGURE E**

TYPICAL CROSS SECTION OF PROPOSED CONSTRUCTION  
STA 101+66 TO STA 102+85  
ON MARTIN LUTHER KING, JR DRIVE  
STA 12+28 TO STA 13+64  
ON MORRELL STREET

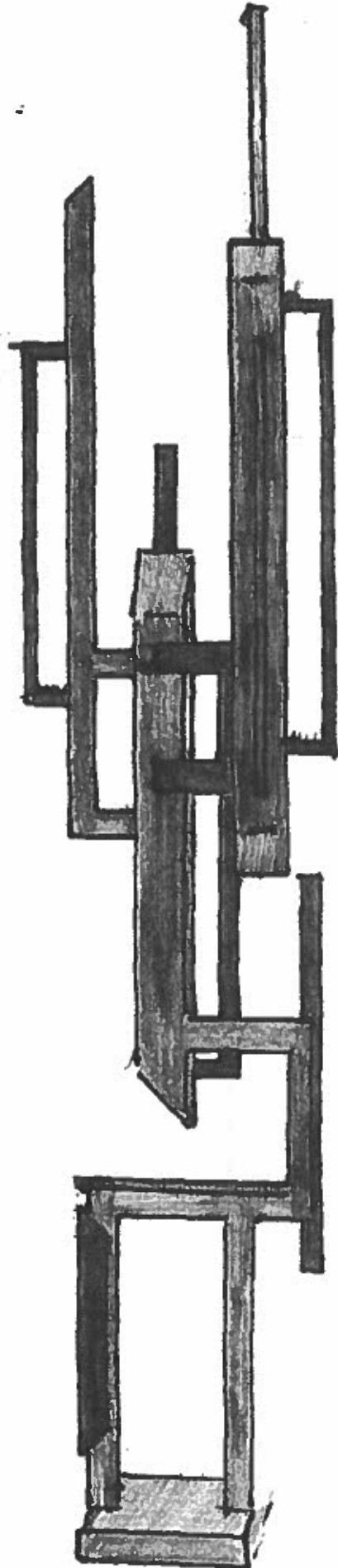


RADIUS = 22'  
 DIAMETER = 44'



ORIGINAL SCULPTURE DESIGN

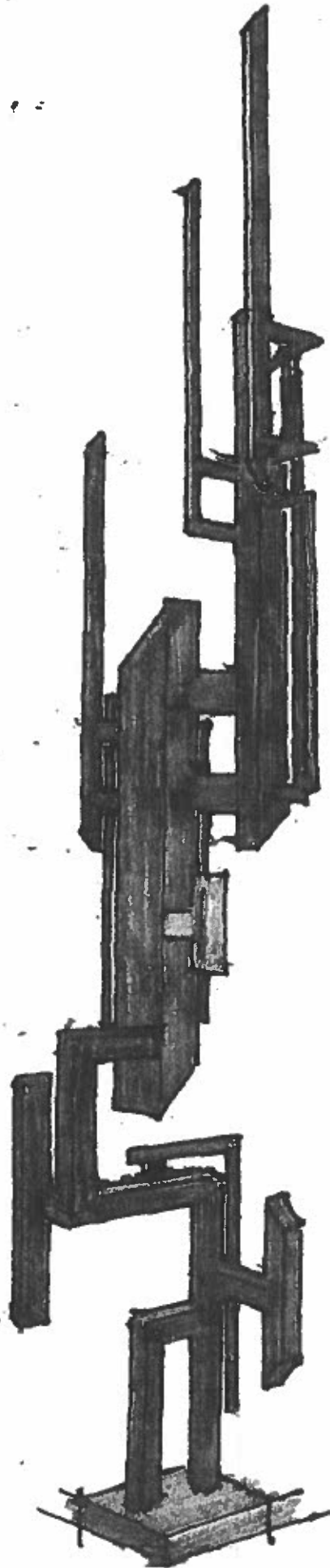
#7



C. Turner

ORIGINAL SCULPTURE DESIGN

#2

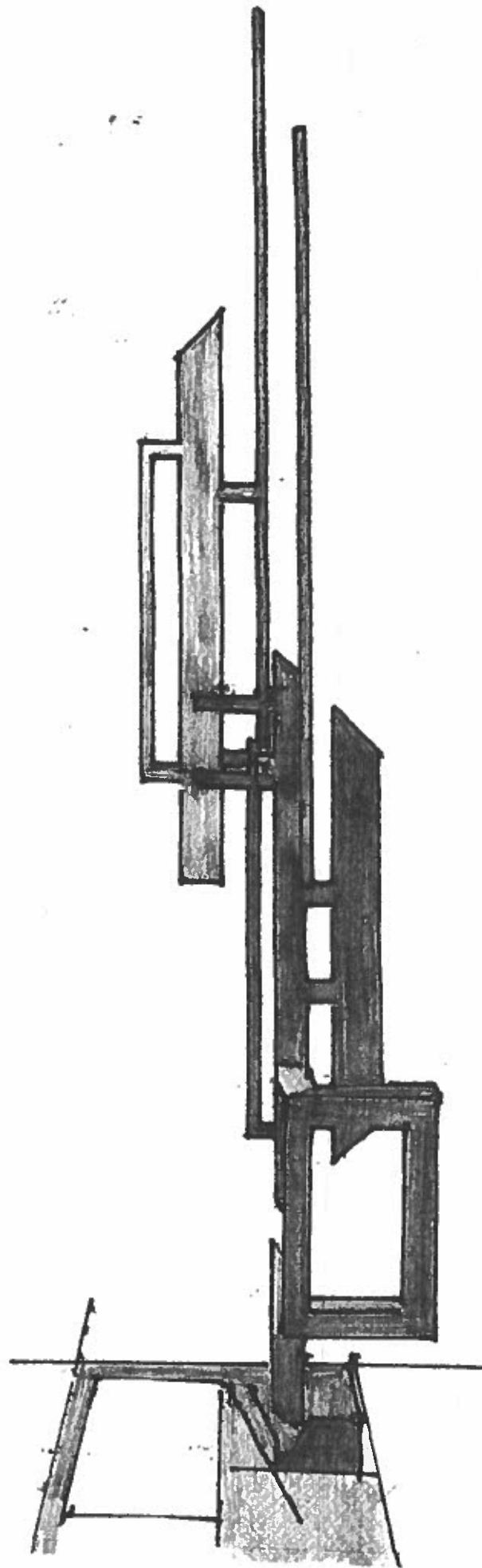


C. TURNER

2

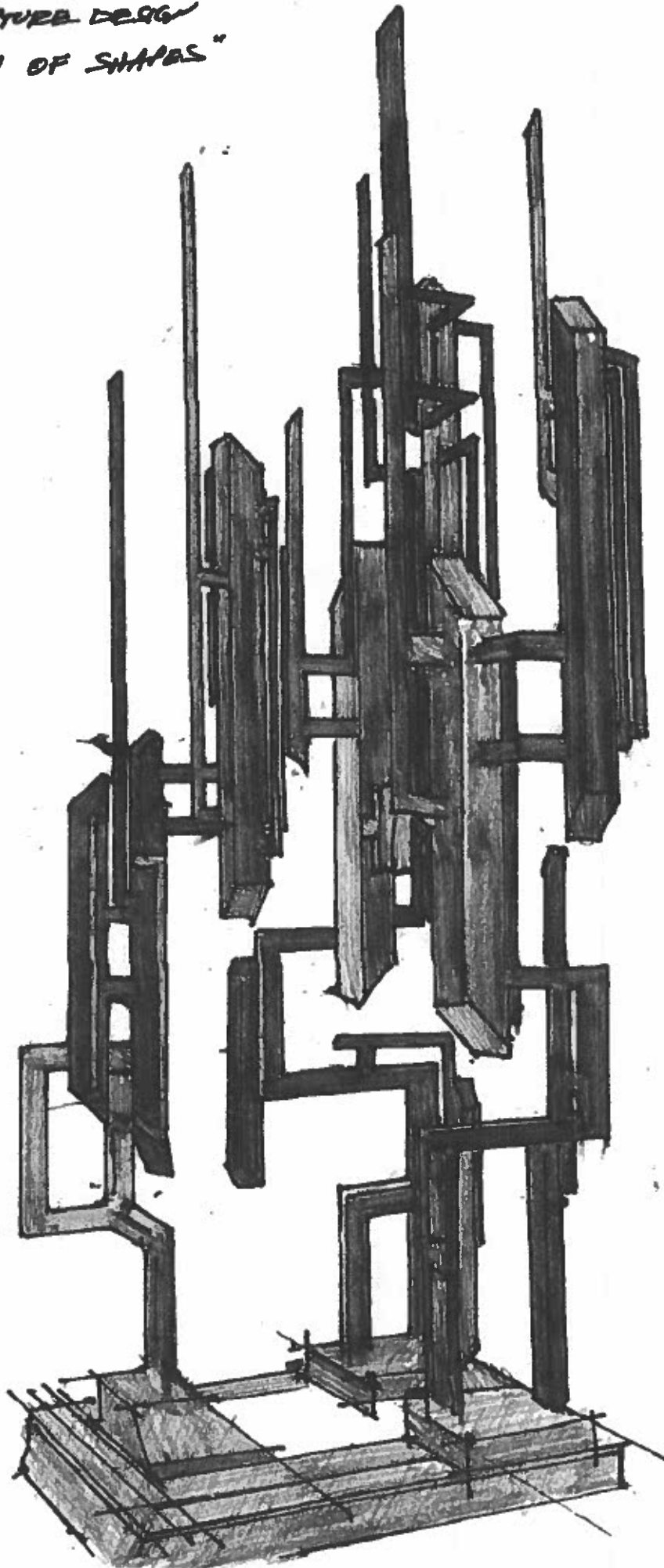
ORIGINAL SCULPTURE DESIGN

#3



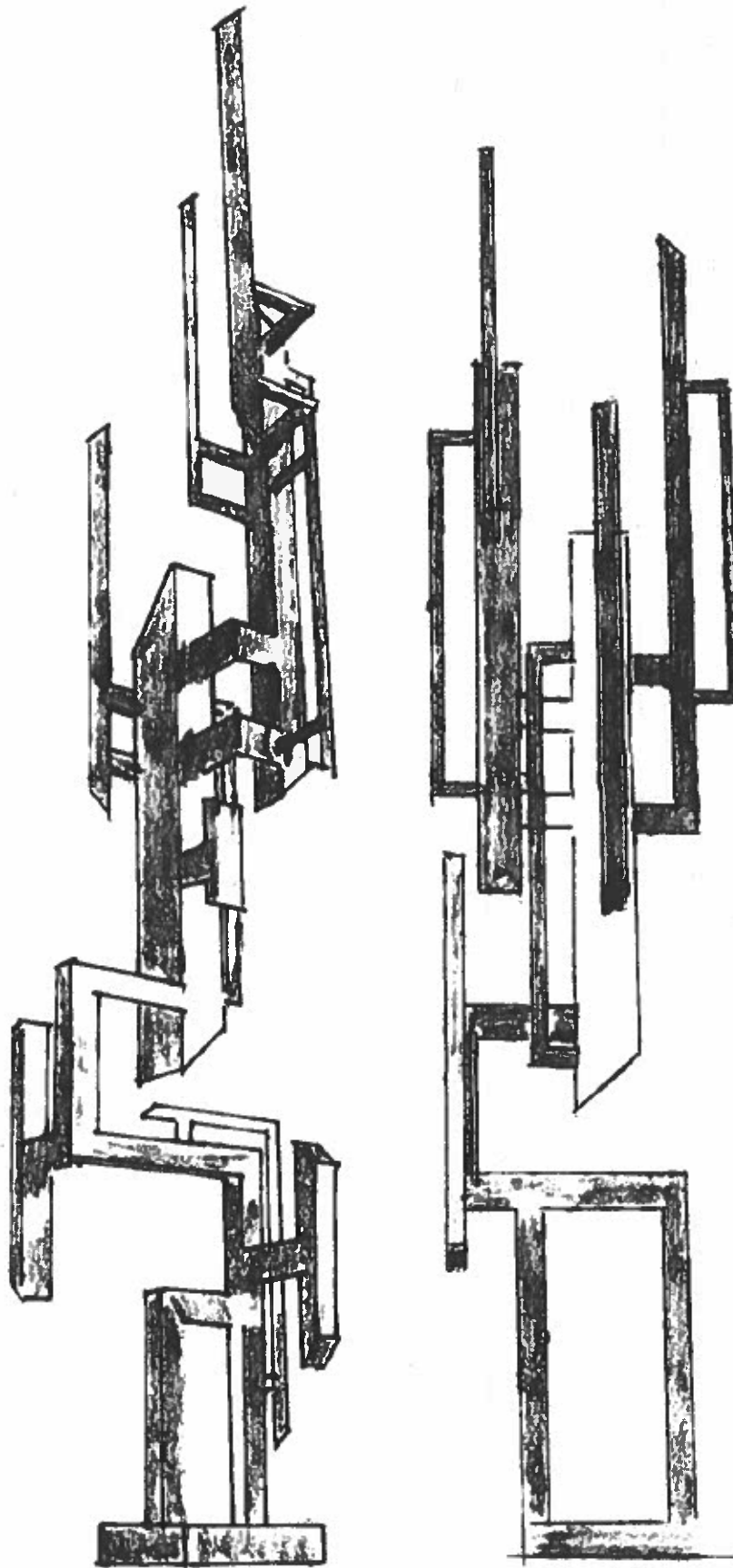
C. TURNER

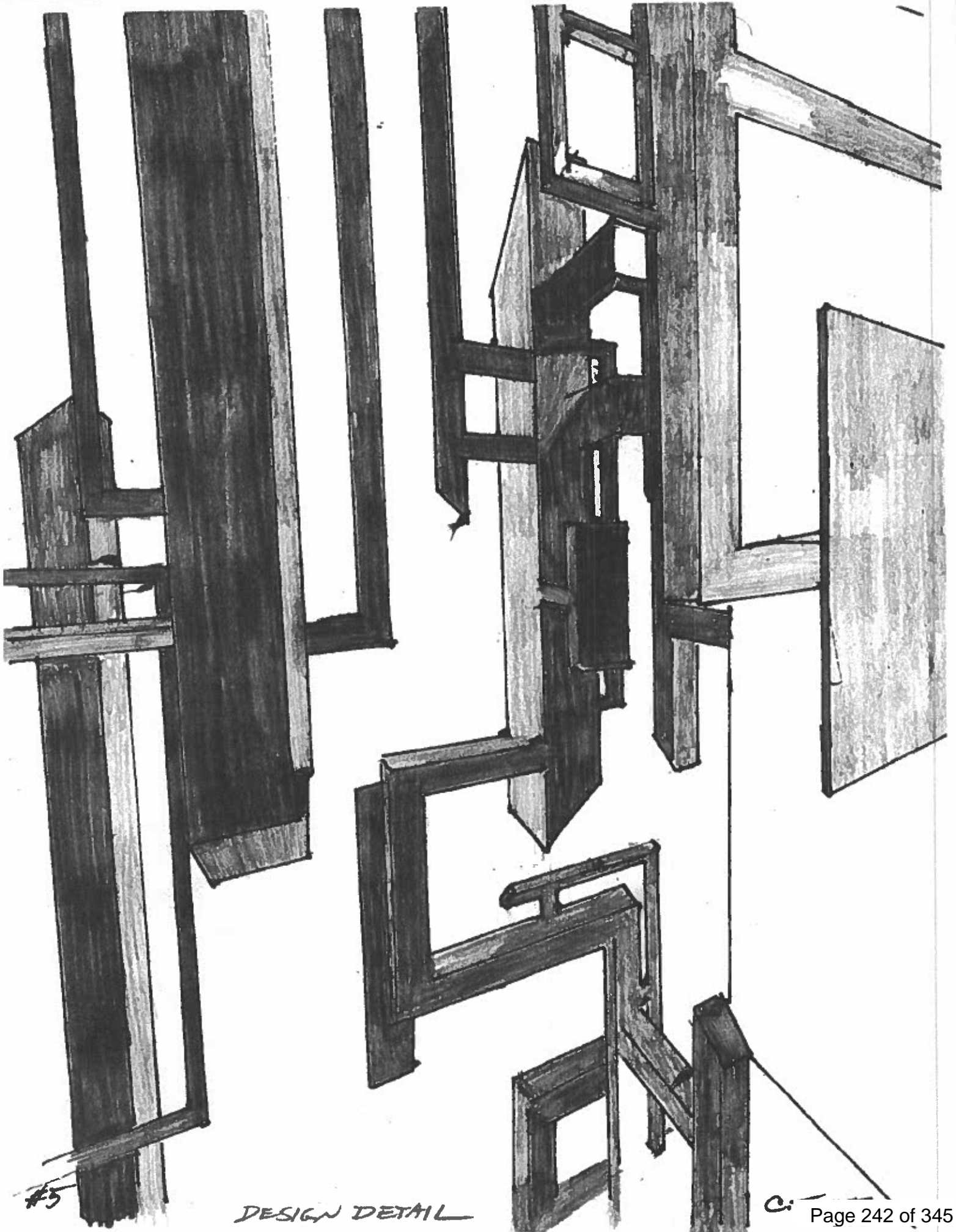
ORIGINAL SCULPTURE DESIGN  
"A COMMUNITY OF SHAPES"



#4

"A COMMUNITY OF SHAPES"

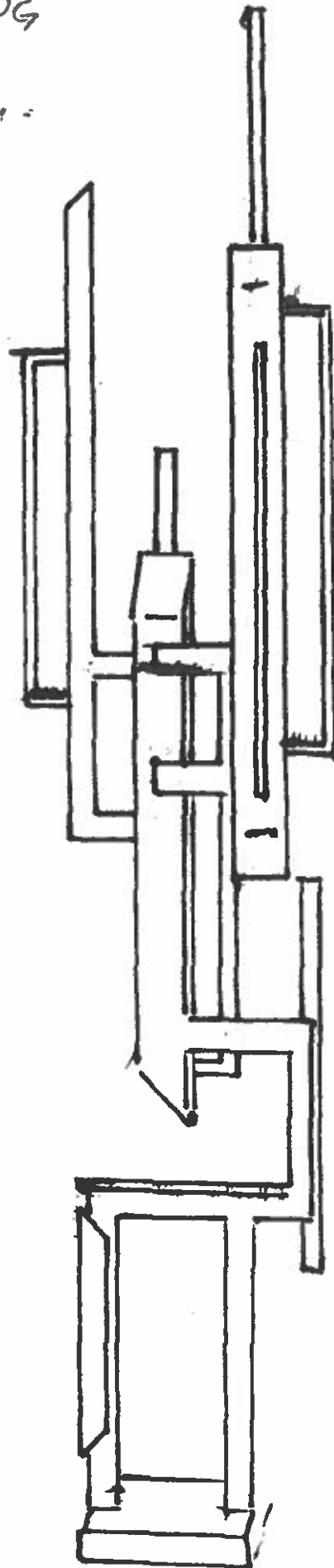




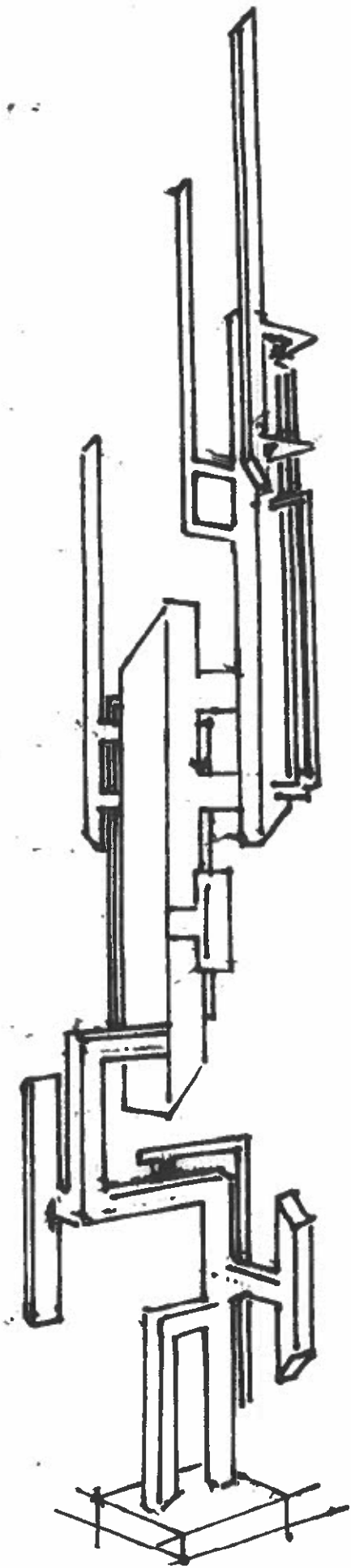
#5

DESIGN DETAIL

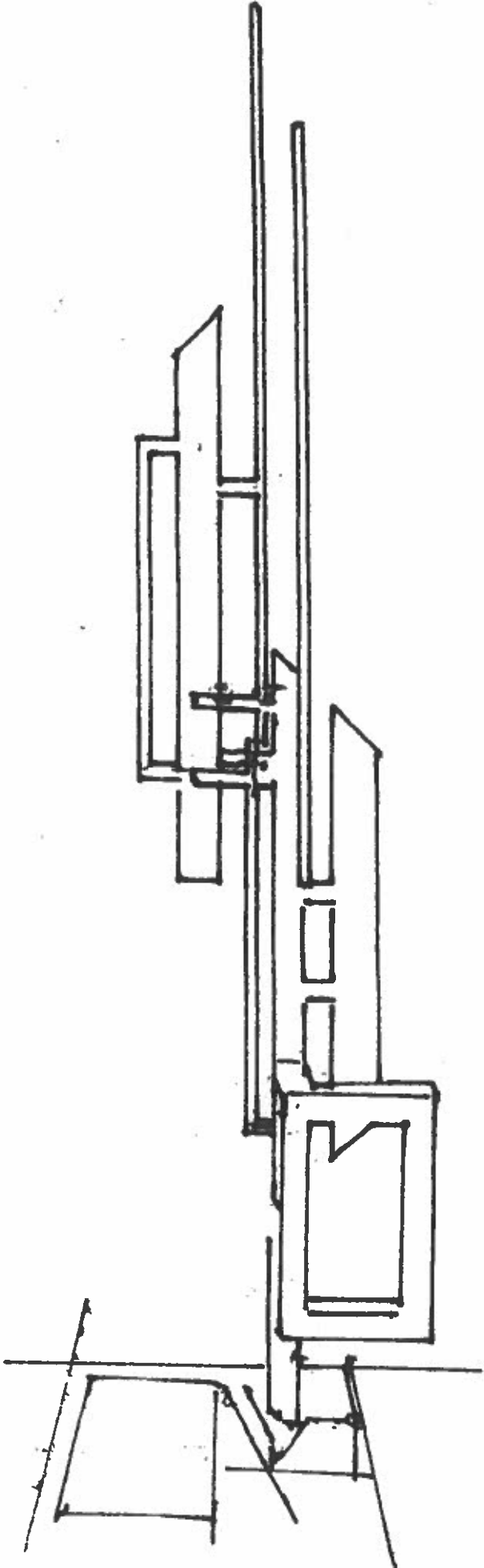
CONCEPT DRAWING  
#7



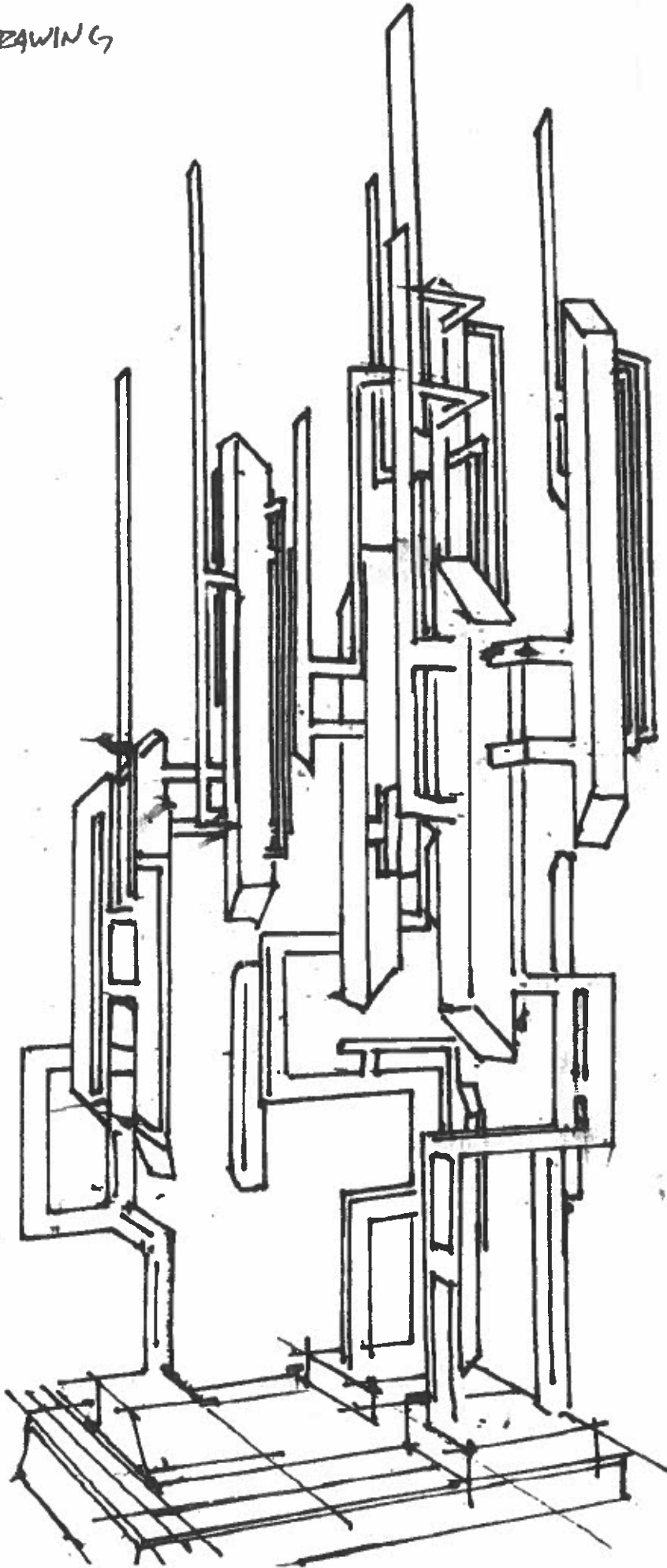
CONCEPT DRAWINGS  
#2



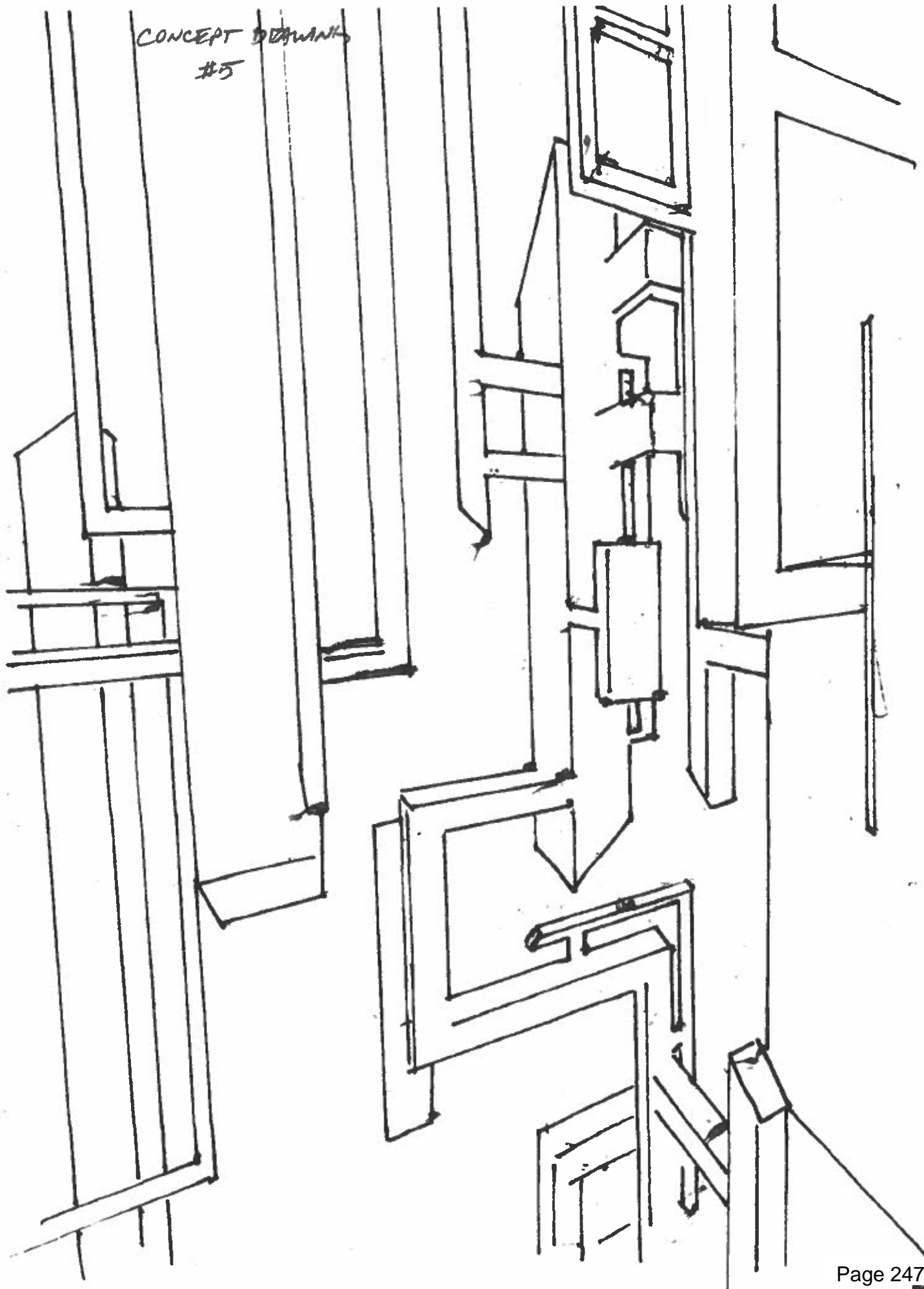
CONCEPT DRAWING  
#3



CONCEPT DRAWING  
#4



CONCEPT DRAWINGS  
#5



**Kelli Hoover**

---

**From:** Amazon.com <auto-confirm@amazon.com>  
**Sent:** Monday, January 9, 2023 1:26 PM  
**To:** Kelli Hoover  
**Subject:** Your Amazon.com order #111-4700591-7108265



## Order Confirmation

Hello Kelli,

Thank you for shopping with us. We'll send a confirmation when your items ship.

### Details

Order #111-4700591-7108265

Arriving:  
**Wednesday, January 11**

Ship to:  
**Kelli  
Jackson, MI**

[View or manage order](#)

**Order Total: \$101.72**

We hope to see you again soon.

**Amazon.com**

### Keep shopping for



Adir Mobile Blueprint  
Roll File...  
\$173.94 ✓prime



MEROKEETY Women's  
Long Sleeve V Neck...  
\$28.04 ✓prime

The payment for your invoice is processed by Amazon Payments, Inc. P.O. Box 81226 Seattle, Washington 98108-1226. If you need more information, please contact (866) 216-1075

By placing your order, you agree to Amazon.com's Privacy Notice and Conditions of Use. Unless otherwise noted, items sold by Amazon.com are subject to sales tax in select states in accordance with the applicable laws of that state. If your order contains one or more items from a seller other than Amazon.com, it may be subject to state and local sales tax, depending upon the seller's business policies and the location of their operations. [Learn more about tax and seller information.](#)

This email was sent from a notification-only address that cannot accept incoming email. Please do not reply to this message.

[Click here to report this email as spam.](#)

Jackson Public Arts Commission  
Martin Luther King Jr. Blvd Roundabout  
Sculpture

Project Details

**Table of contents:**

**Sculpture Specifications**

**Timeline**

**Budget / Payment Schedule**

**Insurance (example)**

**Site Specifications**

**Finished Sculpture Designs**

**Conceptual Sculpture Designs**

## Sculpture Specifications

### Process and Fabrication Description

The fabrication process or work plan is comprised of several process implemented at the same time. Everything starts at the drafting of the sculpture installation. From the initial design, the refinement and scaling of the design comes into place. Once that has been established, the process of scaling design follows. Upon completion of the finalized designs, fabrication commences. Materials, vendors and assistance will be engaged. Individual components will be fabricated and assembled into the final sculpture. In conjunction with this process, site visits and consultations with the JPAC team about the foundation and progress updates will occur as necessary. Design elements and weight determinations will be forwarded as the fabrication progresses. Once the fabrication process is completed, the sculptures undergo a finishing phase before the coating process.

During fabrication, the site foundation and preparation continues with advice and consultations with the contractors and city. After inspection and approval of the foundation and installation pad has been received from the city and JPAC representatives, transportation for delivery of the final pieces from the powder coater will be scheduled for delivery to the studio for final assembly and then proceed to the site. The sculptures will be delivered and installed under my supervision, in coordination with the City of Jackson Building and Engineering inspectors. Following MiOSHA regulations and procedures the sculptures will be installed. Collaborating with the JPAC team, suggestions for lighting the pieces, and final landscaping design is completed. A final check and polishing will occur before acceptance.

Jackson Public Arts Commission  
Martin Luther King Jr. Blvd-Roundabout Sculpture  
Project Committee

Timeline:

January 2023

Project Confirmation  
Insurance  
Contract  
Permits/Excavation (Foundation)  
Begin fabrication process

February

JPAC/MLKRS project updates (meetings-studio visits).  
Fabrication continues  
Site visit (confirm foundation specs).  
Attachment bolts with subgrade anchors.

March

JPAC/MLKRS project updates (site visits-logistics).  
Prepare and pouring of sculpture foundation/curing time  
Fabrication continues  
Metal finishing stage begins  
Above grade galvanized pedestals (fabricating).

April

Powdercoating/Exterior finishing of sculptures  
Site preparation

JPAC/MLKRS updates (finishing/installation/transportation).

April/May

Finishing/installation

Transport finished sculptures to site for installation.

Careful packing and securing of all related components and installation equipment.

Finished sculptures installed.

Final inspection and sign off

Project completion

Jackson Public Arts Commission  
Martin Luther King Jr. Blvd-Roundabout Sculpture  
Project Committee

**Budget:**

Permits,accounting,logistics and legal.	\$4500
Design,Artwork purchase,operating costs.	\$11,000
Materials,fabrication equipment,consumables.	\$5000
Installation,site preparation,labor.	\$4000
Transportation,outsourcing,ect.	\$2500
Equipment,specific tools required.	\$1000
Finishing process,galvanizing,powder coating.	
<b>Budget Grand Total:</b>	<b>\$30,000</b>

**Payment schedule:**

50% of total budget (\$15,000) is required to begin the fabrication and construction process.

25% of remaining balance (\$7500) will be required towards the halfway point of the project.

25% of the total budget which is the balance (\$7500) will be required upon completion of the project installation and agreement of JPAC and MLKRS Project Committee

This budget payment schedule has been made specifically for this project.

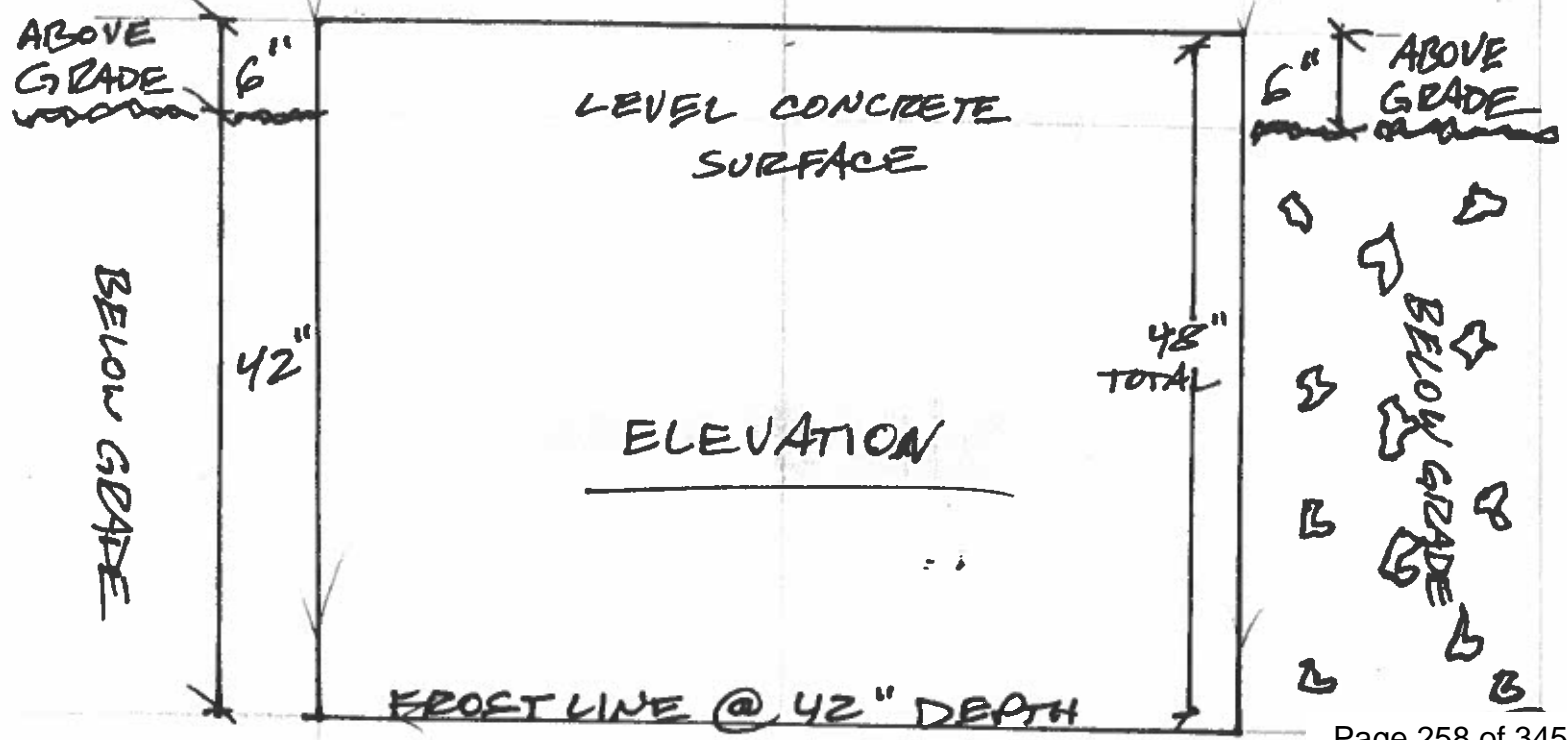
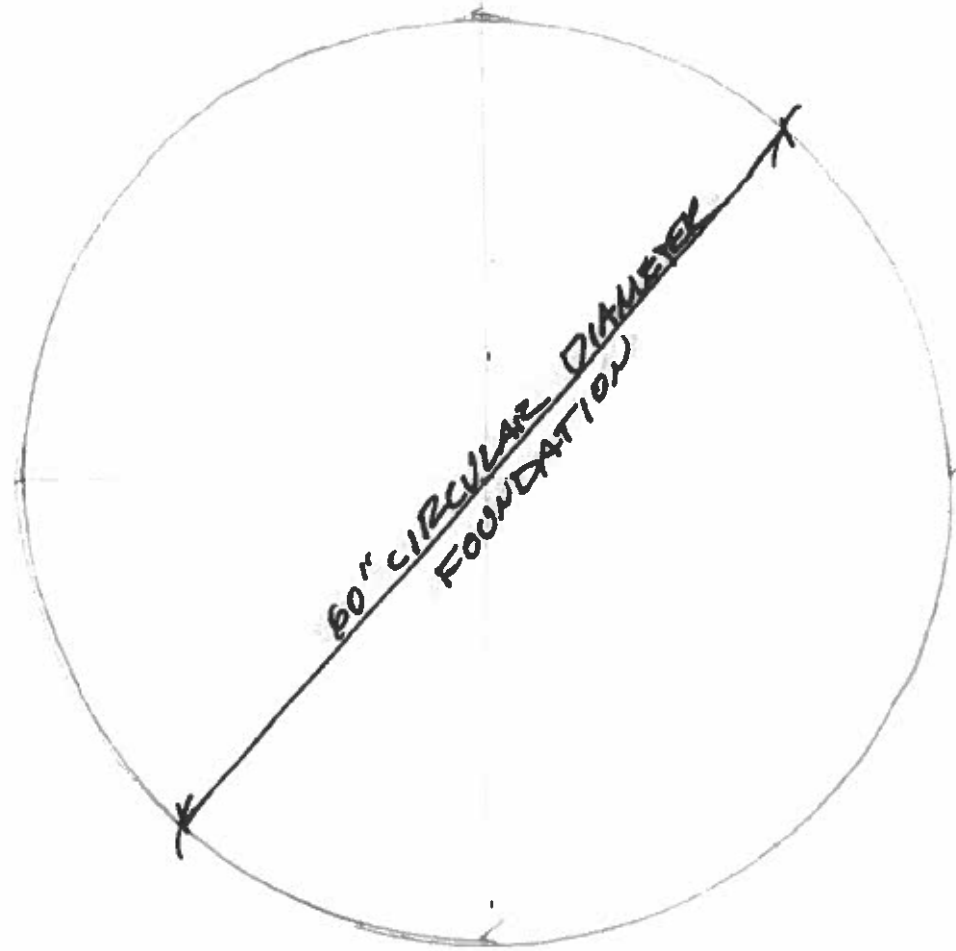
Thank you.





\* FOUNDATIONS  
↓  
DETAILS

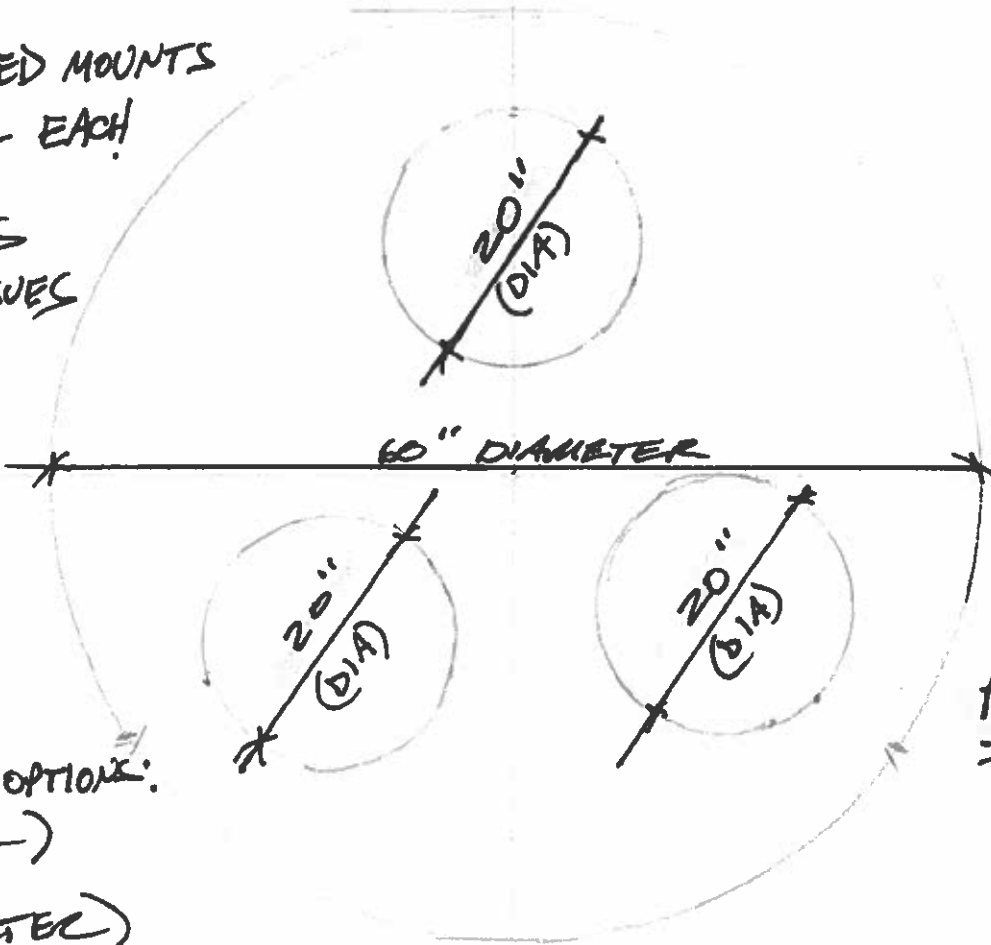
PLAN VIEW



③ GALVANIZED 1/4" THICK SCULPTURE PEDISTALS

\* GALVANIZED MOUNTS  
48" TALL EACH

\* ADDRESSES  
SAFETY ISSUES

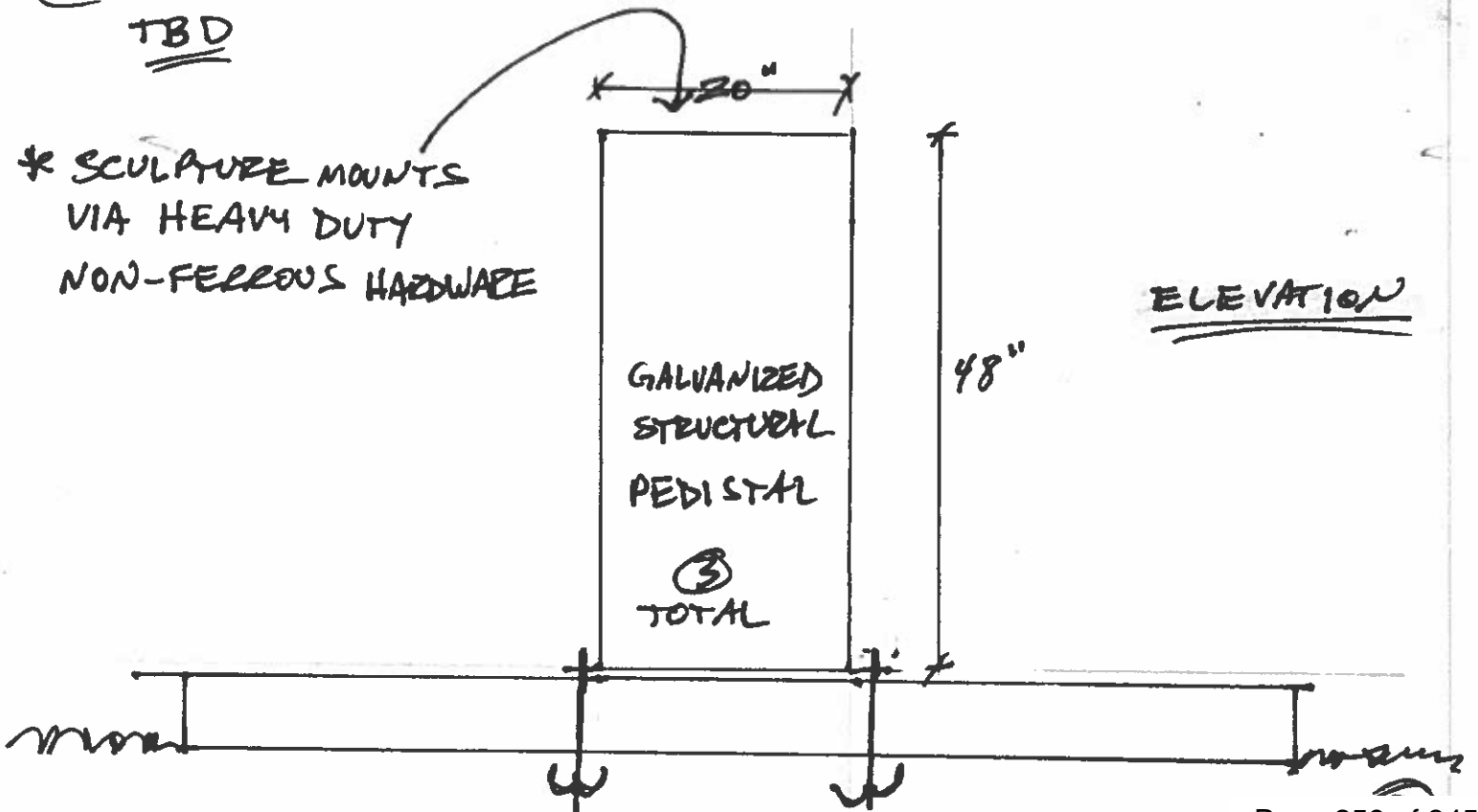


PLAN VIEW

\* LIGHTING OPTIONS:  
(CENTER)  
(PERIMETER)

TBD

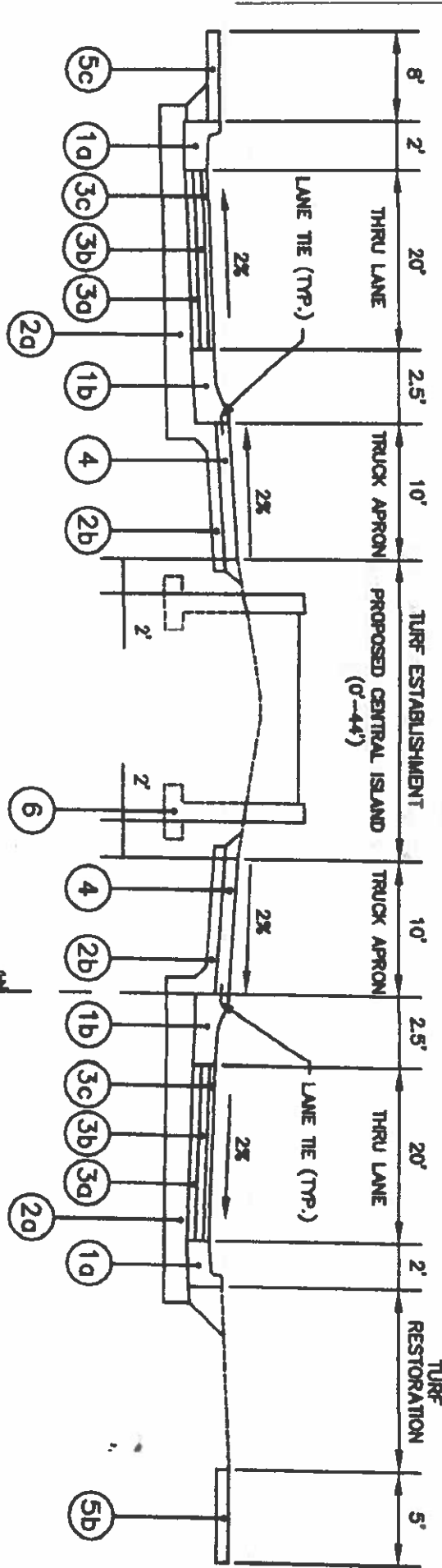
\* SCULPTURE MOUNTS  
VIA HEAVY DUTY  
NON-FERROUS HARDWARE



ELEVATION

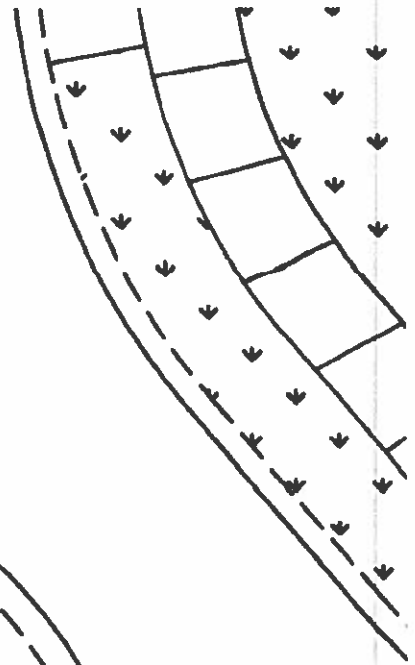
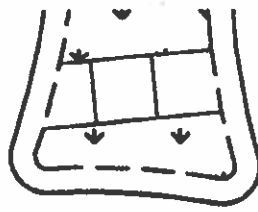
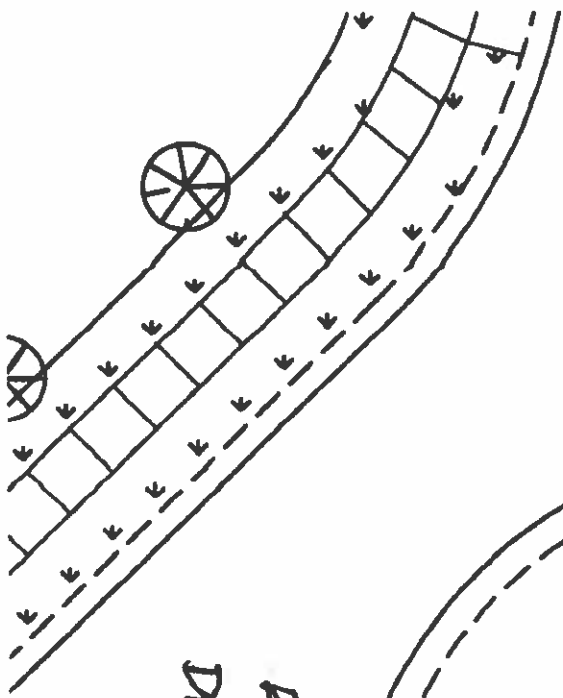
VARIABLES (66' - 201') ROW

DIAMETER

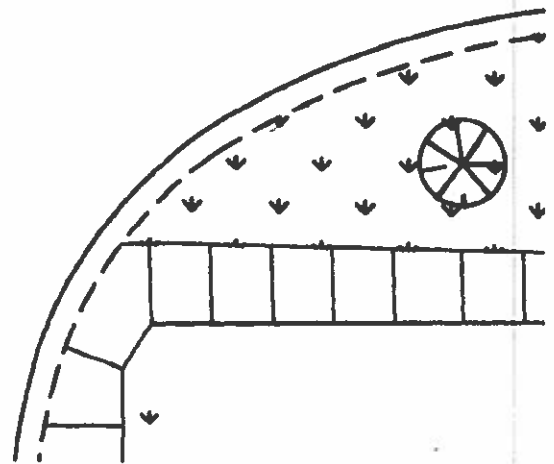
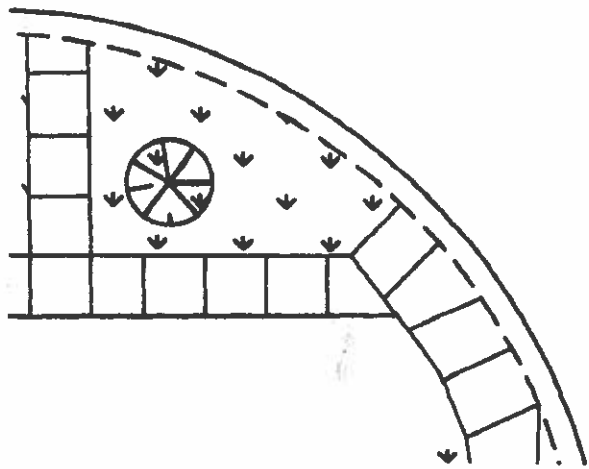
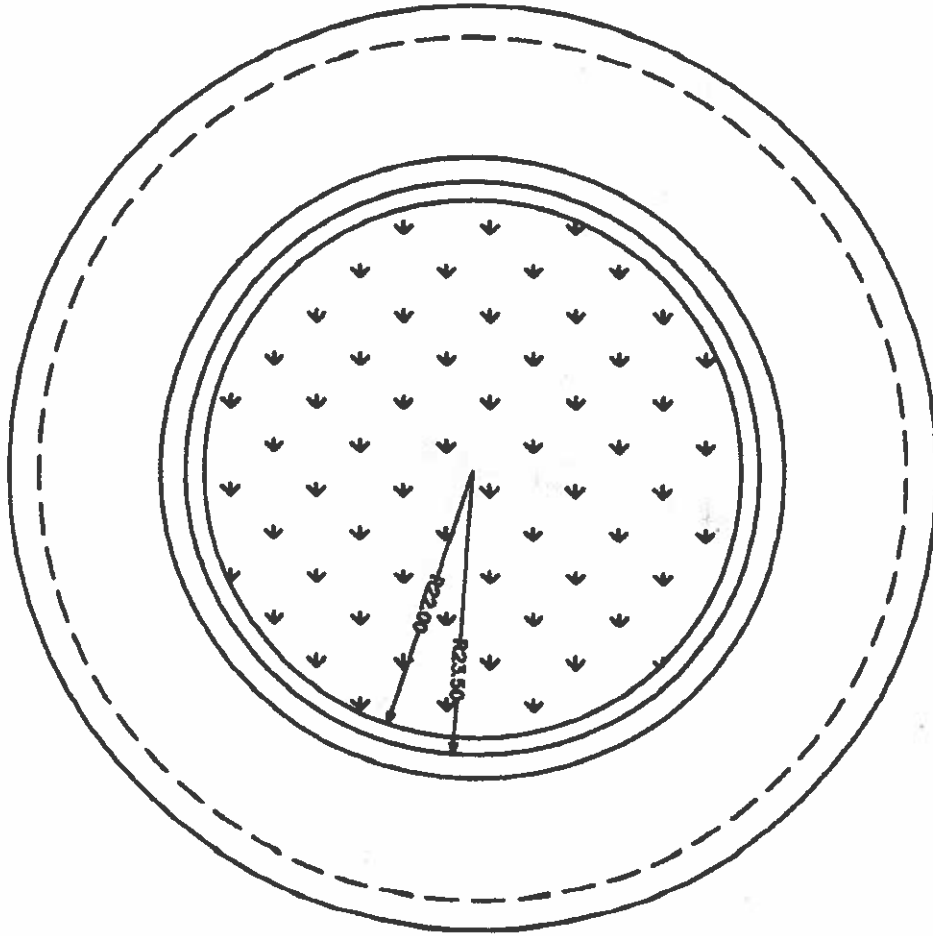


**FIGURE E**

TYPICAL CROSS SECTION OF PROPOSED CONSTRUCTION  
 STA 101+66 TO STA 102+85  
 ON MARTIN LUTHER KING JR DRIVE  
 STA 12+28 TO STA 13+64  
 ON MORRELL STREET

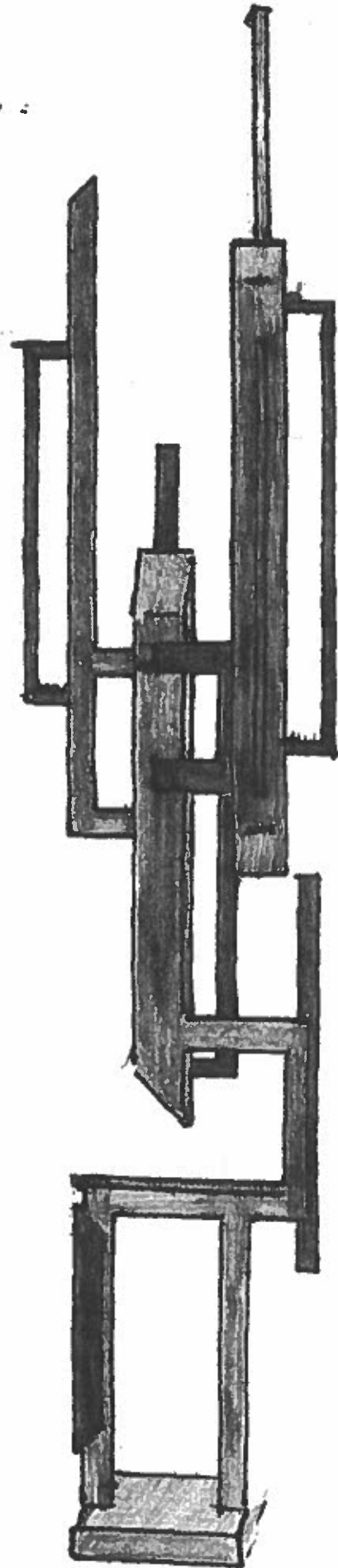


RADIUS = 22'  
 DIAMETER = 44'



ORIGINAL SCULPTURE DESIGN

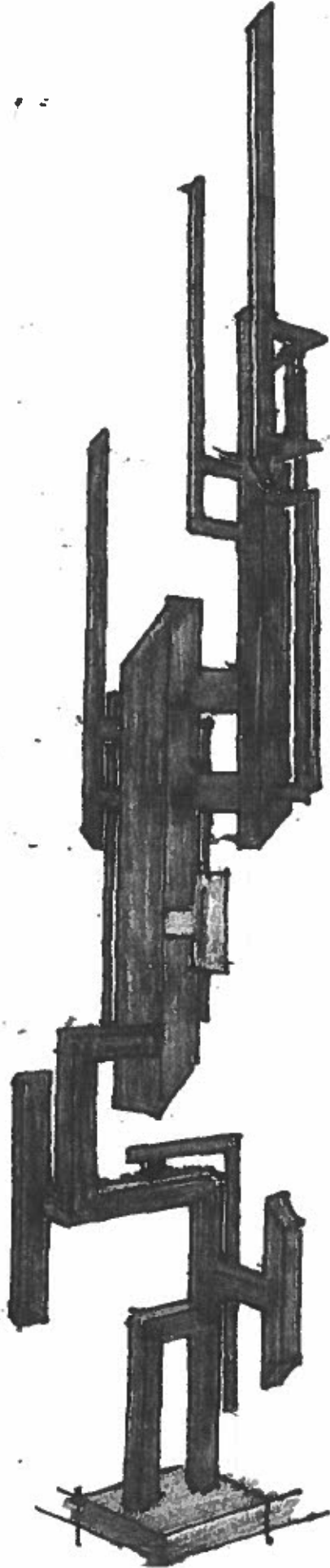
#7



C. TURNER

ORIGINAL SCULPTURE DESIGN

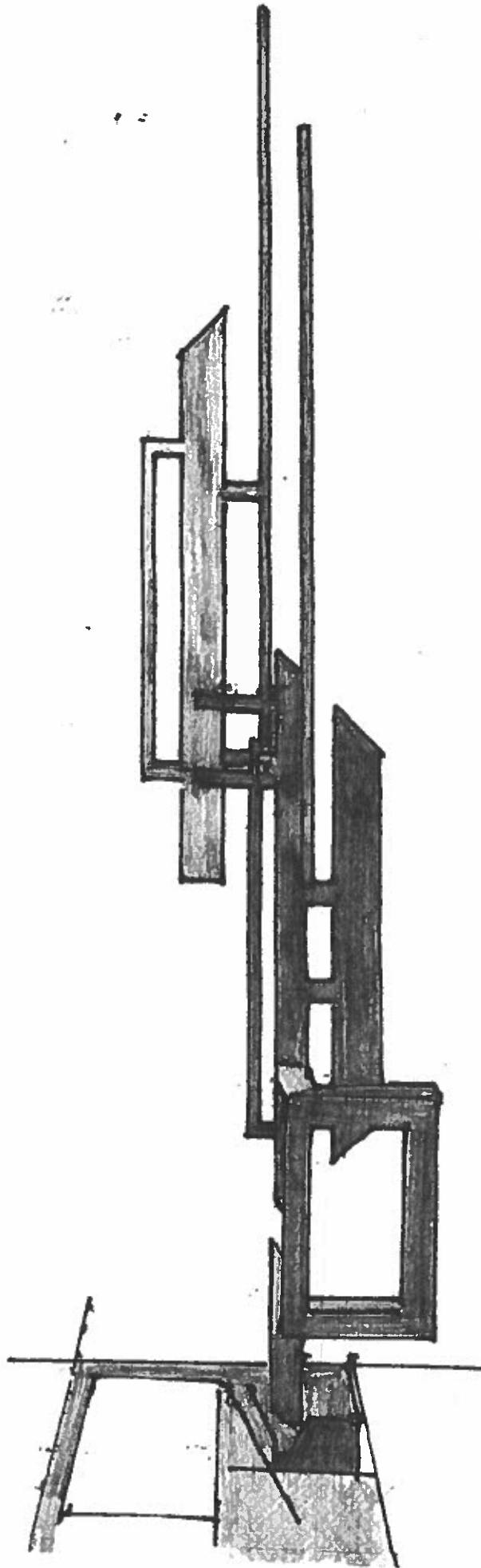
#2



C. TURNER  
2022

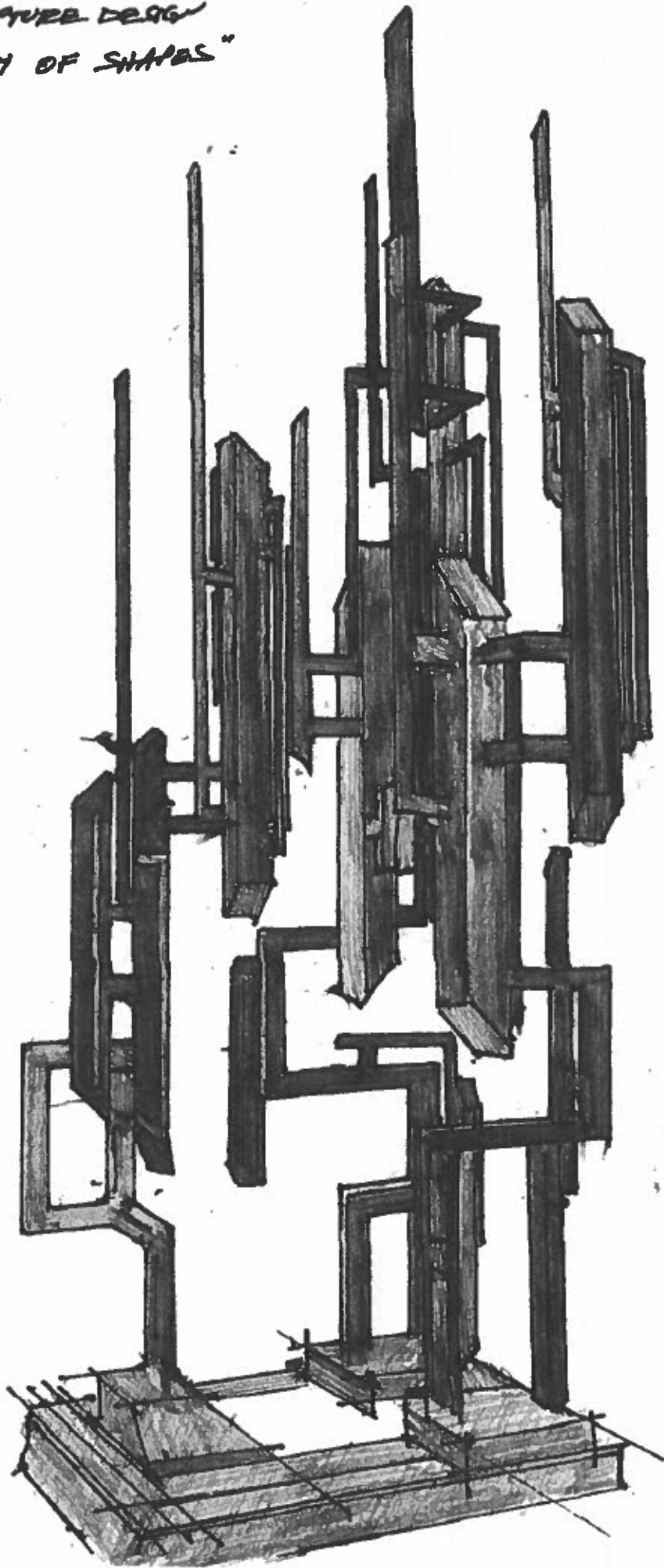
ORIGINAL SCULPTURE DESIGN

#3



C. TURNER  
2022

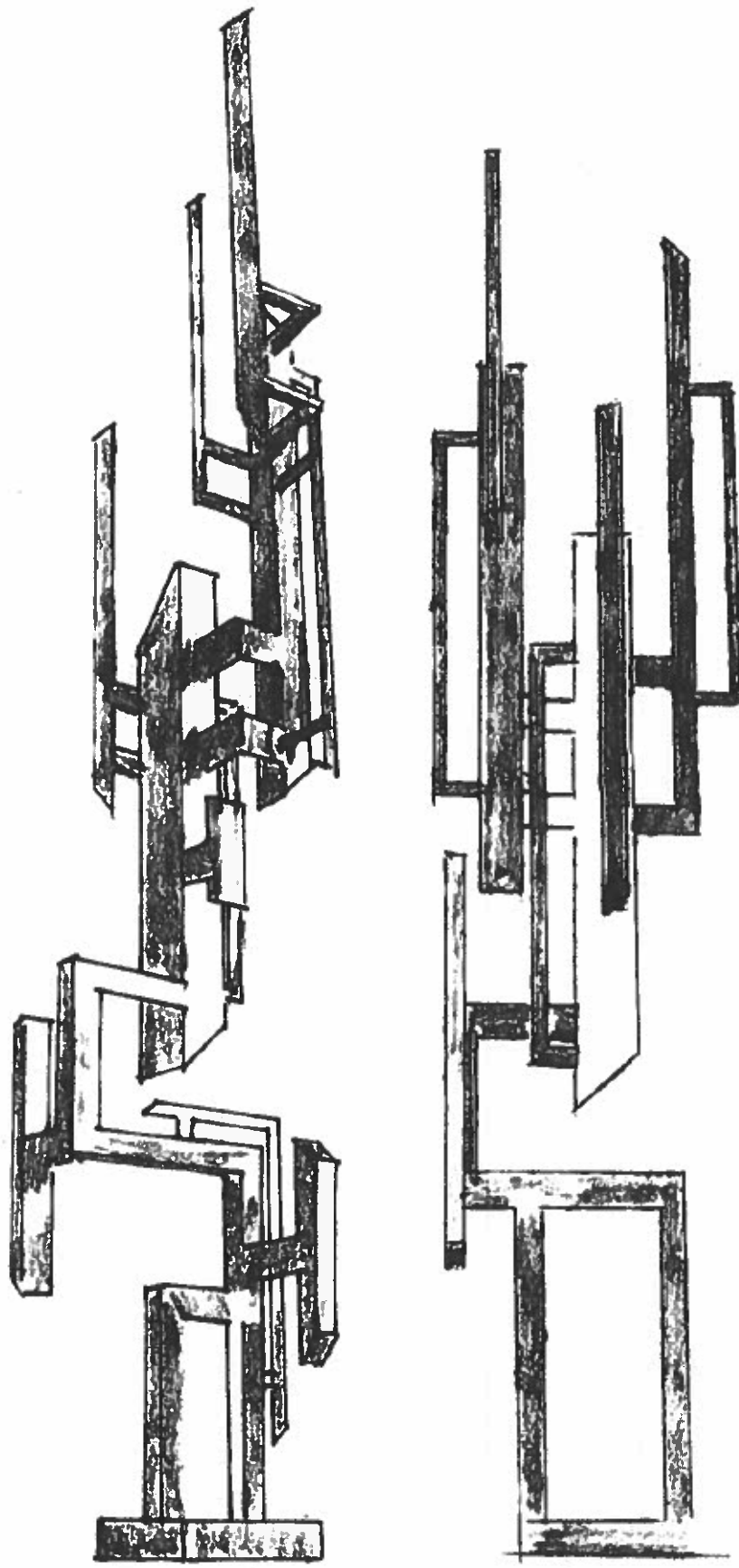
ORIGINAL SCULPTURE DESIGN  
"A COMMUNITY OF SHAPES"

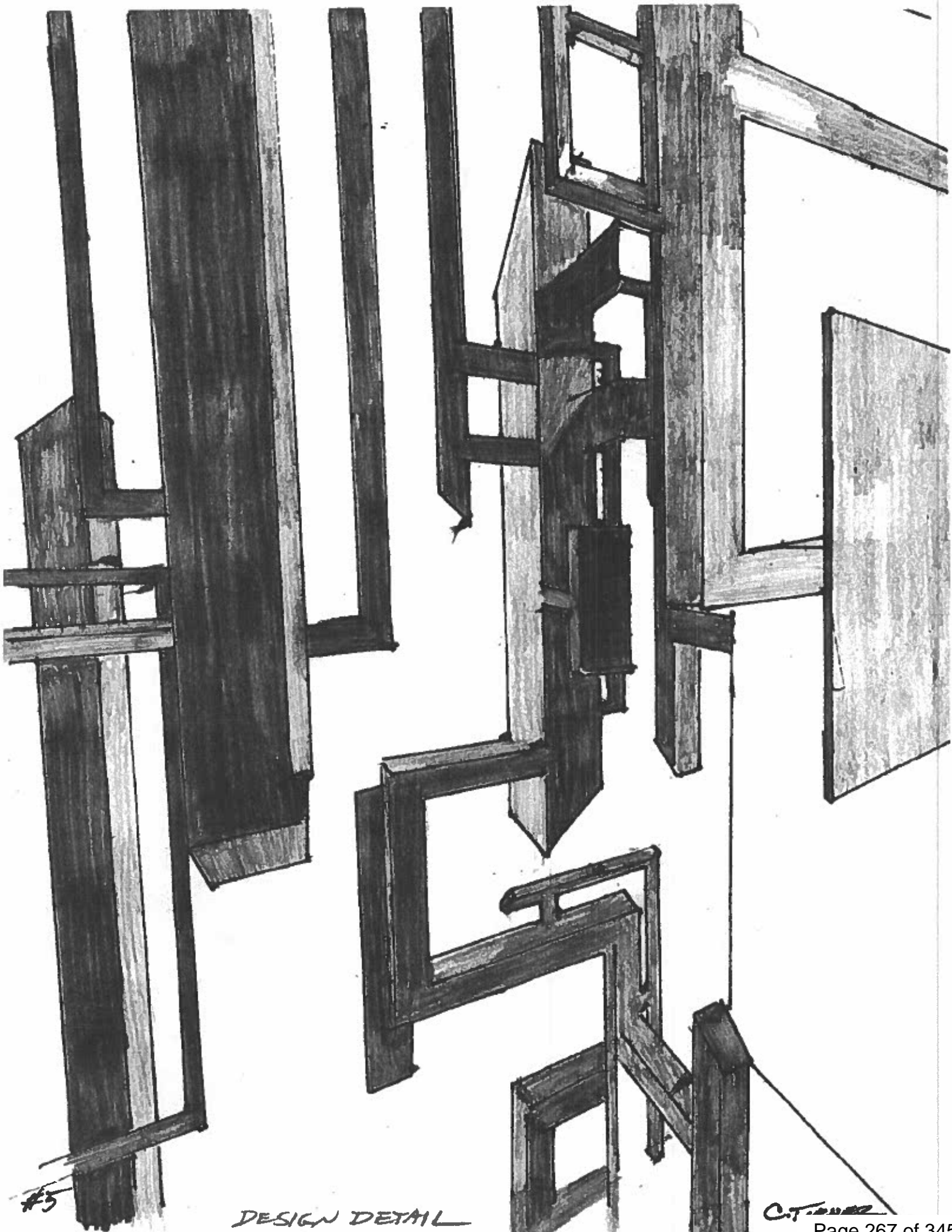


#4

C. TURNER

"A COMMUNITY OF SHAPES"



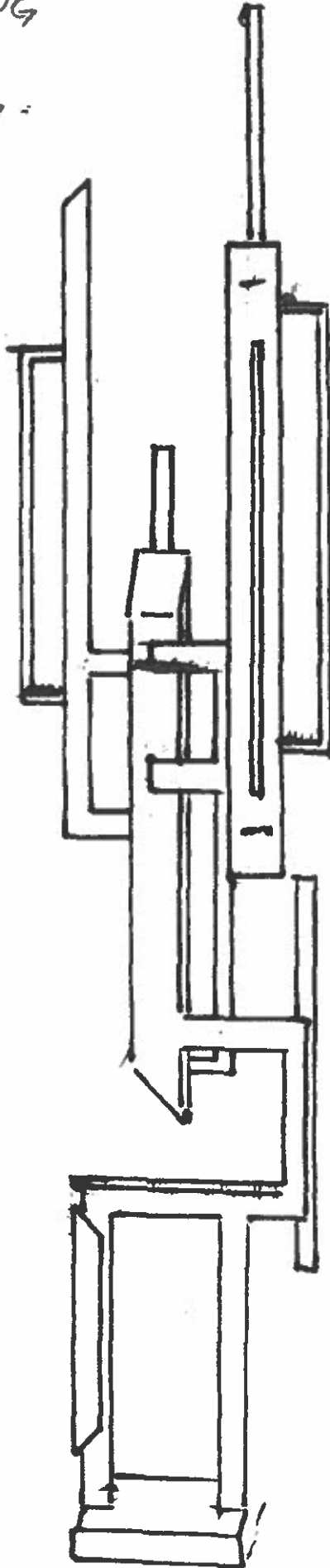


#5

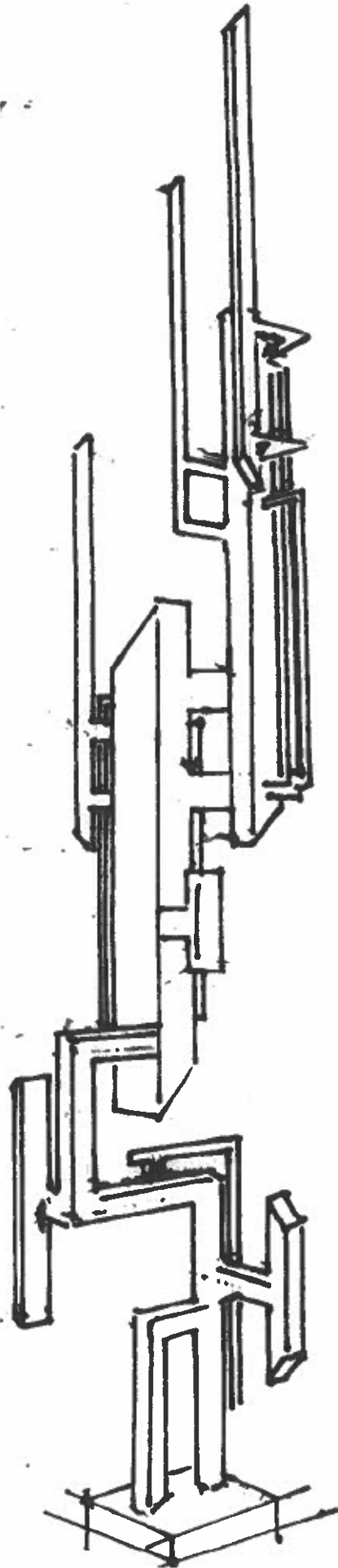
DESIGN DETAIL

C. J. [signature]

CONCEPT DRAWING  
#7

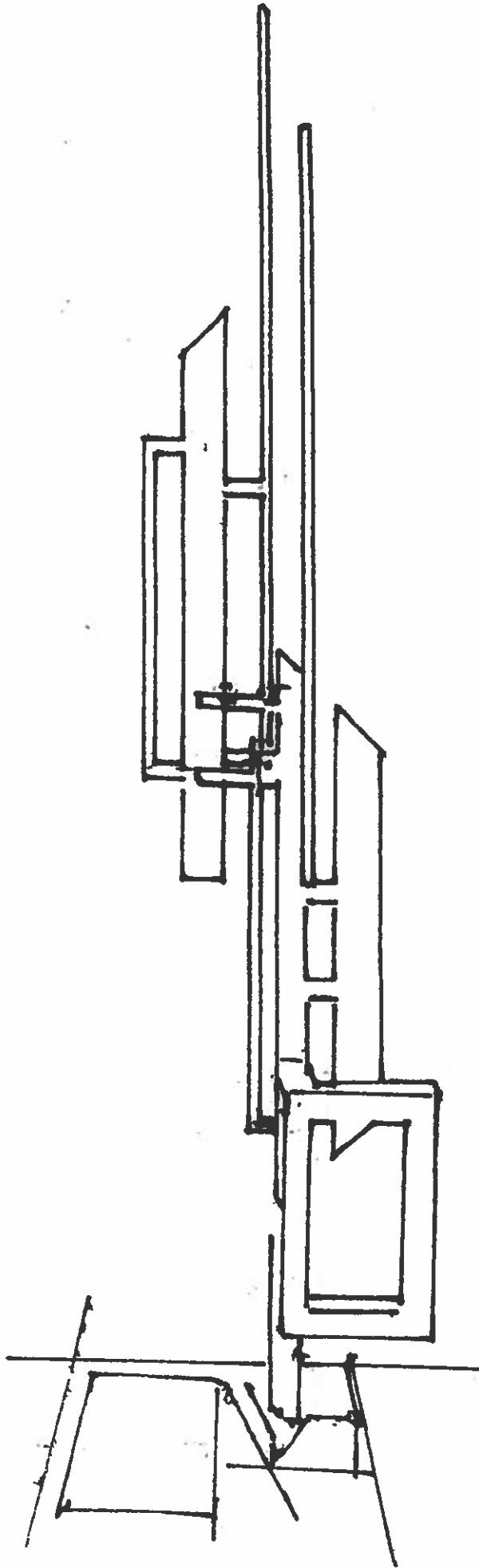


CONCEPT DRAWING  
#2

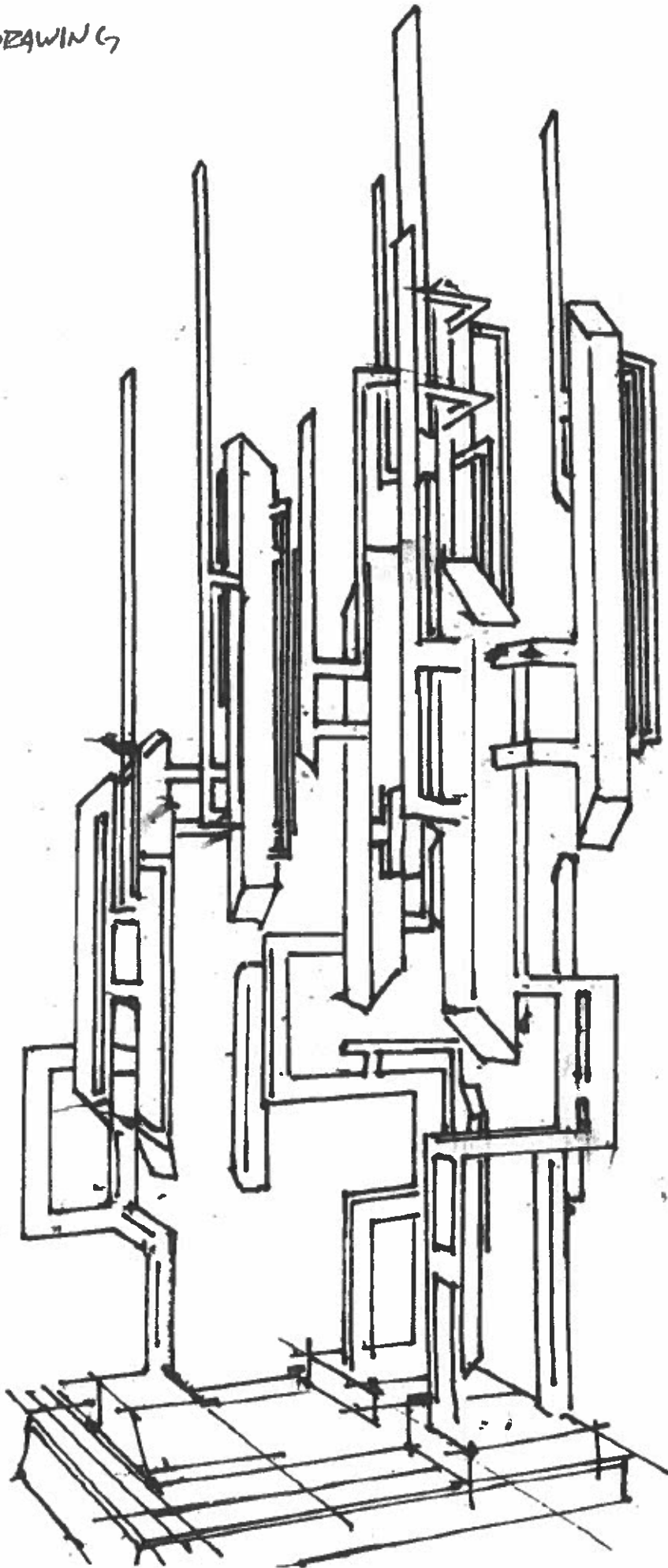


CT

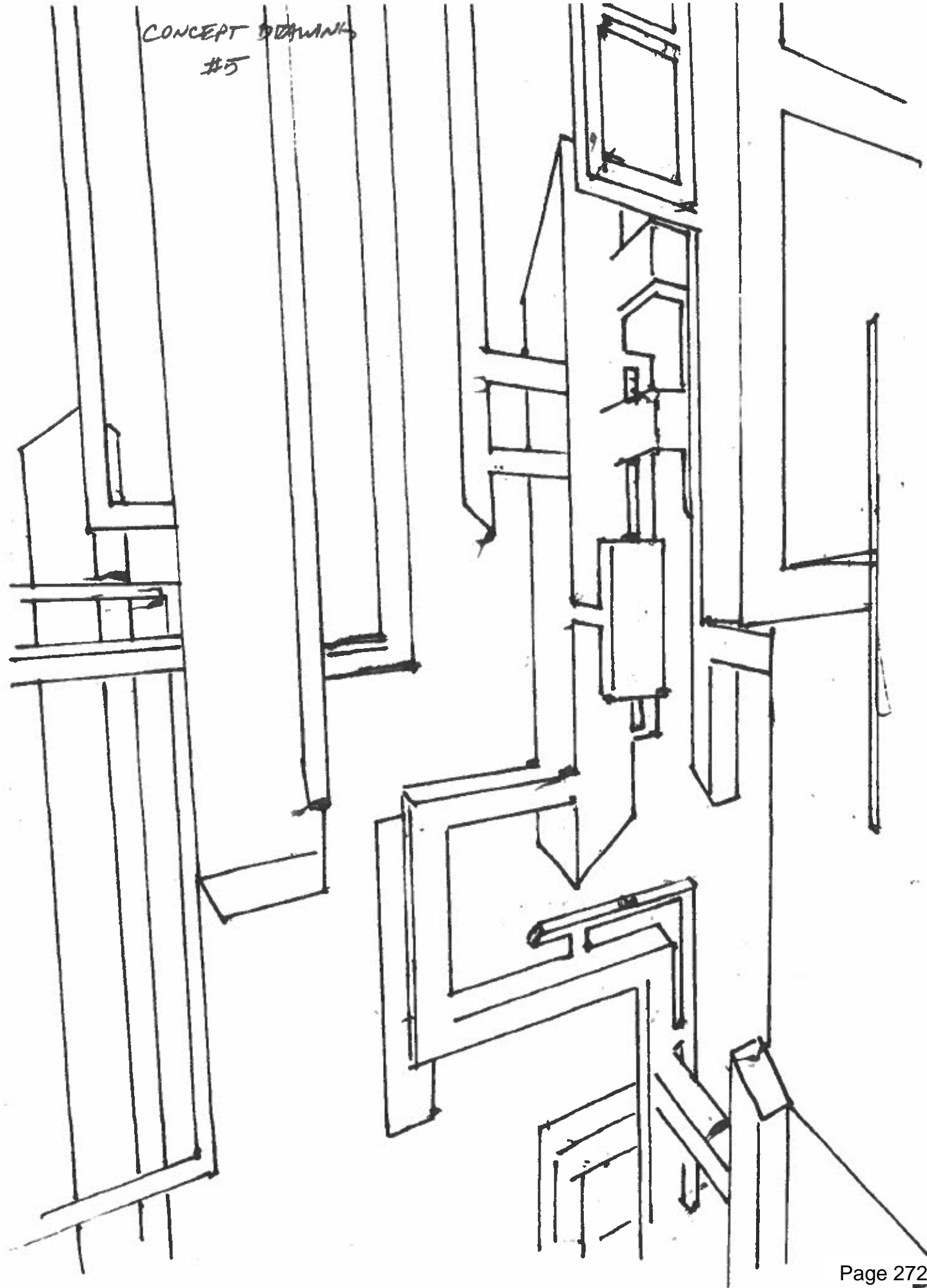
CONCEPT DRAWING  
#3



CONCEPT DRAWING  
#4



CONCEPT DRAWING  
#5



## Email Public Comment

## Kelli Hoover

---

**From:** Recreation  
**Sent:** Thursday, December 22, 2022 12:46 PM  
**To:** Kelli Hoover  
**Subject:** FW: Feedback for sculpture designs

**From:** C K <ckilian313@gmail.com>  
**Sent:** Thursday, December 22, 2022 11:26 AM  
**To:** Recreation <recreation@cityofjackson.org>  
**Subject:** Feedback for sculpture designs

Hello,

As a current Jackson resident in my opinion jackson is slowly rehabilitating its in-town neighborhoods. I believe Jackson is trying to make its community more appealing and valuable. I think the sculptures "A community of shapes" are beautiful and in my eye represents modern and sophisticated, new, future. Some of the others are almost childish in a way not ment like that but not a good representation.

Thank you for offering feedback from the community.

Click [here](#) to report this email as spam.

## Kelli Hoover

---

**From:** Recreation  
**Sent:** Thursday, December 22, 2022 12:46 PM  
**To:** Kelli Hoover  
**Subject:** FW: Feedback for sculpture designs

**From:** C K <ckilian313@gmail.com>  
**Sent:** Thursday, December 22, 2022 11:26 AM  
**To:** Recreation <recreation@cityofjackson.org>  
**Subject:** Feedback for sculpture designs

Hello,

As a current Jackson resident in my opinion jackson is slowly rehabilitating its in-town neighborhoods. I believe Jackson is trying to make its community more appealing and valuable. I think the sculptures "A community of shapes" are beautiful and in my eye represents modern and sophisticated, new, future. Some of the others are almost childish in a way not ment like that but not a good representation.

Thank you for offering feedback from the community.

Click [here](#) to report this email as spam.

## Kelli Hoover

---

**From:** Recreation  
**Sent:** Saturday, December 24, 2022 7:41 AM  
**To:** Kelli Hoover  
**Subject:** Fwd: MLK sculpture

Sent from my iPhone

Begin forwarded message:

**From:** Sky Rogers <skypilotrg@cs.com>  
**Date:** December 24, 2022 at 5:57:52 AM EST  
**To:** Recreation <recreation@cityofjackson.org>  
**Subject:** MLK sculpture  
**Reply-To:** Sky Rogers <skypilotrg@cs.com>

My choice for the MLK roundabout sculpture is 'A community of shapes'  
[Sent from the all new AOL app for Android](#)

Click [here](#) to report this email as spam.

## Kelli Hoover

---

**From:** Recreation  
**Sent:** Wednesday, December 28, 2022 3:09 PM  
**To:** Kelli Hoover  
**Subject:** Fwd: Sculpture Feedback

Sent from my iPhone

Begin forwarded message:

**From:** Chauntay <cah010692@gmail.com>  
**Date:** December 28, 2022 at 3:05:17 PM EST  
**To:** Recreation <recreation@cityofjackson.org>  
**Subject:** Sculpture Feedback

Hello,

I'd love to vote for the 3rd sculpture, "A Community of Shapes" to be constructed at the MLK roundabout. Please let me know if you need anything else.

Thank you,  
Chauntay Reynolds

Click [here](#) to report this email as spam.

## Kelli Hoover

---

**From:** Recreation  
**Sent:** Friday, December 30, 2022 8:47 AM  
**To:** Kelli Hoover  
**Subject:** Fwd: MLK drive roundabout

Sent from my iPhone

Begin forwarded message:

**From:** Samuel Tomlin <workahol2014@gmail.com>  
**Date:** December 30, 2022 at 5:54:59 AM EST  
**To:** Recreation <recreation@cityofjackson.org>  
**Subject:** MLK drive roundabout

I think the "A Community of Shapes" sculpture is appropriate because IT IS GENDER NEUTRAL, and non specific to any one group of people.

Click [here](#) to report this email as spam.

## Kelli Hoover

---

**From:** Recreation  
**Sent:** Monday, January 2, 2023 3:11 AM  
**To:** Kelli Hoover  
**Subject:** Fwd: Sculpture for MLK Roundabout

Sent from my iPhone

Begin forwarded message:

**From:** Emily Spiess <emilyspiess@gmail.com>  
**Date:** January 2, 2023 at 1:07:43 AM EST  
**To:** Recreation <recreation@cityofjackson.org>  
**Subject:** Sculpture for MLK Roundabout

"A Community Of Shapes."

Click [here](#) to report this email as spam.

## Kelli Hoover

---

**From:** Recreation  
**Sent:** Sunday, January 1, 2023 4:27 PM  
**To:** Kelli Hoover  
**Subject:** Fwd: MLK Roundabout

Sent from my iPhone

Begin forwarded message:

**From:** Recreation <recreation@cityofjackson.org>  
**Date:** December 25, 2022 at 2:50:39 PM EST  
**To:** William Powers <smokyyuwe@gmail.com>  
**Subject: Re: MLK Roundabout**

Thank you

Sent from my iPhone

On Dec 25, 2022, at 2:43 PM, William Powers <smokyyuwe@gmail.com> wrote:

Hello!

Just putting my two cents in, I would like "A Community of Shapes" by Chris Turner and Doug Jones. I think it would bring some individuality to the normal sculptures or works of art of that could be put up.

Have a nice holiday!

Click [here](#) to report this email as spam.

## Kelli Hoover

---

**From:** Recreation  
**Sent:** Sunday, January 1, 2023 4:27 PM  
**To:** Kelli Hoover  
**Subject:** Fwd: Sculpture Feedback

Sent from my iPhone

Begin forwarded message:

**From:** Recreation <recreation@cityofjackson.org>  
**Date:** December 28, 2022 at 3:08:43 PM EST  
**To:** Kelli Hoover <khoover@cityofjackson.org>  
**Subject:** Fwd: Sculpture Feedback

Sent from my iPhone

Begin forwarded message:

**From:** Chauntay <cah010692@gmail.com>  
**Date:** December 28, 2022 at 3:05:17 PM EST  
**To:** Recreation <recreation@cityofjackson.org>  
**Subject:** Sculpture Feedback

Hello,

I'd love to vote for the 3rd sculpture, "A Community of Shapes" to be constructed at the MLK roundabout. Please let me know if you need anything else.

Thank you,  
Chauntay Reynolds

Click [here](#) to report this email as spam.

## Kelli Hoover

---

**From:** Recreation  
**Sent:** Sunday, January 1, 2023 4:27 PM  
**To:** Kelli Hoover  
**Subject:** Fwd: MLK drive roundabout

Sent from my iPhone

Begin forwarded message:

**From:** Recreation <recreation@cityofjackson.org>  
**Date:** December 30, 2022 at 8:46:48 AM EST  
**To:** Kelli Hoover <khoover@cityofjackson.org>  
**Subject:** Fwd: MLK drive roundabout

Sent from my iPhone

Begin forwarded message:

**From:** Samuel Tomlin <workahol2014@gmail.com>  
**Date:** December 30, 2022 at 5:54:59 AM EST  
**To:** Recreation <recreation@cityofjackson.org>  
**Subject:** MLK drive roundabout

I think the "A Community of Shapes" sculpture is appropriate because IT IS GENDER NEUTRAL, and non specific to any one group of people.

Click [here](#) to report this email as spam.

# Open House Public Comment

**Martin Luther King Jr.  
Roundabout Sculpture  
Community Input Form**

Artist: Doug + Chris

Piece: \_\_\_\_\_

Comments: The gold  
is a nice  
choice  
and out for  
me

**Martin Luther King Jr.  
Roundabout Sculpture  
Community Input Form**

Artist: Doug Jones + Chris Turner

Piece: A Community of Shapes

Comments: \_\_\_\_\_  
It represents to me  
that like the community,  
it's an intergration of  
diverse parts

**Martin Luther King Jr.  
Roundabout Sculpture  
Community Input Form**

Artist: Chris Turner + Doug Jones

Piece: Community of shapes

Comments: Like the way  
the pieces can be  
viewed from all angles.  
continuation of energy +  
perspectives

**Martin Luther King Jr.  
Roundabout Sculpture  
Community Input Form**

Artist: Doug Jones + Chris Turner

Piece: A community of shapes

Comments: I would recommend  
just one of the sculptures.  
My favorite was the tallest  
one (the mock-up on the table)  
I love the blue - correlates  
back to the City of Jackson  
works well with all!

**Martin Luther King Jr.  
Roundabout Sculpture  
Community Input Form**

Artist: \_\_\_\_\_

Piece: Community of Shapes

Comments: Add lights  
of chosen

\_\_\_\_\_  
\_\_\_\_\_  
\_\_\_\_\_  
\_\_\_\_\_

**Martin Luther King Jr.  
Roundabout Sculpture  
Community Input Form**

Artist: Doug Jones & Chris Tucke

Piece: Community of Shapes

Comments: Bold

\_\_\_\_\_  
\_\_\_\_\_  
\_\_\_\_\_

# **Ken Thompson**

- **Original Request for Art Application**
- **Interviewed against 12 other artist**
- **Finalist application and submission**
- **Attached emailed Public input copies**
- **Attached Open House Public input copies**

# **FLATLANDERS**

## **SCULPTURE SUPPLY & ART GALLERIES**

11993 East U.S. 223, Blissfield, MI 49228

517.486.4591

[www.flatlandersculpture.com](http://www.flatlandersculpture.com)

October 27, 2022

City of Jackson  
Parks and Recreation Director  
JPAC Advisory Committee  
Jackson, Michigan

Dear Selection Committee,

Public sculpture projects appeal to me because they present the opportunity to enhance and change environments. As well as, their availability to reach many more viewers from broader demographics as opposed to artwork displayed in a gallery or museum. It is my feeling that most people would like to experience art but are intimidated by the facades that house it. Whereas a public venue allows the viewers to deal with art in a more comfortable and less threatening setting.

As for execution and fabrication of a project, I have a 15,000 square foot facility (former car dealership) that is fully equipped for metal fabrication, glass casting, bronze casting and stone carving. Along with over forty-five years of experience as a working sculptor, I employ eight very competent full-time technicians to assist me with my projects. In addition, I have three architects and two engineers that I have worked with extensively and draw upon their expertise as needed.

Please feel free to contact me should you require additional information and thank you for making this opportunity possible.

Sincerely,  
Kenneth M. Thompson, DFAhc, MLS/S

enclosure(s)

## **Artist Statement and Approach**

**Kenneth M. Thompson**

**I have always had a fascination with buildings and bridges, as well as, the columns, posts, beams and arches that support them. I come to this world from a tradition of craftsmanship.**

**I prefer to use materials that convey strength. I have always felt that good art should be well made and that there is no excuse for poor craftsmanship.**

**I see each sculpture as a '*clean sheet of paper*' that presents new opportunities to discover solutions. Beyond content and suitability, my sculpture concentrates on the fundamental issues of form and how negative space defines it, as well as, the techniques employed to create it.**

**Professional References**

**Kenneth M. Thompson**

**Mark Folk  
Executive Director  
Arts Commission of Greater Toledo  
1838 Parkwood, Suite 120  
Toledo, OH 43624-1059  
(419) 254-2787  
mfolk@acgt.org**

**Tami Miller, Curator  
Krasl Art Center  
707 Lake Blvd  
St Joseph, MI 49085  
(269) 983-0271  
tmiller@krasl.org**

**Sr. Peg Albert, OP, President  
Siena Heights University  
1247 East. Siena Heights Drive  
Adrian, MI 49221  
517-263-0731  
palbert@sienaheights.edu**

**Dr. Dan Phelan, President  
Jackson College  
2111 Emmons Road  
Jackson, MI 49201  
517-787-0800  
phelandanielj@jccmi.edu**

**Kenneth M. Thompson**  
11993 East US Highway 223, Blissfield, MI 49228  
(517)486-4591 flatlandersculpture@netzero.net

**Image List of Selected Projects**

01. Title: **Ottawa Park Amphitheater Arch** 2021  
Location: Ottawa Park, Toledo, OH  
Size: 4'0 x 13'6 x 18'6  
Materials: Painted steel and aluminum  
Project cost: \$55,000.00
  
02. Title: **Light-up Sylvania Donor Recognition Sculpture** 2021  
Location: Downtown Sylvania, OH  
Size: 6'0 x 6'0 x 11'6  
Materials: Acrylic, aluminum and stainless steel  
Project cost: \$14,500.00
  
03. Title: **ProMedica Hickman Hospital** 2020  
Location: Main Entrance, Adrian, MI  
Size: 2'0 x 6'6 x 7'0  
Materials: Corten steel and limestone  
Project cost: \$11,500.00
  
04. Title: **ProMedica Hickman Hospital** 2020  
Location: Dining Plaza, Adrian, MI  
Size: 2'0 x 2'0 x 11'0 (three columns)  
Materials: Granite, stainless steel and steel  
Project cost: \$25,000.00
  
05. Title: **Henry Ford Allegiance Hospital Handprint Plaza** 2019-20  
Location: Jackson, MI  
Size: 20'0 x 22'0  
Materials: Cast glass, cast aluminum and grout  
Cost: \$32,000.00
  
06. Title: **Kingsley Condominiums** 2019  
Location: Ann Arbor, MI  
Size: 2'0 2'0 x 8'0 to 12'6 (five columns)  
Materials: Stainless steel and steel  
Project cost: \$42,000.00
  
07. Title: **Centennial Arch** 2019  
Location: Siena Heights University, Adrian, MI  
Size: 10'6 x 10'6 x 21'6  
Materials: Stainless steel, SAR acrylic and cast bronze  
Project cost: \$125,000.00
  
08. Title: **Column, Block and Base, Two** 2018  
Location: Henry Ford Allegiance Health, Jackson, MI  
Size: 8'0 x 8'0 x 16'6  
Materials: Aluminum, Corten steel and granite  
Project cost: \$85,000.00

## **Kenneth M. Thompson**

Flatlanders Sculpture Supply

11993 East U.S. Highway 223, Blissfield, MI 49228 (517) 486-4591

E-mail: [flatlandersculpture@netzero.net](mailto:flatlandersculpture@netzero.net) Websites: [www.kenthompsonsculpture.com](http://www.kenthompsonsculpture.com) [www.flatlandersculpture.com](http://www.flatlandersculpture.com)

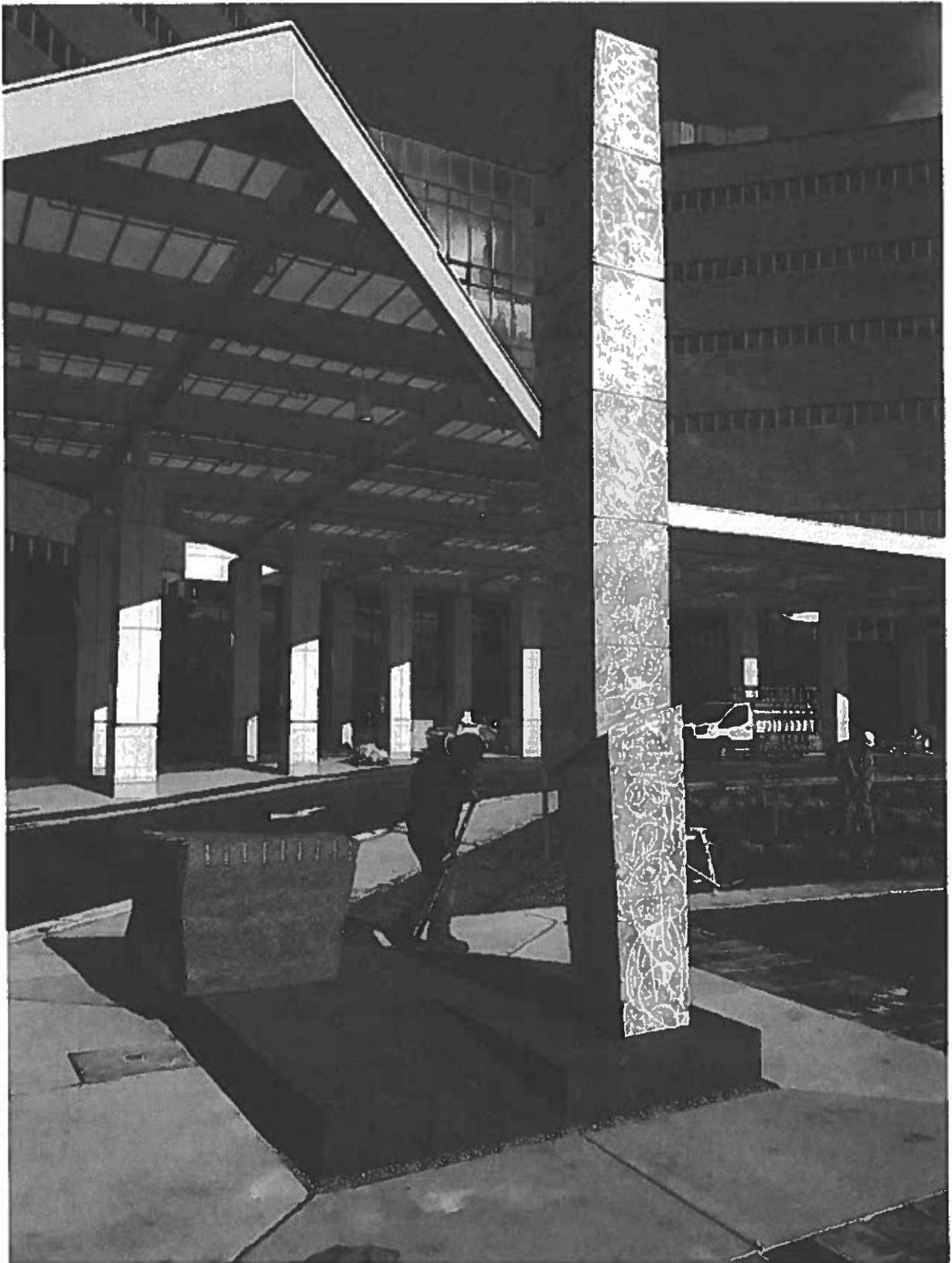
### **Public Sculpture Commissions**

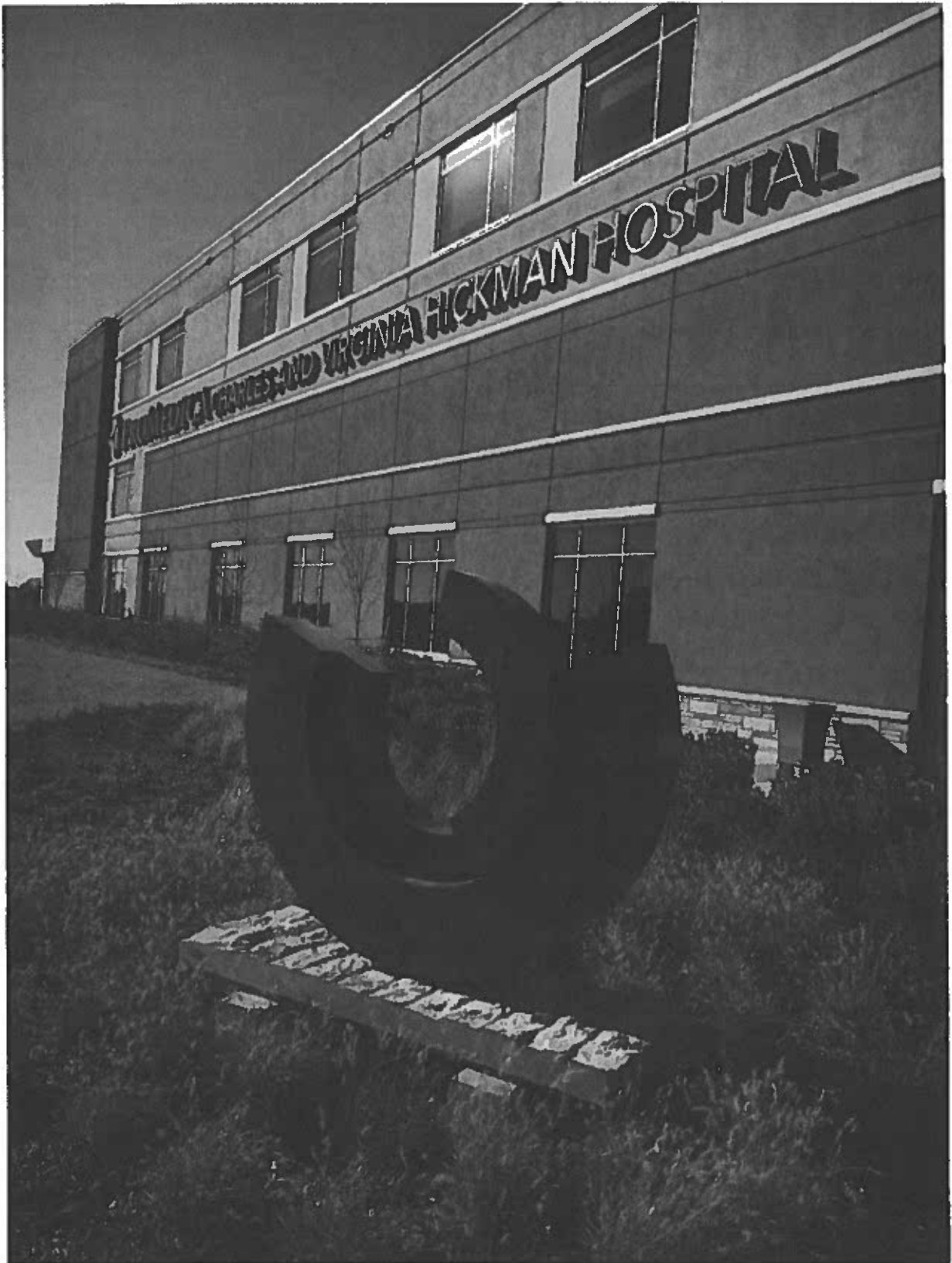
2022	Steele Way Arch, City of Adrian, MI (completion winter '22)
2022	Steib Road Gateway, Tecumseh, MI (completion winter '22)
2022	Luther Home of Mercy, Williston, OH (completion fall '22)
2022	Two Columns for Fostoria, City of Fostoria, OH
2021	University of St. Francis, Fort Wayne, IN
2021	Ottawa Park Amphitheater Sculpture, Toledo, OH
2021	Light-up Sylvania Sculpture, Sylvania, OH
2021	City of Lancaster, OH
2020	Henry Ford Allegiance Hospital Handprint Plaza, Jackson, MI
2020	ProMedica Hickman Hospital, Adrian, MI
2019	Kingsley Condominiums, Ann Arbor, MI
2019	Tecumseh High School Sculpture Garden, Tecumseh, MI
2019	Junction Park Sculptures, Toledo, OH
2018-2019	Centennial Mall Sculpture, Siena Heights University, Adrian, MI
2018-2020	Henry Ford Allegiance Hospital, Jackson, MI
2018	Ureel Wall Relief, Port Huron, MI
2016	Ella Sharp Museum of Art and History, Jackson, MI
2016	Auburn, Cord, Duesenberg Museum, Auburn, IN
2015-2017	Walker Building, Jackson College, Jackson, MI
2015-2016	Sullivan's Entry Gates, Manchester, MI
2015	Riverwalk, City of Port Huron, MI
2014-2015	Saline District Library, Saline, MI
2014	Krasl Art Center, St. Joseph, MI
2014	Bonita Springs Arts Center, Bonita Springs, FL
2014	St. Ignatius Catholic Church, Oregon, OH
2014	Ella Sharp Museum of Art and History, Jackson, MI
2013	Purdue University, West Lafayette, IN
2013	Krasl Art Center, St. Joseph, MI
2012	Krutch Park Sculpture, City of Knoxville, TN
2012	Wolfe Center, Bowling Green State University, Bowling Green, OH
2012	Purdue University, West Lafayette, IN
2012	Brewster Foundation, Topeka, KS
2012	Slippery Rock University, Slippery Rock, PA
2011	North Whiting Arch, Jackson Community College, Jackson, MI
2009-2010	Hogan Sculpture Project, Alma College, Alma, MI
2008-2010	Trilobite Project, Sylvania, OH
2009	CMS Energy, Jackson River Walk, Jackson, MI
2009	Ella Sharp Museum of Art and History, Jackson, MI
2008-2009	Alumni Plaza, University of Toledo, Corpus Christi University Parish, Toledo, OH
2008	Siena Heights University, Adrian, MI
2006-2008	Viking Heritage Project, Jackson High School, Jackson, MI
2007	ITC Building, Jackson Community College, Jackson, MI
2007	Whiting Hall, Jackson Community College, Jackson, MI
2006	Ford/Canton Center Project, Canton, MI
2005-2006	Toledo School for the Arts, Toledo, OH
2004-2006	Korean War Memorial, Civic Center Mall, Toledo, OH
2004-2005	Rotary Centennial Project, Sylvania, OH
2004-2005	St. Jude Catholic Church, Toledo, OH
2003-2005	Florida Atlantic University, Port St. Lucie, FL
2004	University of St. Francis, Fort Wayne, IN
2004	Siena Heights University, Adrian, MI
2004	Prince of Peace Church, West Bloomfield, MI
2003	Village of Douglas, Bayou Park, Douglas, MI
2002-2003	St. Patrick Catholic Church, Bryan, OH

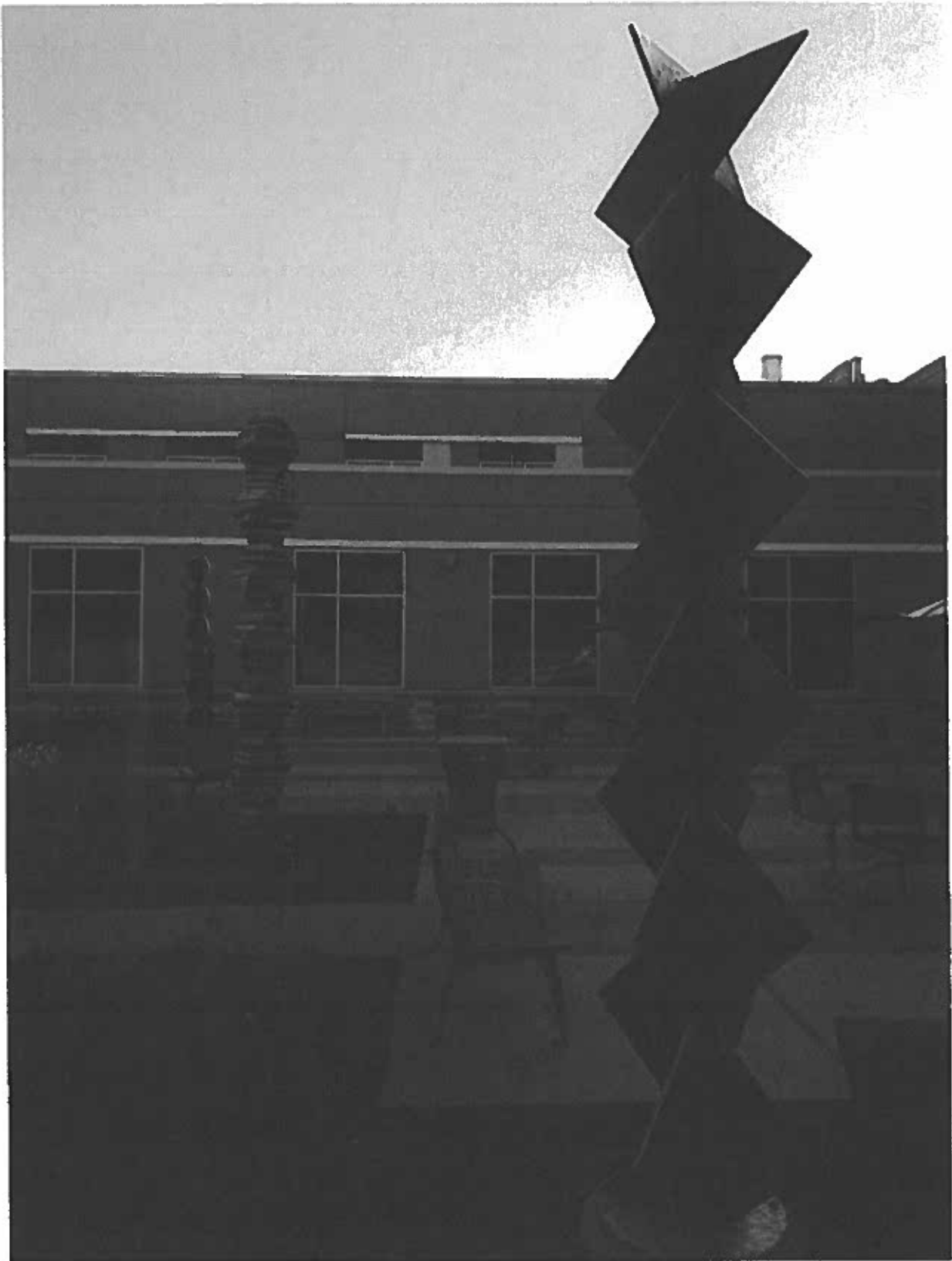


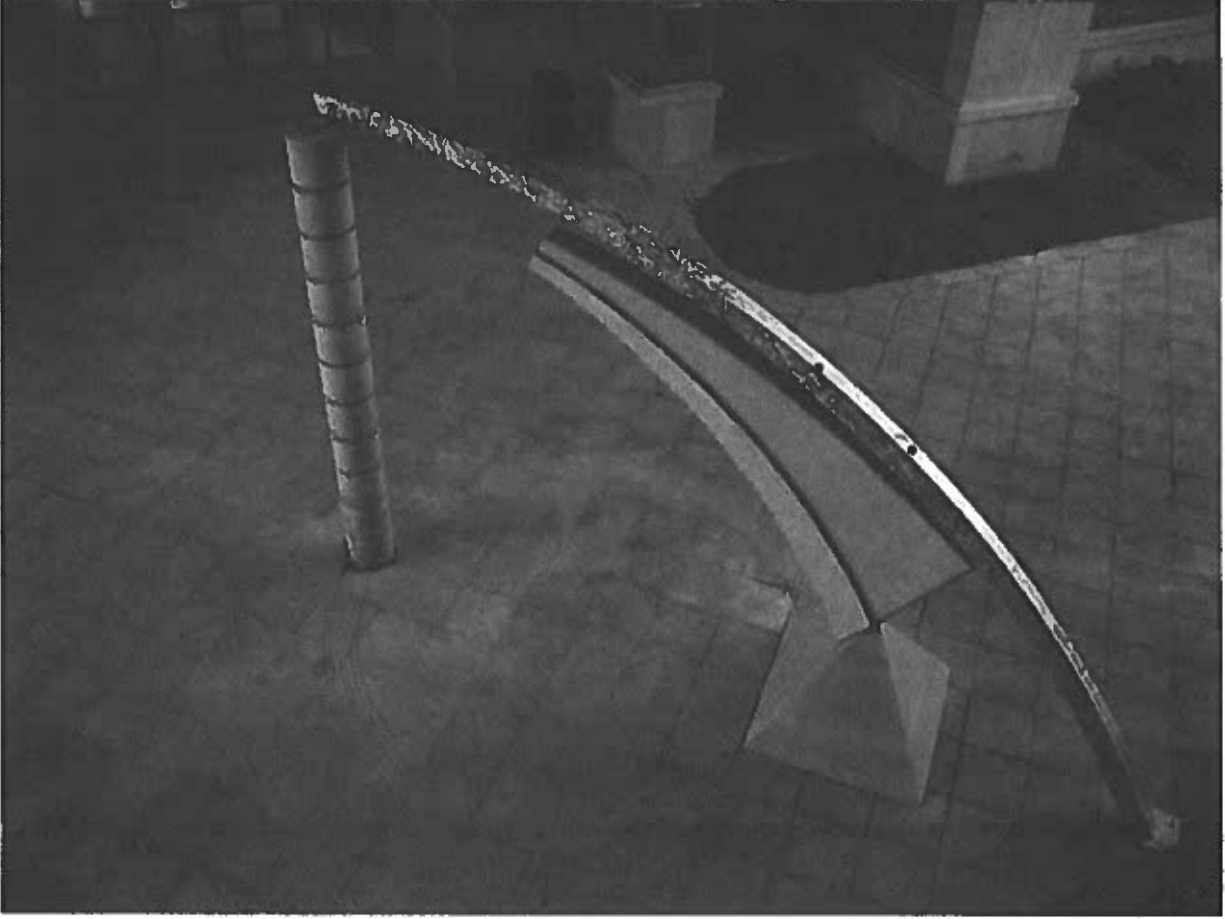


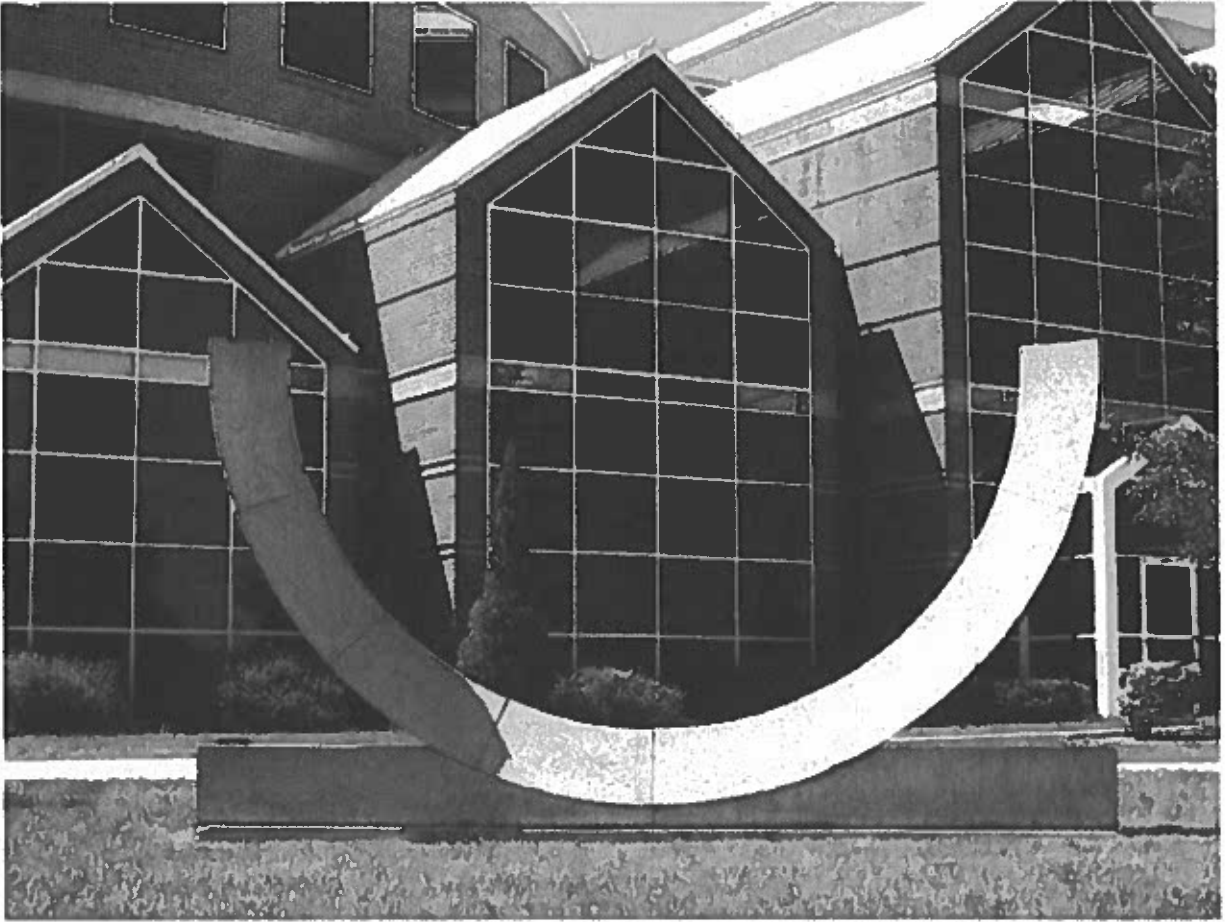






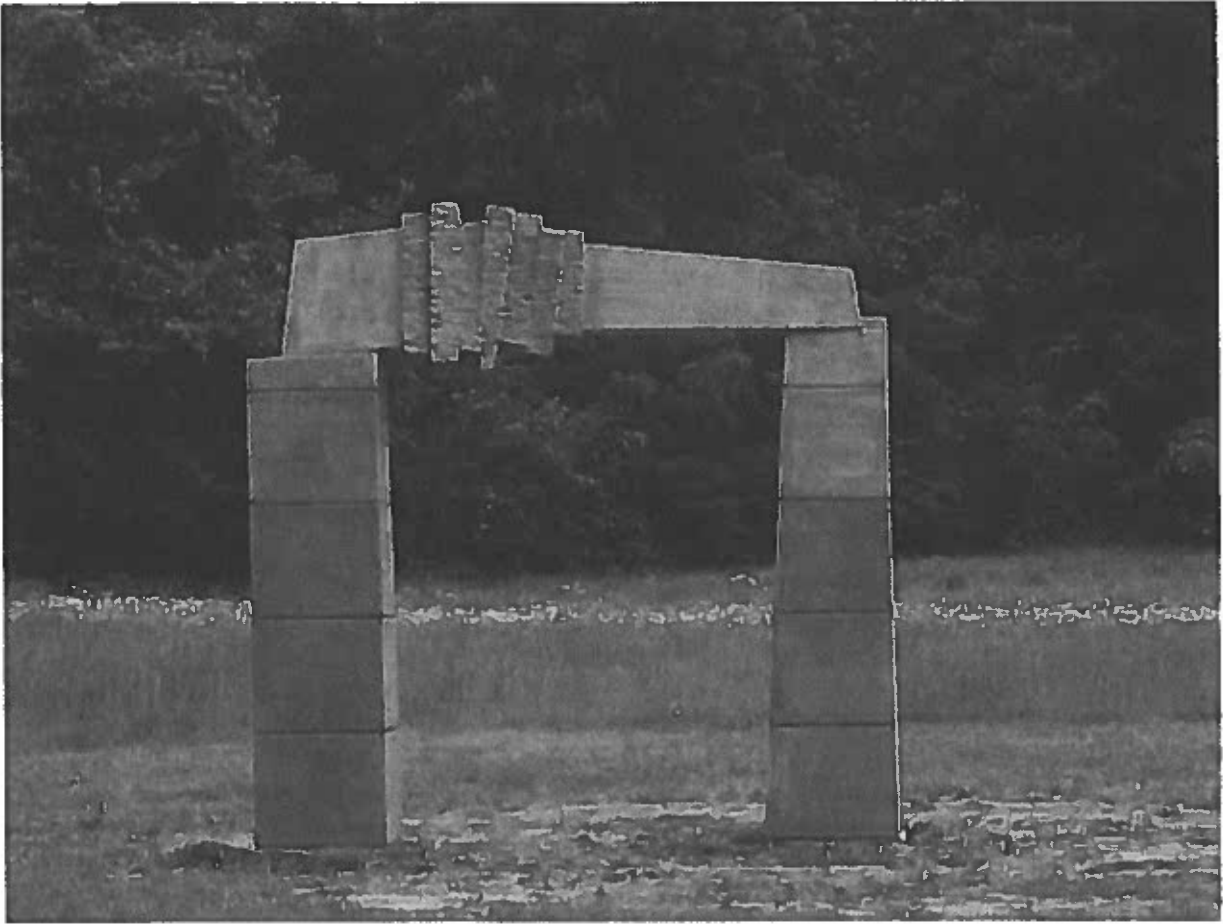


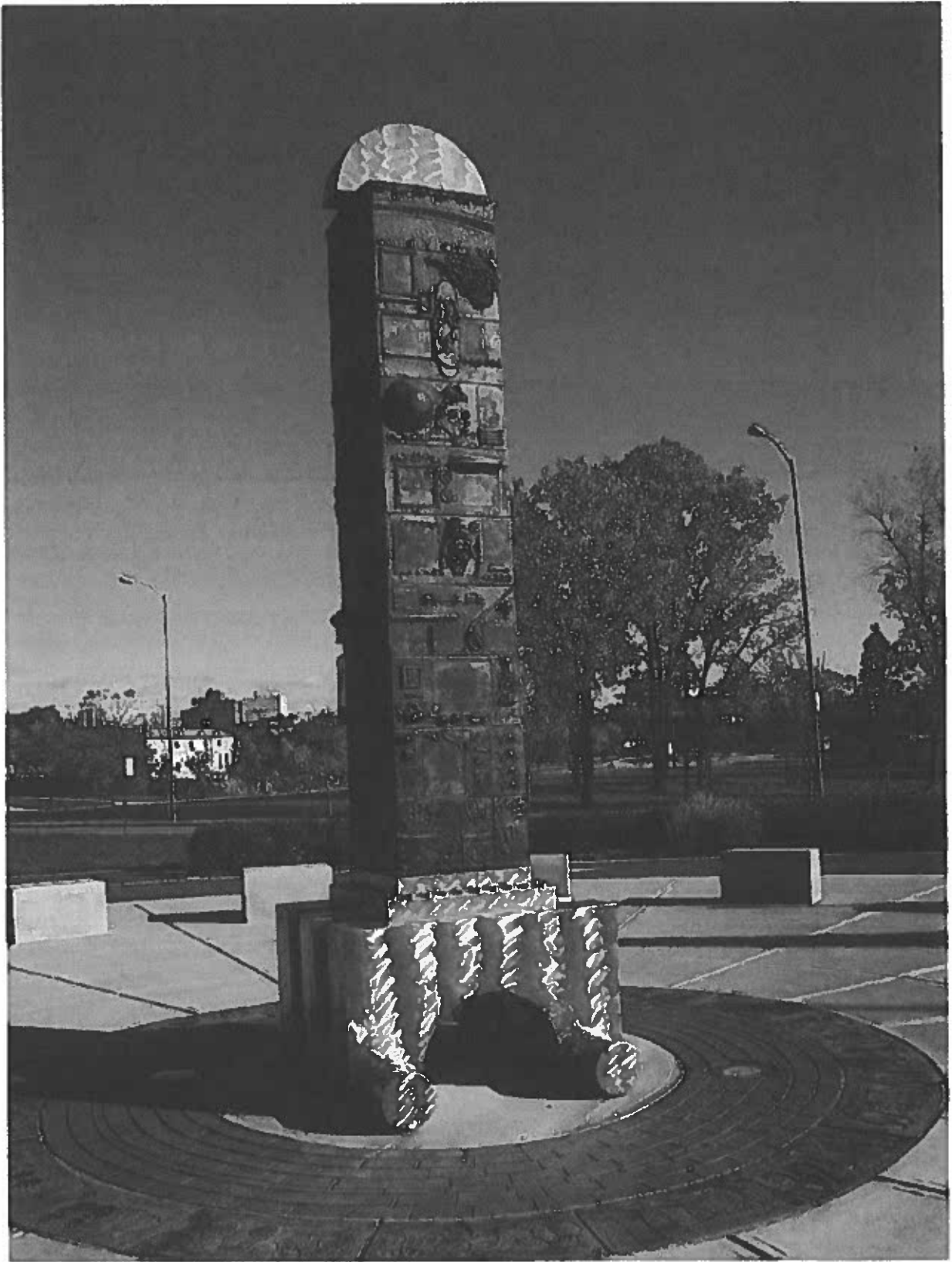






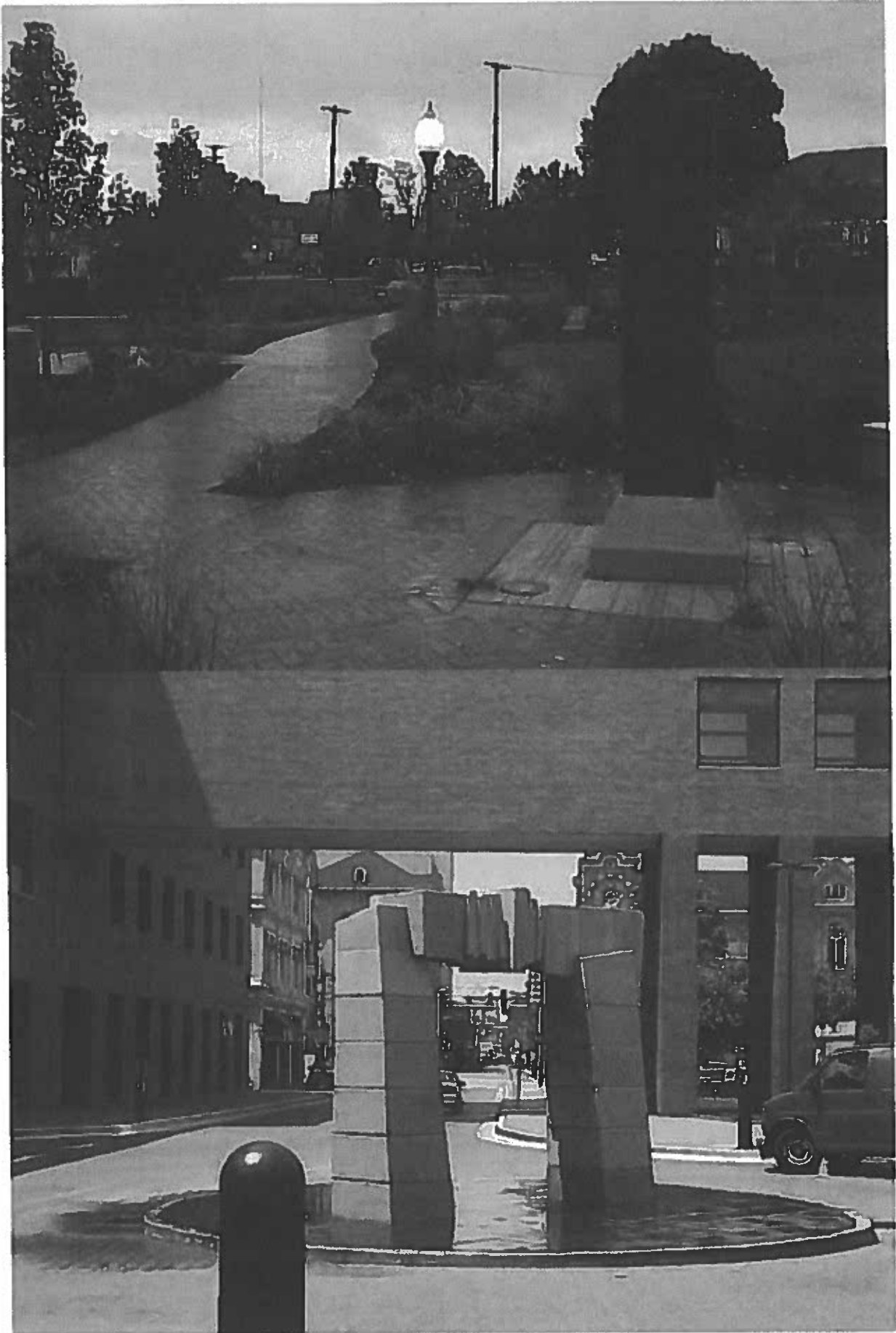








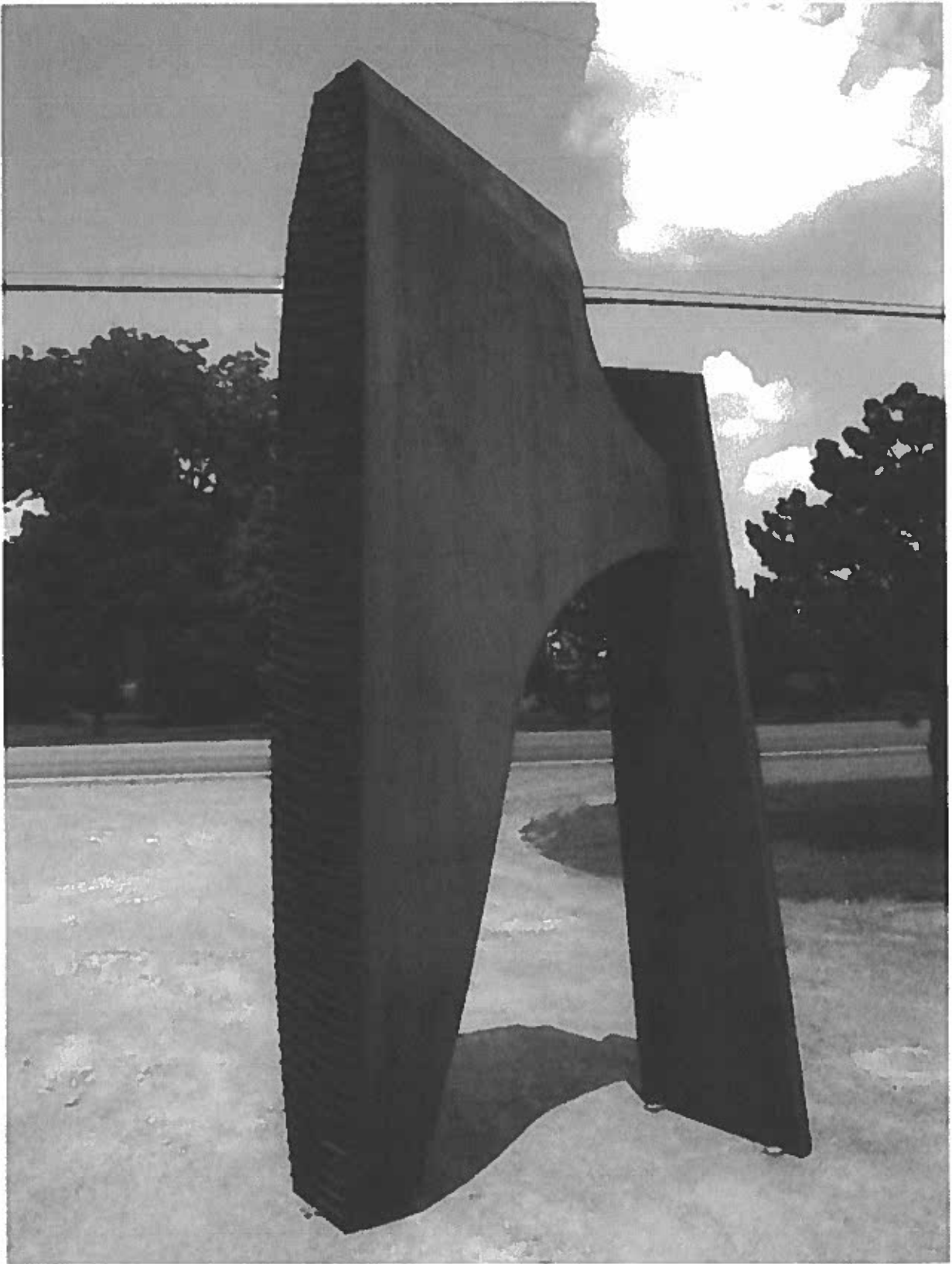


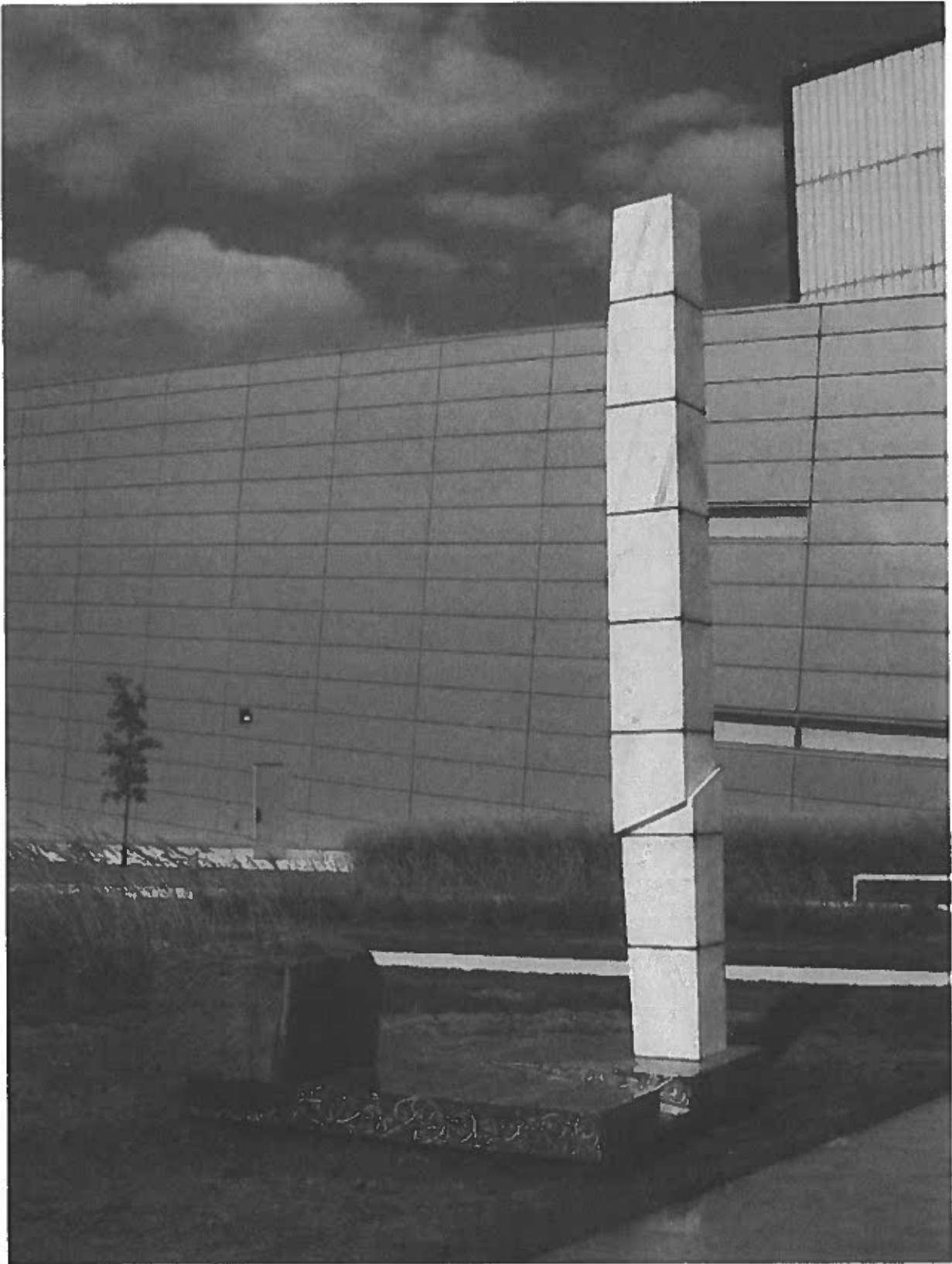


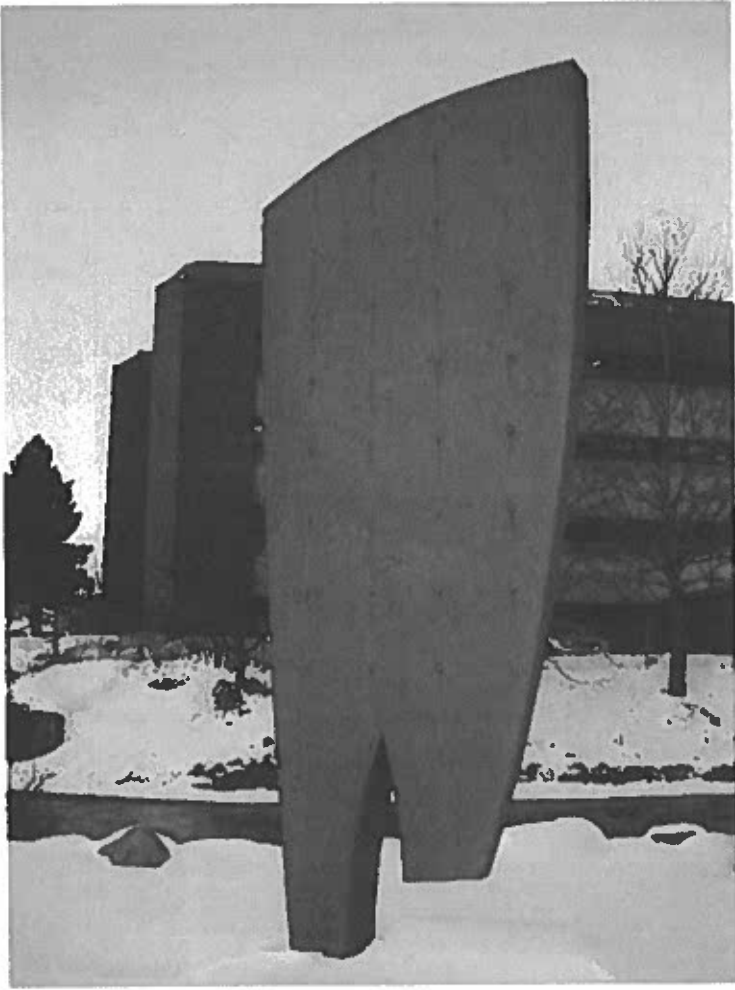




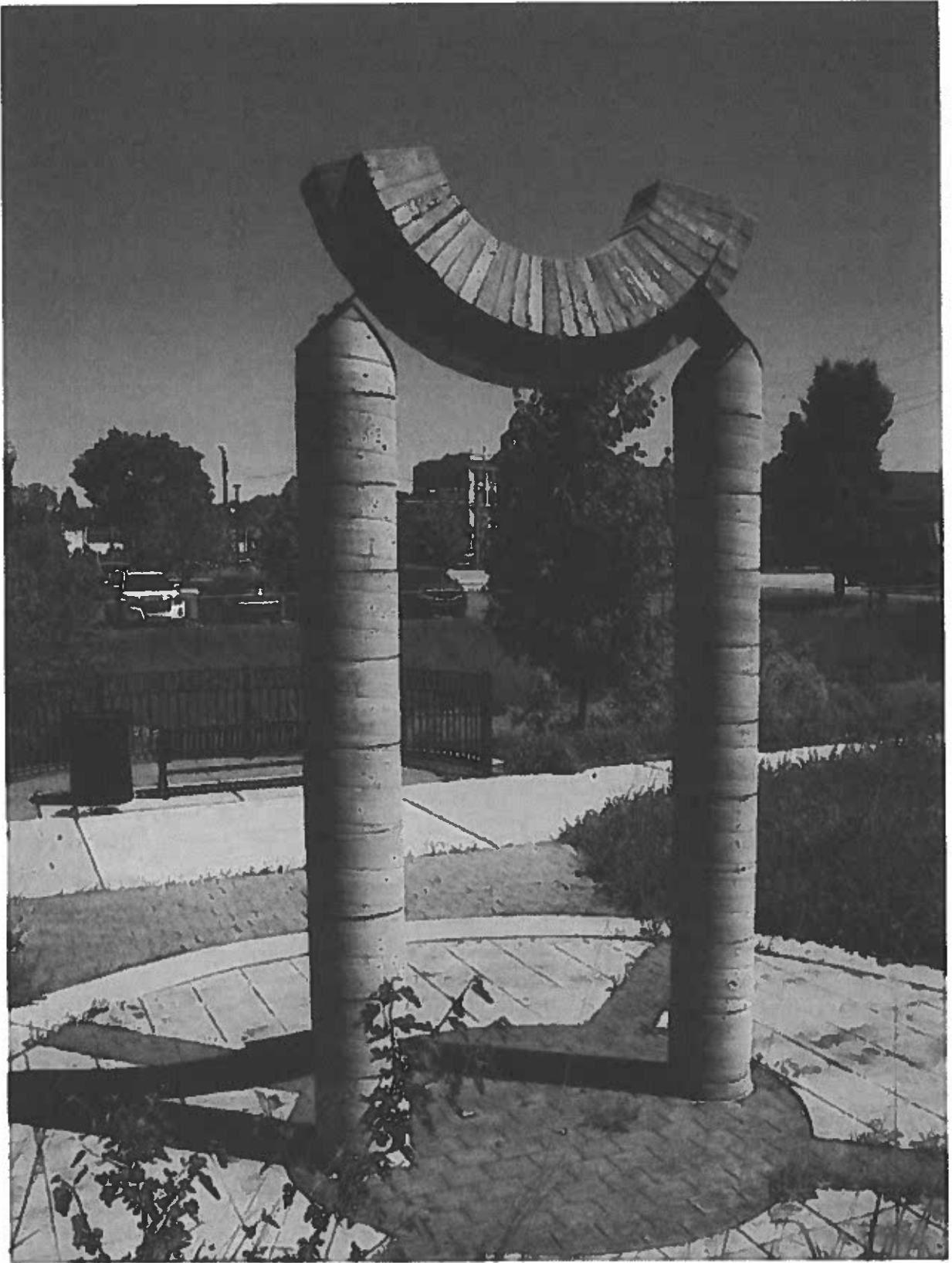




















## Artist Statement

### M L King Boulevard Arch (Look-up and dream!)

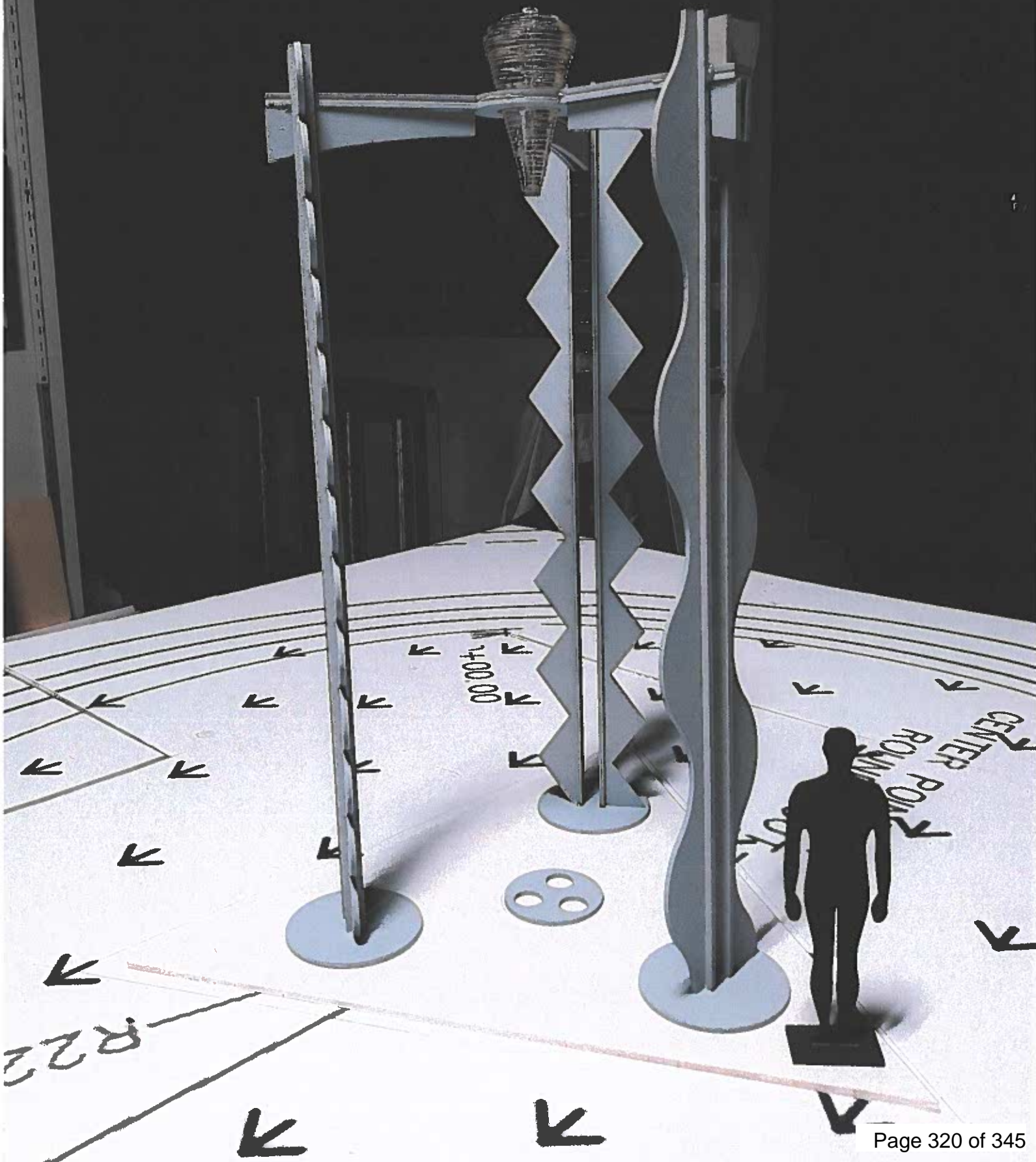
I have always had a fascination with architecture, in particular columns and arches. The arch is a powerful symbol that denotes an entry or new beginning, in this case to/for the South End of Jackson.

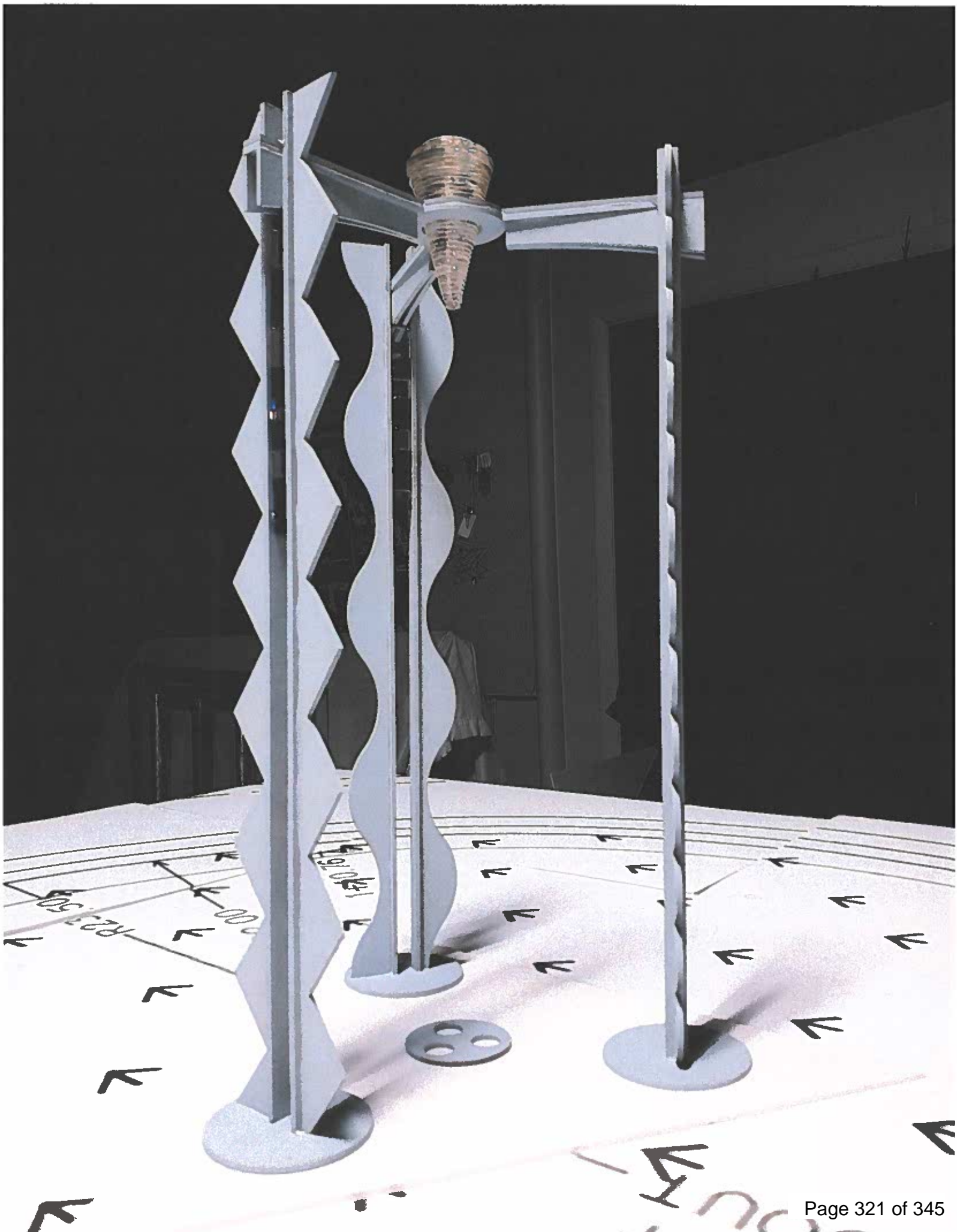
The three supporting columns and the glass patterns near the top derive their inspiration from details in the architecture of the surrounding neighborhoods. Each column is intentionally different to reflect the diversity within the community. At the top, the columns are 'unified' with the 'Y' shaped lintel that supports an illuminated 'orb' that represents our collective hope and dreams.

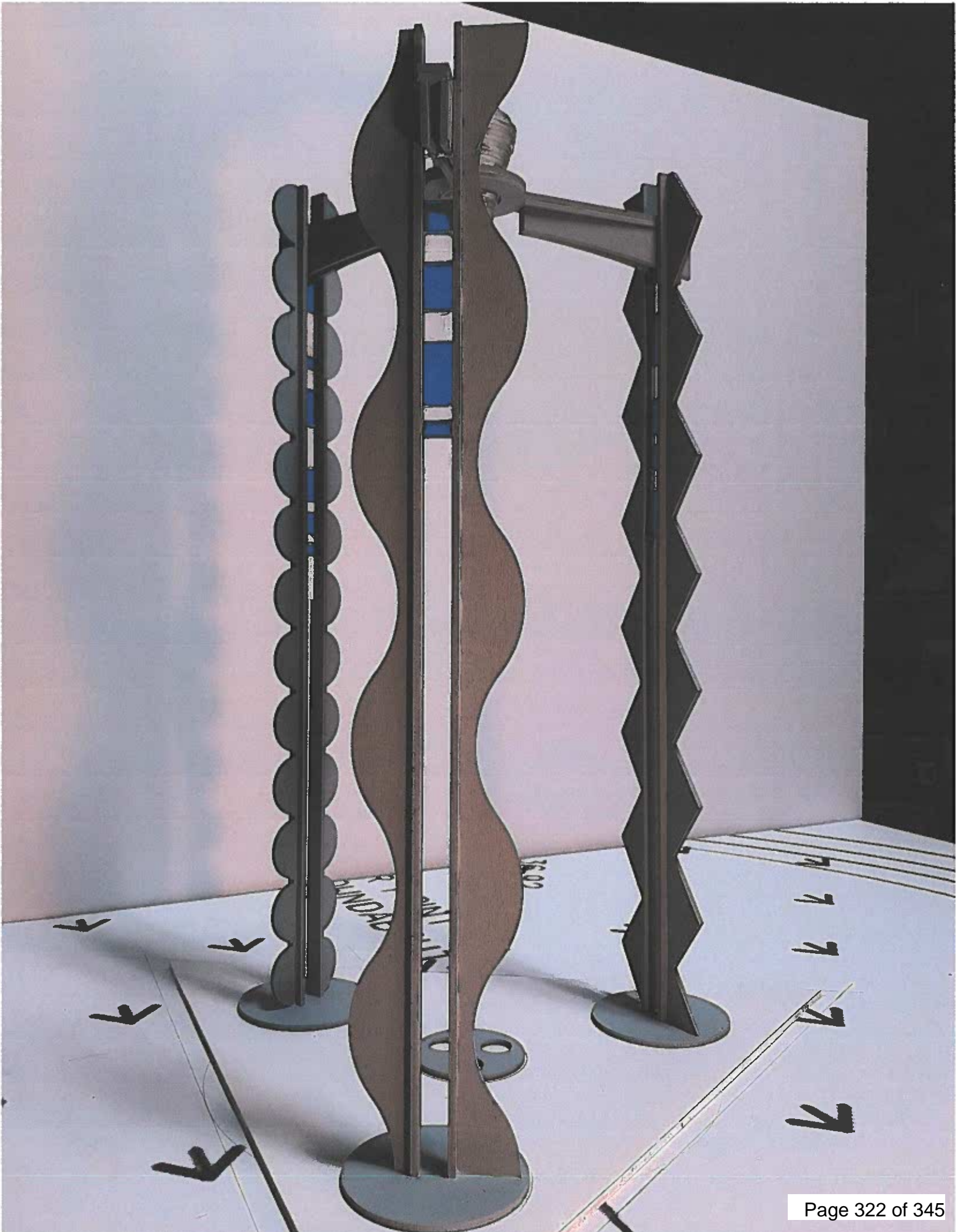
---

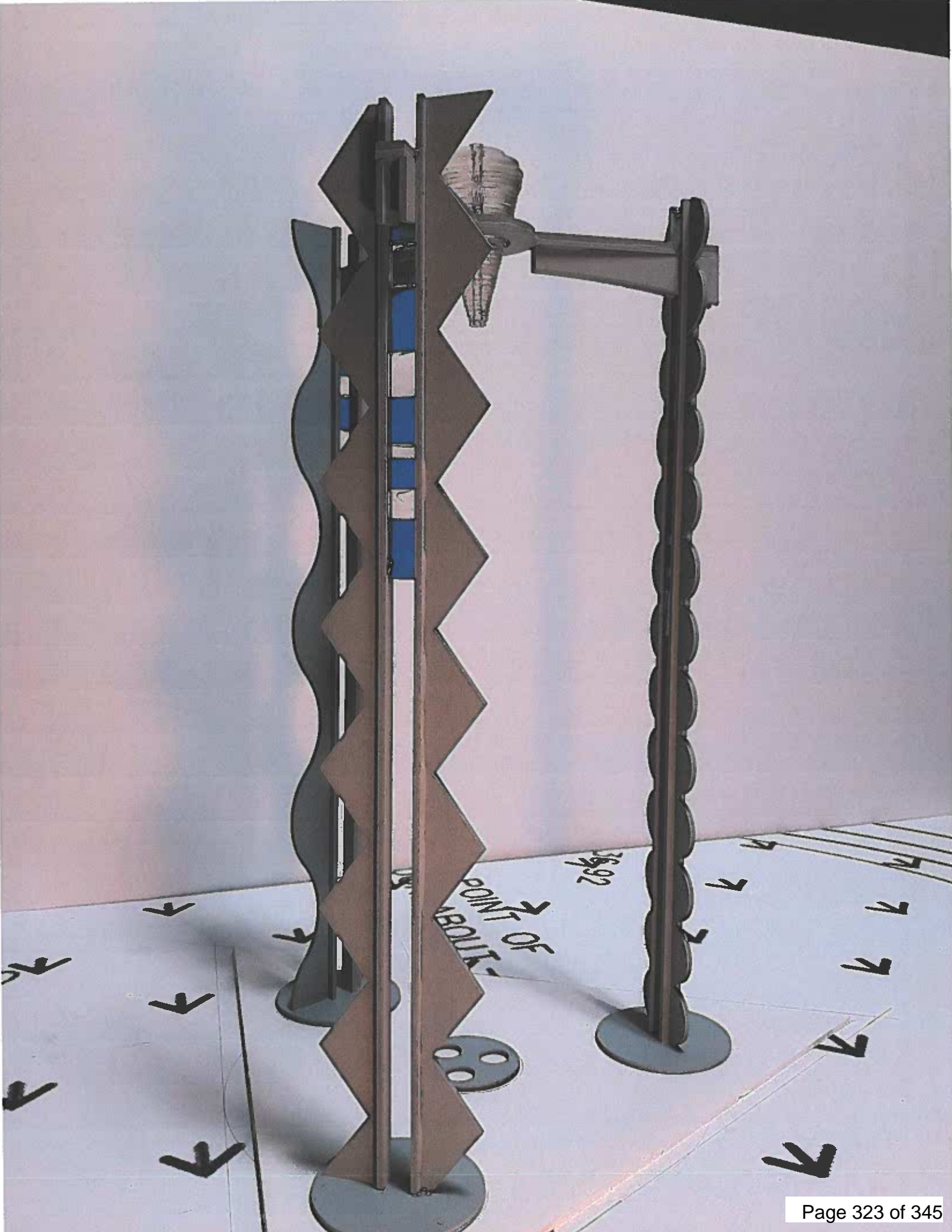
#### Facts about this proposal:

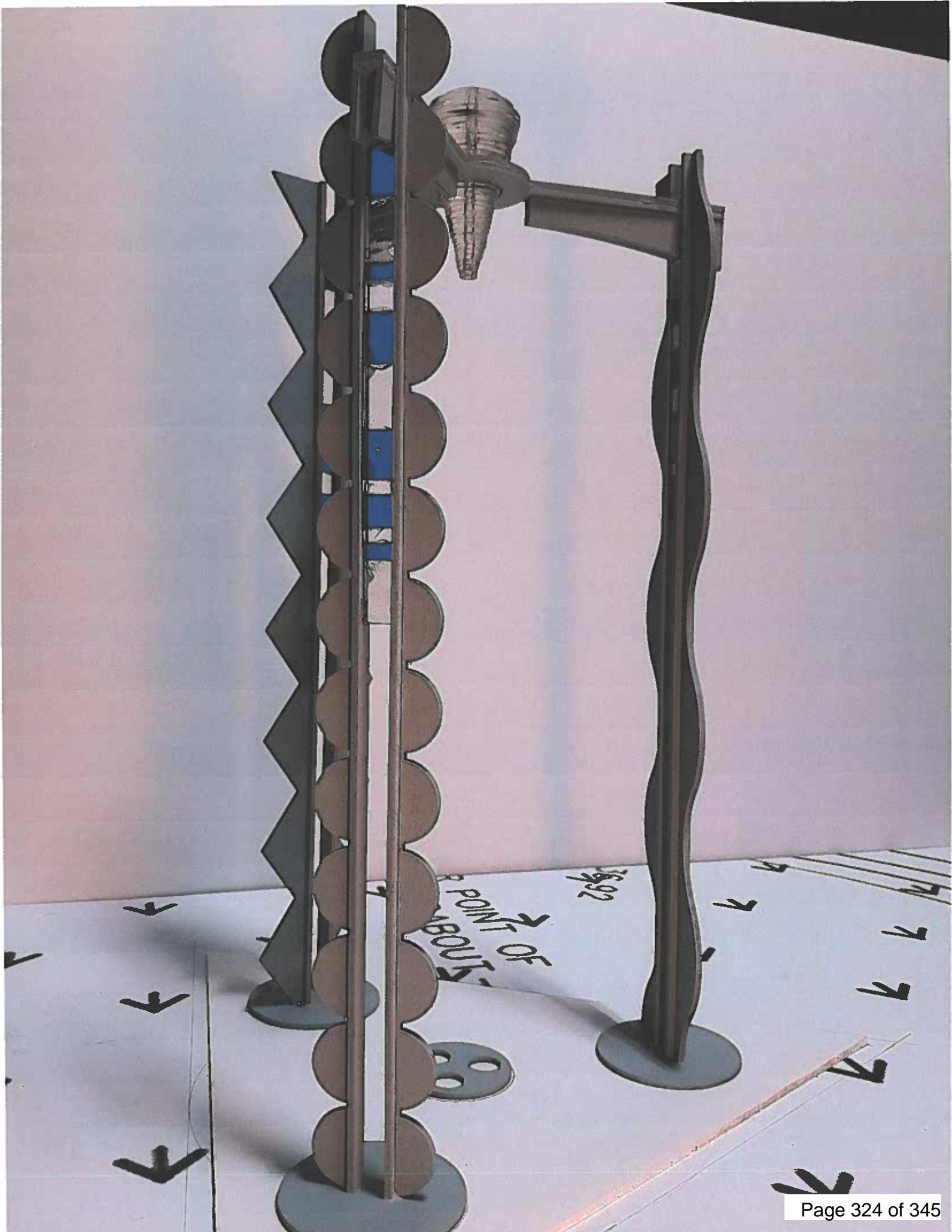
- The columns are 18'0 tall and made from W16-26# wide flange steel beams.
- The column inserts are ¾" x 6" cast glass panels of various lengths. They will vary in intensity with the available light.
- The 'orb' is fabricated from layers of laser-cut 1" SAR Acrylic sheet corrected for ultra-violet light. At night, the layers will refract the light and it will glow!
- The sculpture is light from the bottom at the center with three LED spot lights that most importantly illuminate the 'orb' and the other features become secondary.

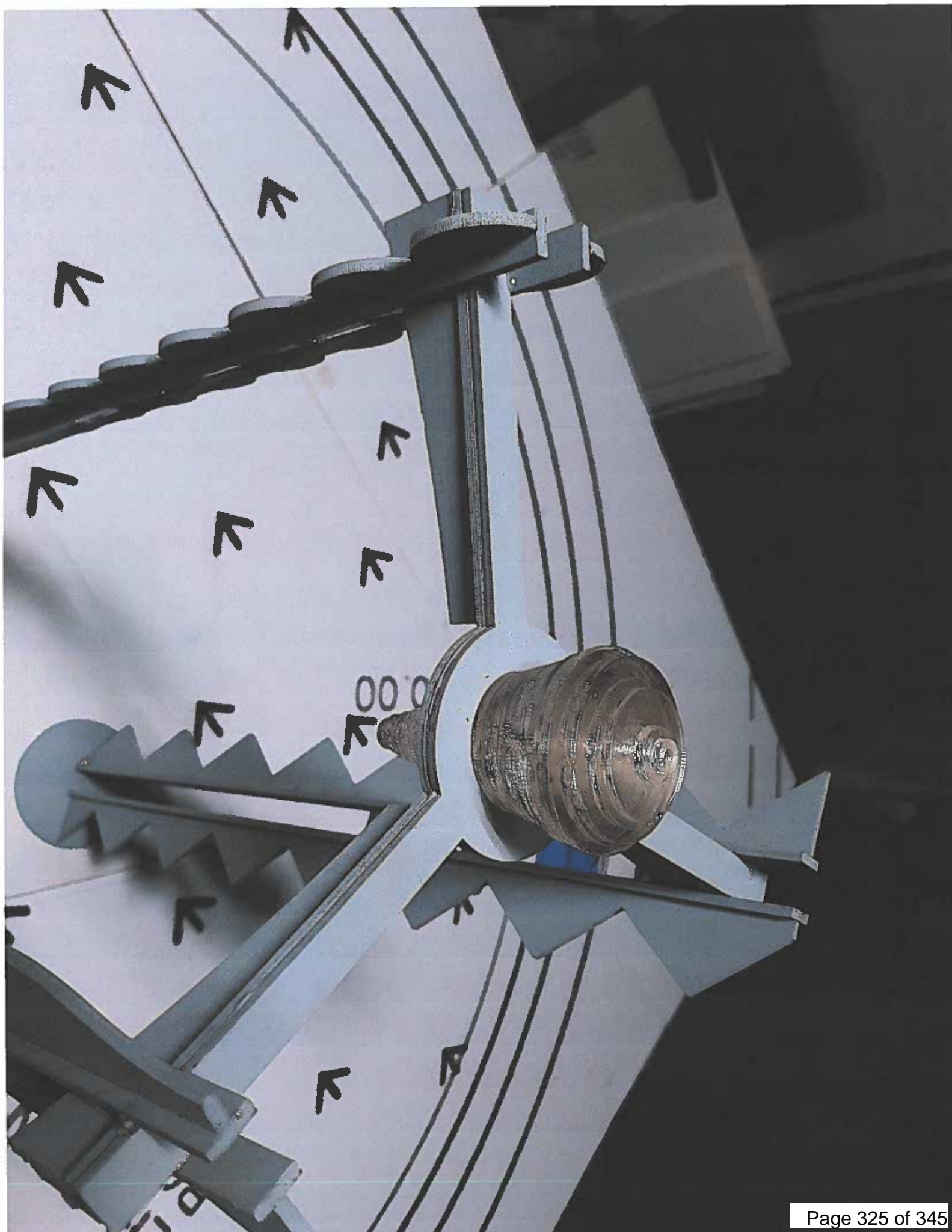


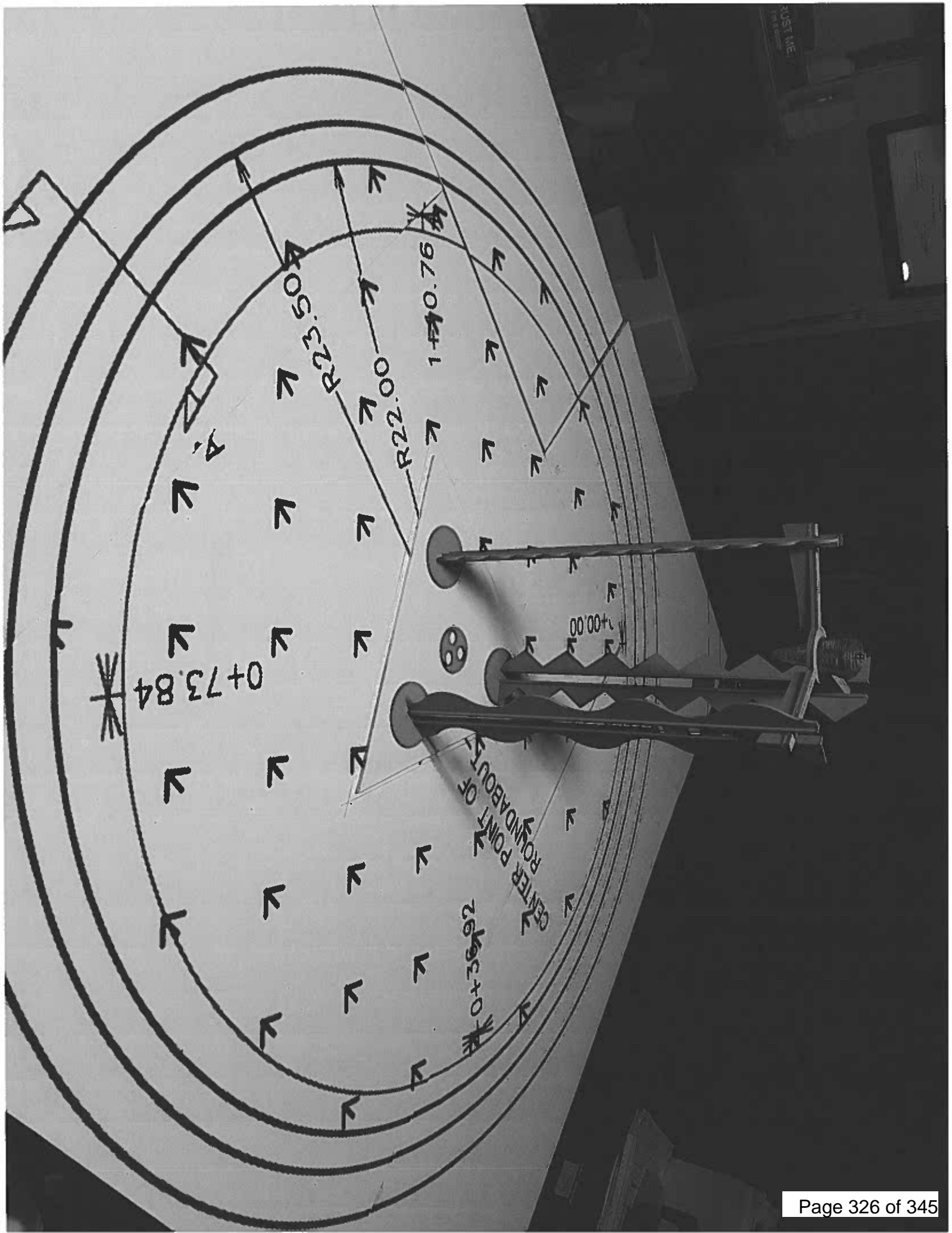












## Email Public Comment

## Kelli Hoover

---

**From:** Recreation  
**Sent:** Thursday, December 22, 2022 12:45 PM  
**To:** Kelli Hoover  
**Subject:** FW: MLK Roundabout Art

-----Original Message-----

**From:** Alexis Trolz <alexis.trolz@yahoo.com>  
**Sent:** Thursday, December 22, 2022 11:35 AM  
**To:** Recreation <recreation@cityofjackson.org>  
**Subject:** MLK Roundabout Art

Hi there!

Sending in my input on the sculpture to be installed at the MLK roundabout. My vote is for the MLK Boulevard arch. Reading the thought and intention behind this design really spoke to me. I think it would be a beautiful tribute to our community, and a constant reminder that it takes all of us coming together for common goals in order to be the change that we want to see.

-Alexis Trolz

## Kelli Hoover

---

**From:** Recreation  
**Sent:** Thursday, December 22, 2022 3:14 PM  
**To:** Kelli Hoover  
**Subject:** Fwd: MLK sculpture

Sent from my iPhone

Begin forwarded message:

**From:** Elizabeth Wray <ebwray@yahoo.com>  
**Date:** December 22, 2022 at 2:14:28 PM EST  
**To:** Recreation <recreation@cityofjackson.org>  
**Subject:** MLK sculpture

Thank you for asking for the public's input.  
I like Ken Thompson's idea. Very insightful with hope and dreams!

Sent from my iPhone

## Kelli Hoover

---

**From:** Recreation  
**Sent:** Thursday, December 22, 2022 8:39 PM  
**To:** Kelli Hoover  
**Subject:** Fwd: mlk round about art comment

Sent from my iPhone

Begin forwarded message:

**From:** Kristine Squiers <kristinesquiers936@msn.com>  
**Date:** December 22, 2022 at 7:53:23 PM EST  
**To:** Recreation <recreation@cityofjackson.org>  
**Subject:** mlk round about art comment

I think this one is the best. I like the glowing aspect.  
<https://www.cityofjackson.org/DocumentCenter/View/10903/Artist-Statement-from-Ken-Thompson>

Sent from Mail for Windows

Click [here](#) to report this email as spam.

## Kelli Hoover

---

**From:** Recreation  
**Sent:** Thursday, December 29, 2022 7:23 PM  
**To:** Kelli Hoover  
**Subject:** Fwd: Morrell St Roundabout Sculpture

Sent from my iPhone

Begin forwarded message:

**From:** Michelle Donnelly <allanswife2007@gmail.com>  
**Date:** December 29, 2022 at 6:54:04 PM EST  
**To:** Recreation <recreation@cityofjackson.org>  
**Subject:** **Morrell St Roundabout Sculpture**

*Good Evening,*

**My vote would go to :**  
"ML King Boulevard Arch" by Ken Thompson

--

**Michelle Donnelly**

Strive not to be a success, but rather to be of value. —Albert Einstein

Click [here](#) to report this email as spam.

## Open House Public Comment

**Martin Luther King Jr.  
Roundabout Sculpture  
Community Input Form**

Artist: \_\_\_\_\_

Piece: \_\_\_\_\_

Comments: \_\_\_\_\_

Plates in African  
American color  
would enhance  
the display

**Martin Luther King Jr.  
Roundabout Sculpture  
Community Input Form**

Artist: Ken Thompson

Piece: \_\_\_\_\_

Comments: would be  
a good choice

\_\_\_\_\_  
\_\_\_\_\_  
\_\_\_\_\_  
\_\_\_\_\_

**Other Public Submissions**  
**Not related to artist**

## Kelli Hoover

---

**From:** Recreation  
**Sent:** Wednesday, December 21, 2022 3:25 PM  
**To:** Kelli Hoover  
**Subject:** Fwd: MLK Sculpture

Sent from my iPhone

Begin forwarded message:

**From:** water@daenvironmental.com  
**Date:** December 21, 2022 at 3:21:49 PM EST  
**To:** Recreation <recreation@cityofjackson.org>  
**Subject:** MLK Sculpture

As someone who has had 3 near misses with folks who don't bother to stop nor look before entering the MLK roundabout, adding a sculpture which blocks visibility is a terrible idea. Add the sculpture to one of the corners if you must but please don't obstruct the roundabout. None of the roundabouts in Ann Arbor and other cities have something in the center blocking the view of oncoming traffic. Only in Jackson is this a problem. If you add a sculpture to MLK, it will just be another intersection I will avoid.

Deb

Click [here](#) to report this email as spam.

## Kelli Hoover

---

**From:** Recreation  
**Sent:** Thursday, December 22, 2022 8:42 AM  
**To:** Kelli Hoover  
**Subject:** Fwd: Roundabout sculpture

Sent from my iPhone

Begin forwarded message:

**From:** Darlene Weaver <darlinwifey@gmail.com>  
**Date:** December 22, 2022 at 8:32:05 AM EST  
**To:** Recreation <recreation@cityofjackson.org>  
**Subject: Roundabout sculpture**

I vote no on a sculpture in the roundabout - it would be an added distraction, reduce visibility and create potential for more vandalism. Please put the funds towards things to improve safety such as street & sidewalk repairs & street lighting.

Darlene Weaver

## Kelli Hoover

---

**From:** Recreation  
**Sent:** Thursday, December 22, 2022 12:45 PM  
**To:** Kelli Hoover  
**Subject:** FW: MLK Drive Roundabout

-----Original Message-----

**From:** Shawn Allgood <smallgood@outlook.com>  
**Sent:** Thursday, December 22, 2022 12:27 PM  
**To:** Recreation <recreation@cityofjackson.org>  
**Subject:** MLK Drive Roundabout

Good afternoon,

I am writing to you today because I feel compelled to provide my opinion on this initiative. I know that I'm not alone, but this project seems wasteful and self-serving. The kind of money that is being poured into something like this would be better served elsewhere. Beyond my budget concerns on this endeavor, it seems like mismanagement of space to put yet another sculpture in or around the downtown area. Sculptures, while providing cultural gravity to a neighborhood serve no other purpose beyond an inflated sense of what art is supposed to mean to the community. In my opinion, a better use of the space would be an arrangement of perennial flora with a propensity to attract pollinators. Serving double duty here by providing a microhabitat for wildlife and also lifting the area beyond the concrete jungle it currently appears to be. My sincere hope is that you reconsider, avoid installing another sculpture, and repurpose the funds to be spent on this project on ventures more appropriate for the community's needs.

V/r  
Shawn Allgood

## Kelli Hoover

---

**From:** Recreation  
**Sent:** Thursday, December 22, 2022 12:47 PM  
**To:** Kelli Hoover  
**Subject:** FW: Sculptures

-----Original Message-----

**From:** Yeaman, Jan <Jan.Yeaman@arbor.edu>  
**Sent:** Wednesday, December 21, 2022 8:41 PM  
**To:** Recreation <recreation@cityofjackson.org>  
**Subject:** Sculptures

I'm wondering, with Jackson's rich history, if there couldn't be a design that isn't abstract modern—something that would be more reflective of Jackson or contributors to Jackson. Maybe something reflecting Jackson's great contributions with the Underground Railroad?

Jan Yeaman

Sent from my iPhone

## Kelli Hoover

---

**From:** Recreation  
**Sent:** Thursday, December 22, 2022 12:48 PM  
**To:** Kelli Hoover  
**Subject:** FW: Statue at Morrel and MLK

-----Original Message-----

**From:** Mark Zande <mzande@hotmail.com>  
**Sent:** Wednesday, December 21, 2022 5:10 PM  
**To:** Recreation <recreation@cityofjackson.org>  
**Subject:** Statue at Morrel and MLK

I think a sculpture of Martin Luther King would be most appropriate. Merry Christmas! Mark L Zande

Sent from my iPhone

## Kelli Hoover

---

**From:** Recreation  
**Sent:** Thursday, December 22, 2022 4:16 PM  
**To:** Kelli Hoover  
**Subject:** Fwd:

Sent from my iPhone

Begin forwarded message:

**From:** Angel Colligan <bin.baal@gmail.com>  
**Date:** December 22, 2022 at 4:08:59 PM EST  
**To:** Recreation <recreation@cityofjackson.org>

Use our tax money for literally anything else, please. Sculptures are not it when we have residents freezing and dying in the streets.

Sincerely,  
Angela Colligan  
728 N State St  
Jackson, Mi

Click [here](#) to report this email as spam.

## Kelli Hoover

---

**From:** Recreation  
**Sent:** Friday, December 23, 2022 5:57 AM  
**To:** Kelli Hoover  
**Subject:** Fwd:

Sent from my iPhone

Begin forwarded message:

**From:** Jean Carpenter <jeancarpenter68@gmail.com>  
**Date:** December 23, 2022 at 5:53:14 AM EST  
**To:** Recreation <recreation@cityofjackson.org>

Why not do one of Martin Luther king.

Click [here](#) to report this email as spam.

## Kelli Hoover

---

**From:** Recreation  
**Sent:** Wednesday, December 28, 2022 10:17 PM  
**To:** Kelli Hoover  
**Subject:** Fwd: MLK sculpture

Sent from my iPhone

Begin forwarded message:

**From:** Stephanie Riley <sriley63@gmail.com>  
**Date:** December 28, 2022 at 9:39:13 PM EST  
**To:** Recreation <recreation@cityofjackson.org>  
**Subject:** **MLK sculpture**

I don't find any the the submitted sculptures inspiring. Are these the only ones? What about a living landscape sculpture/garden? Who doesn't love God's beauty?

Click [here](#) to report this email as spam.

## Kelli Hoover

---

**From:** Recreation  
**Sent:** Sunday, January 1, 2023 4:26 PM  
**To:** Kelli Hoover  
**Subject:** Fwd: Sculptures for Milk

Sent from my iPhone

Begin forwarded message:

**From:** Kandice Cook <kcook0903@gmail.com>  
**Date:** January 1, 2023 at 2:41:30 PM EST  
**To:** Recreation <recreation@cityofjackson.org>  
**Subject:** Sculptures for Milk

All of the designs are ugly, not to mention will be awful to try and see around while driving. Why do we need to waste more money on "art" that will likely get shot or driven through in the next few years? Just put some fruit trees or shrubs and flowers back in for the bees and butterflies. They're cheaper to replace should an accident happen. Maybe even add a bench for those who mostly walk to their destinations. Our ecosystem needs plant life and places for people to enjoy nature, not more statues. If you want to honor some great people from our city, do more murals or dedicate to the homeless shelters in their names. Something that makes a difference, not just takes up space. Sure, decorations are cute, but what good will come from them? Invest in the future of the city and it's people.

Click [here](#) to report this email as spam.

## Kelli Hoover

---

**From:** Recreation  
**Sent:** Sunday, January 1, 2023 4:27 PM  
**To:** Kelli Hoover  
**Subject:** Fwd: Sculpture feedback.

Sent from my iPhone

Begin forwarded message:

**From:** Karrie Williams <nykarriew@yahoo.com>  
**Date:** December 28, 2022 at 5:49:30 PM EST  
**To:** Recreation <recreation@cityofjackson.org>  
**Subject:** **Sculpture feedback.**

Good evening city of Jackson I've taken a look at the sculptures that may be placed on the roundabout. Honestly... I'm not feeling any of the options why does there need to be a statue there? It seems like a lightning conduction site to me! Can we get a beautiful flower bed instead and just scrap all those?

Sent from K.Annette

## Kelli Hoover

---

**From:** Recreation  
**Sent:** Sunday, January 1, 2023 4:27 PM  
**To:** Kelli Hoover  
**Subject:** Fwd: Roundabout sculptures

Sent from my iPhone

Begin forwarded message:

**From:** Linda Bardel <lindabardel@gmail.com>  
**Date:** December 27, 2022 at 11:23:27 AM EST  
**To:** Recreation <recreation@cityofjackson.org>  
**Subject:** Roundabout sculptures

I love the Sandhill cranes sculpture in the roundabout over by the parks. But I've wondered if it takes attention away from safe driving? Has that been studied? Would a low flower bed or low fountain/rock wall be less distracting? Just a thought...