



AGENDA- CITY COUNCIL MEETING

Tuesday, February 7, 2023
6:30 PM

Page

1. CALL TO ORDER.

2. PLEDGE OF ALLEGIANCE.

Invocation will be given by 6th Ward Councilmember Will Forgrave.

3. ROLL CALL.

4. ADOPTION OF AGENDA.

5. PRESENTATIONS/PROCLAMATIONS.

- 5.1 A Proclamation declaring the week of February 1, 2023 to February 7, 2023 as Gun Violence Survivors Week.

5

[Gun Violence Survivors Week.pdf](#) 

6. PUBLIC HEARINGS.

- 6.1 Hearing of Necessity - Pavement Replacement on North Street, Wisner Street to West Avenue
1. Resolution ordering the construction and preparation of the special assessment roll

6 - 14

[Necessity - Pavement Replacement on North Street from Wisner to West Ave.pdf](#) 

7. CITIZEN COMMENTS.

(3-Minute Limit)

8. PETITIONS & COMMUNICATION FROM CITY STAFF AND OTHER GOVERNMENTAL ENTITIES.

(Accept and Place on File)

- 8.1 City of Jackson, Michigan Financial Statements 15 - 22
As of and For the Six Months Ended December 31, 2022.
[Monthly Financial Statements 2022-12-31.pdf](#) 

9. CONSENT CALENDAR

Consent Action

- 9.1. Minutes of the Regular Meeting of January 24, 2023 23 - 32
Approve the minutes of the regular City Council Meeting of January 24, 2023.
[CITY COUNCIL - Jan 24 2023 - Minutes - Pdf](#) 
- 9.2. Accept with regret, the resignation of Bart Hawley from the 33
Downtown Development Authority Board
[DDA - Bart Hawley Resignation.pdf](#) 
- 9.3. Accept with regret, the resignation of Diane Cerqueira from 34
the Local Officers Compensation Committee
[LOCC-DCerqueira Resignation.pdf](#) 

10. OTHER BUSINESS.

- 10.1. City Homeless Efforts - Winter Sheltering of the Unhoused 35 - 41
[RIA 1-27-23 report 2.pdf](#) 

11. NEW BUSINESS.

- 11.1 Award the contract to Michigan Agribusiness Solutions LLC of 42 - 125
Saginaw, Michigan, for the hauling and land applicaiton of
biosolids from the Wastewater Treatment Plant [Biosolids
Removal - WWTP.pdf](#) 
*Award the contract to Michigan Agribusiness Solutions LLC of Saginaw,
Michigan for the hauling and land application of biosolids removal at a
price of \$0.041 per gallon.*
- 11.2 Jackson Wastewater Treatment Plant Main Switchgear 126 - 129
Project Change Order #1
[Change Order #1 - WWTP Main Switchgear.pdf](#) 
*Approve Project Change Order #1, for the Jackson Wastewater
Treatment Plant Main Switchgear Project to allow Expo Technologies*

LLC to perform the unforeseen but necessary wire replacement in the amount of \$16,839.00.

- 11.3 Changes to the Standard Lighting Contract for streetlights with Consumers Energy for the removal of one streetlight. 130 - 136
[Engineering Consumers Streetlight Contr Change.pdf](#) 
Approve the resolution for Changes to the Standard Lighting Contract for one streetlight removal with Consumers Energy and authorize the Mayor and City Clerk to execute the appropriate documents.
- 11.4 Revoke Conditional Phase One Facility License for a Medical/Adult Use Marihuana Establishment 137 - 138
[JARS Revoke Phase 1 conditional Marihuana License Packet.pdf](#) 
Revoke conditional phase one facility license for JARS Holding LLC Medical/Adult Use Marihuana Provisioning Center at 156 Cooper.
- 11.5 Approve Conditional Phase One Facility License for a Medical/Adult Use Marihuana Establishment as per Ordinance Section 16-516 139 - 140
[Legends Green Venture LLC Class C Phase 1 Contitional License.pdf](#) 
Approve a conditional Phase One facility licenses for Legend Green Venture LLC. One medical and one adult use Marihuana Class C Grower at 712 E. South Street, per Ordinance Section 16-516. Authorize the City Attorney to prepare the Development Agreement and Authorize the City Manager to sign the Development Agreement.
- 11.6. Approval of 'Community of Shapes' Art Sculpture at the MLK Equality Trail near the intersection of MLK Drive and High Street 141 - 167
[Community of Shapes Sculpture.pdf](#) 
Approval of Doug Jones and Chris Turner's 'Community of Shapes' Art Sculpture at the MLK Equality Trail near the intersection of MLK Drive and High Street and for the City Attorney and the Parks and Recreation Director to move forward with the artist agreement including delivery, installation and not to exceed \$30,000 contract.
- 11.7 No Mow May Resolution 168 - 171
[No Mow May.pdf](#) 
A recommendation to disapprove the resolution for “No Mow May” in the City of Jackson.

- 11.8 Approve the sale of City owned property located at 352 N. Grinnell Street, 823 Maltby Street, 612 E. Ganson Street and 704 E. Ganson Street to Fresh Start Real Estate Services, LLC
[Fresh Start Property Sale.pdf](#) 

Approve the sale of City owned property for \$300 per lot, located at 352 N. Grinnell Street, 823 Maltby Street, 612 E. Ganson Street, and 704 E. Ganson Street to Fresh Start Real Estate Services, LLC for the purpose of building four new, single family homes. Authorize the City Attorney to create the Property Transfer Agreement and any other authorized documents to complete the sale of the property; authorize the City Manager to sign Property Transfer and other related documents.

12. CLOSED SESSION

- 12.1 Conduct closed session pursuant to MCL 15.228(d) in order to consider the purchase or lease of real property up to the time an option to purchase or lease that real property is obtained.
- 12.2 Conduct closed session pursuant to MCL 15.228(d) in order to consult with legal counsel regarding specific pending litigation.

13. CITY COUNCILMEMBER'S COMMENTS.

14. MANAGER'S COMMENTS.

15. ADJOURNMENT.

**GUN VIOLENCE SURVIVORS WEEK PROCLAMATION
DECLARING THE WEEK OF FEBRUARY 1, 2023 TO FEBRUARY 7, 2023 TO MARK NATIONAL GUN VIOLENCE
SURVIVOR WEEK**

This proclamation declares the week of February 1, 2023, to February 7, 2023, to be National Gun Violence Survivor Week in the City of Jackson, Michigan to honor and remember all victims and survivors of gun violence and uplift the resilient voices of survivors across the nation.

WHEREAS, every year, nearly 40,000 Americans are killed in acts of gun violence and approximately 76,000 more are shot and wounded;

WHEREAS, every year, on average, 1,212 Michigan are killed in acts of gun violence and nearly 3,507 more are shot and wounded;

WHEREAS, by early February, more Americans are killed with guns than are killed in our peer countries in an entire calendar year;

WHEREAS, a gun violence survivor is anyone who has personally experienced gun violence — whether you have witnessed an act of gun violence, been threatened or wounded with a gun, or had someone you know and cared for wounded or killed;

WHEREAS, forms of gun violence can include, but are not limited to: gun suicides, gun homicides, domestic violence involving a gun, shootings by law enforcement, and unintentional shootings;

WHEREAS, 59 percent of American adults, including 71 percent of Black and Latinx Americans, or someone they care for has experienced gun violence in their lifetime, demonstrating the reach and impact gun violence has in communities across America;

WHEREAS, firearms are the leading cause of death for children and teens;

WHEREAS, people in America in cities across the nation are working to end the senseless violence by advocating for commonsense gun safety legislation;

WHEREAS, by commemorating National Gun Violence Survivors Week on February 1 to February 7, cities across America will raise awareness about gun violence and honor the lives stolen by gun violence; and

WHEREAS, we renew our commitment to reduce gun violence and pledge to do all we can to keep firearms out of the hands of those who are a danger to themselves or others and encourage responsible gun ownership to help keep our communities safe.

NOW, THEREFORE BE IT RESOLVED, that the City of Jackson declares February 1 to February 7, 2023 to be National Gun Violence Survivors Week. We encourage all citizens to support their communities' efforts to prevent the tragic effects of gun violence and to honor and value human lives.

IN WITNESS WHEREOF, on this date, February 7, 2023, I have hereunto set my hand and caused the official seal of the City of Jackson, Michigan to be affixed.



Daniel Mahoney, Mayor of the City of Jackson, Michigan

MEMO TO: Honorable Mayor and City Councilmembers
FROM: Andrea Muray, City Clerk
DATE: February 7, 2023
SUBJECT: Public Hearing and Resolution determining the necessity for pavement replacement on North Street from Wisner Street to West Avenue.

RECOMMENDATION:

Public hearing of necessity for pavement replacement on North Street from Wisner Street to West Avenue
Resolution ordering the construction and preparation of the special assessment roll.

A public hearing was established at the City Council's January 10, 2022 meeting for February 7, 2022. The required notice was published in the Jackson Citizen Patriot and a notification letter was sent to each property owner.

Your consideration and concurrence is appreciated.

C: Jonathan Greene, City Manager

RESOLUTION
PAVEMENT REPLACEMENT

BY THE CITY COUNCIL:

WHEREAS, under the authority granted by Ordinance No. 22-8 and 22-12, the City Council has reviewed the report regarding the necessity of pavement replacement on North Street from Wisner Street to West Avenue the following estimated costs, to wit:

Street Construction Assessments	\$ 302,327
<u>MDOT/FHWA Funds</u>	<u>\$ 300,000</u>
Total Project Cost	\$ 622,327

WHEREAS, notice has been duly given that the City Council would hold a public hearing in the City of Jackson on Tuesday, the 7th day of February, 2023 at 6:30 p.m. to hear any and all objections and suggestions by interested parties to said public improvement; and

WHEREAS, the City Council and Assessor having heard all suggestions and objections made thereto and having fully considered the same;

NOW, THEREFORE, BE IT RESOLVED that the City Council hereby determines that the street construction is a necessary public improvement and directs staff to proceed with the street construction, in accordance with plans, maps, and specifications in the City Engineer's office; and

BE IT FURTHER RESOLVED that the City Assessor is ordered to assess the cost of said improvement to the property owners who benefit therefrom on a front footage basis and prepare an assessment roll covering this assessment district as soon as possible after the public improvement has been completed.

* * * * *

State of Michigan)
County of Jackson) ss
City of Jackson)

I, Andrea Muray., City Clerk in and for the City of Jackson, County and State aforesaid, do hereby certify that the foregoing is a true and complete copy of a resolution adopted by the Jackson City Council on the 7th day of February, 2023.

IN WITNESS WHEREOF, I have hereunto affixed my signature and the seal of the City of Jackson, Michigan, on this 8th day of February, 2023.

Andrea Muray, City Clerk

MEMO TO: Mayor and City Councilmembers
FROM: Jonathan Greene, City Manager
DATE: January 10, 2023
SUBJECT: **Engineer's Report for Pavement Replacement
North Street – Wisner Street to West Avenue**

RECOMMENDATION:

Receive the Engineer's Report for pavement replacement on North Street from Wisner Street to West Avenue and establish February 7, 2023 at the City Council meeting as the time and place to hold a public hearing of necessity.

Attached is a report from Jon Dowling, City Engineer regarding a pavement replacement project on North Street.

I recommend approval for receipt and establishment of the public hearing of necessity. Your consideration and concurrence is appreciated.

JG

DEPARTMENTAL REPORT

MEMO TO: Jonathan Greene, City Manager
FROM: Jon H. Dowling, P.E., City Engineer
DATE: January 10, 2023

RECOMMENDATION: Receive the Engineer's Report for pavement replacement on North Street from Wisner Street to West Avenue and establish February 7, 2023 at the City Council meeting as the time and place to hold a public hearing of necessity.

SUMMARY

Engineering requests that City Council establish a public hearing of necessity to be held February 7, 2023 for pavement replacement on North Street from Wisner Street to West Avenue. This report is prepared for City Council per the Assessment Policy regarding the necessity of street reconstruction.

BUDGETARY CONSIDERATIONS

Estimated project costs and funding are as follows:

Street Construction Assessments	\$302,327
MDOT/FHWA Funds	<u>\$320,000</u>
Total Project Cost	\$622,327

If, upon the conclusion of the Public Hearing of Necessity, City Council orders the project to proceed, Engineering will proceed with letting the project and obtaining competitive bids to determine the true cost of the project. A special assessment roll will then be prepared by the City Assessor to establish individual parcel assessments.

HISTORY, BACKGROUND and DISCUSSION

Engineering records show that North Street was originally constructed from Center Street to West Avenue in 1963, and from Wisner Street to Center in 1966. The whole segment from Wisner to West was sealcoated in 1993, crack sealed in 1996, and crack sealed with sealcoating in 2006. The roadway has cracking, utility patches and potholes. The current PASER rating is 4. The attached photos show the current street conditions.

DISCUSSION OF THE ISSUE

Engineering proposes to remove the existing pavement and replace the pavement structure with new hot mix asphalt. Sidewalk ramps will be upgraded to comply with current Americans with Disabilities Act (ADA) requirements. New sidewalk to be installed on the south side of North Street from the Eaton Street right-of-way to Hibbard Avenue. Also proposing pavement replacement in the intersection of Wisner and North going approximately 140 feet north of North Street and approximately 80 feet south of North.

POSITIONS

I request receipt of the Engineer's Report for North Street pavement replacement from Wisner Street to West Avenue and approval of the establishment of February 7, 2023 at the City Council meeting as the time and place to hold a public hearing of necessity.



Photo 1: North St looking east toward West Ave



Photo 2: North St looking west toward Center St



Photo 3: North St looking east from Hibbard St



Photo 4: North St looking west from Hibbard St at north curb line



Photo 5: North St looking west from Hibbard St at south curb line



Photo 6: North St looking east from bank drive



Photo 7: North St looking west from bank drive



Photo 8: North St and Wisner St intersection looking northeast



Photo 9: Wisner St looking south from North St



Photo 10: Beaten path on south side of North St from Hibbard to existing sidewalk



City of Jackson, Michigan Financial Statements

As of and For the Six Months Ended December 31, 2022

Preliminary/Unaudited

INDEX:	Page
General Fund Expenditure Summary	1-2
All Other Funds - Expenditure Summary	3-4
All Funds - Revenue Summary	5-6
Notes to Revenue & Expenditure Summaries	7

City of Jackson, Michigan
General Fund Expenditure Summary
As of and For the Six Months Ended December 31, 2022
(Prepared on the Adopted Budget-Basis)
Preliminary/Unaudited

Function Department	2022/23 Budget		Actual Month To Date	Actual Year To Date	Percent Spent	Variance - Favorable (Unfavorable)
	Original	Amended				
<u>General Government :</u>						
101-101 City Council	114,696	114,696	6,828	55,341	48.25%	59,355
101-103 Charter Review Committee	2,500	2,500	0	0	0.00%	2,500
101-172 City Manager	474,901	474,901	88,854	272,261	57.33%	202,640
101-191 Finance	587,942	587,942	77,017	268,992	45.75%	318,950
101-215 City Clerk	331,401	331,401	34,067	153,653	46.36%	177,748
101-228 Management Info. Services	448,021	448,021	27,349	223,515	49.89%	224,506
101-233 Purchasing	130,276	130,276	33,237	80,416	61.73%	49,860
101-253 City Treasurer	413,354	413,354	38,857	181,912	44.01%	231,442
101-254 City Income Tax	235,063	235,063	24,401	82,576	35.13%	152,487
101-257 City Assessor	544,375	544,375	41,900	195,058	35.83%	349,317
101-262 City Clerk-Elections	114,367	114,367	4,563	67,784	59.27%	46,583
101-265 City Hall & Grounds	431,258	431,258	23,781	187,465	43.47%	243,793
101-266 City Attorney	731,548	731,548	78,036	346,851	47.41%	384,697
101-270 Personnel	645,907	645,907	35,193	256,134	39.65%	389,773
101-278 Unallocated	879,799	879,799	40,560	386,170	43.89%	493,629
	6,085,408	6,085,408	554,643	2,758,128	45.32%	3,327,280
<u>Judicial:</u>						
101-299 Admin. Hearings Bureau	199,201	199,201	76,688	118,237	59.36%	80,964
	199,201	199,201	76,688	118,237	59.36%	80,964
<u>Public Safety:</u>						
101-301 Police	11,454,098	11,454,098	1,309,124	5,497,280	47.99%	5,956,818
101-311 OSHP Grant	0	0	0	4,256	N/A	(4,256) Note 2
101-320 Consortium Training	15,750	15,750	3,378	7,902	50.17%	7,848
101-321 In Service Training	3,185	3,185	-	-	0.00%	3,185
101-340 Fire Suppression	5,709,356	5,709,356	990,394	3,435,824	60.18%	2,273,532
101-350 Public Safety - Unallocated	2,107,885	2,107,885	135,168	1,070,370	50.78%	1,037,515
	19,290,274	19,290,274	2,438,064	10,015,632	51.92%	9,274,642
<u>Public Works :</u>						
101-442 Forestry	658,542	658,542	56,756	308,134	46.79%	350,408
101-444 Sidewalk Construction	55,707	55,707	0	32,937	59.13%	22,770
101-445 Drains at Large	78,779	78,779	404	43,412	55.11%	35,367
101-450 Street Lighting	601,899	601,899	28,891	141,132	23.45%	460,767
101-455 Weed Control	103,918	103,918	804	47,515	45.72%	56,403
101-465 Grounds Maintenance	467,230	467,230	4,086	120,953	25.89%	346,277
101-567 Cemeteries	358,075	358,075	24,496	165,138	46.12%	192,937
101-571 Tax Property Maintenance	226,695	226,695	6,343	115,289	50.86%	111,406
101-572 Civic Affairs	107,802	107,802	45,213	84,065	77.98%	23,737
	2,658,647	2,658,647	166,993	1,058,575	39.82%	1,600,072
<u>Community & Economic Development:</u>						
101-701 Planning	234,974	234,974	34,275	115,518	49.16%	119,456
101-728 Economic Development	132,400	132,400	25,910	87,299	65.94%	45,101
	367,374	367,374	60,185	202,817	55.21%	164,557

(Continued -)

City of Jackson, Michigan
General Fund Expenditure Summary
As of and For the Six Months Ended December 31, 2022
(Prepared on the Adopted Budget-Basis)

- Continued -

Function Department	2022/23 Budget		Actual Month To Date	Actual Year To Date	Percent Spent	Variance - Favorable (Unfavorable)
	Original	Amended				
<u>Recreation & Culture :</u>						
101-752 Parks, Rec. & Grnds. Admin.	305,867	305,867	6,105	166,256	54.36%	139,611
101-758 Lt. Nixon Memorial Pool	100,476	100,476	1,840	76,589	76.23%	23,887
101-771 Parks & Facilities Maintenance	836,134	836,134	(355,201)	629,691	75.31%	206,443
101-803 Historical District	12,790	12,790	1,345	5,673	44.35%	7,117
101-806 Diversity, Equity & Inclusion	306,235	306,235	27,340	122,071	39.86%	184,164
	1,561,502	1,561,502	(318,571)	1,000,280	64.06%	561,222
<u>Contributions to Other Funds:</u>						
101-965 Contributions to Other Funds	293,429	293,429	0	22,474	7.66%	270,955
Total General Fund Expenditures	30,455,835	30,455,835	2,978,002	15,176,143	49.83%	15,279,692
 <u>Funds Consolidated with the General Fund</u> <u>for Financial Reporting Purposes:</u>						
102 Budget Stabilization	25,000	25,000	0	0	0.00%	25,000

City of Jackson
All Other Funds - Expenditure Summary
As of and For the Six Months Ended December 31, 2022
(Prepared on the Adopted Budget-Basis)
- Continued -

Fund Type/Fund Name	2022/23 Budget		Actual Month To Date	Actual Year To Date	Percent Spent	Variance - Favorable (Unfavorable)
	Original	Amended				
<u>Permanent Funds :</u>						
151 Cemetery Perpetual Maint.	5,000	5,000	0	0	0.00%	5,000
155 Ella W. Sharp Endowment	23,850	23,850	0	0	0.00%	23,850
160 Lloyd E. Mount Endowment	7,000	7,000	0	0	0.00%	7,000
<u>Special Revenue Funds :</u>						
202 Major Street	24,731,248	24,731,248	557,983	4,677,941	18.92%	20,053,307
203 Local Street	3,898,044	3,898,044	71,029	635,954	16.31%	3,262,090
208 Ella W. Sharp Park Operating	986,741	986,741	67,500	525,138	53.22%	461,603
218 Affordable Housing	3,250,000	3,250,000	(6,565)	138,174	4.25%	3,111,826
245 Public Improvement	1,027,676	1,027,676	0	170,362	16.58%	857,314
246 Cortland St. Redev. Project	2,520,493	2,520,493	1,909	12,570	0.50%	2,507,923
249 Building Department	597,332	597,332	78,262	282,710	47.33%	314,622
251 Housing Code Enforcement	1,156,790	1,156,790	183,472	545,546	47.16%	611,244
252 Building Demolitions	406,815	406,815	3,800	61,066	15.01%	345,749
265 Drug Law Enforcement	16,702	16,702	3,075	9,737	58.30%	6,965
272 SAFER Grant	524,760	524,760	0	150,978	28.77%	373,782
273 Project Safe Neighborhoods	120,969	120,969	5,928	35,435	29.29%	85,534
275 Byrne/JAG Programs	0	49,361	0	27,500	N/A	21,861
279 American Rescue Plan Act	200,000	200,000	5,600	22,918	11.46%	177,082
296 Recreation Activity	206,248	206,248	25,305	193,126	93.64%	13,122
297 Recreation Millage Program	657,274	657,274	78,720	338,293	51.47%	318,981
<u>Debt Service Funds :</u>						
308 2020 Capital Improvement D/S	223,702	223,702	0	16,851	7.53%	206,851
352 2017 Mich. Trans. Fund D/S	761,890	761,890	0	73,445	9.64%	688,445
367 2021 City Hall Refunding D/S	729,581	729,581	0	18,290	2.51%	711,291
385 2016 Capital Improvement D/S	144,087	144,087	0	139,630	96.91%	4,457
386 2018 Capital Improvement D/S	1,410,000	1,410,000	0	292,250	20.73%	1,117,750
389 2017 BRA TIF Refunding D/S	420,556	420,556	0	107,778	25.63%	312,778
391 2021 BRA TIF Refunding D/S	772,512	772,512	0	32,256	4.18%	740,256
394 2001 DDA TIF D/S	2,735,750	2,735,750	0	0	0.00%	2,735,750
395 2019 DDA TIF Refunding D/S	209,573	209,573	0	84,787	40.46%	124,786
<u>Capital Projects Funds :</u>						
401 Capital Projects	1,955,898	1,955,898	0	29,893	1.53%	1,926,005
402 Water Equip. and Replacemt.	9,825,900	9,825,900	197,574	1,086,221	11.05%	8,739,679
403 Lead Service Line Replacement	1,661,966	1,661,966	19,058	56,048	3.37%	1,605,918
404 Sanitary Sewer Maint.	399,931	399,931	10,097	172,912	43.24%	227,019
405 Sanitary Sewer Replacement	1,902,121	1,902,121	28,825	186,618	9.81%	1,715,503
406 Wastewater Equip. Replacemt.	17,594,940	17,594,940	17,064	489,800	2.78%	17,105,140
407 2022 Sewer Sys. Project Const.	0	0	2,508	69,138	N/A	(69,138) Note 2
488 MLK Corridor Improvemt. Authority	10,000	10,000	10,075	42,540	425.40%	(32,540) Note 2
489 Brownfield Redevelopmt. Auth.	1,450,079	1,450,079	3,393	157,892	10.89%	1,292,187
494 DDA Project	2,947,323	2,947,323	0	84,787	2.88%	2,862,536

(Continued -)

City of Jackson
All Other Funds - Expenditure Summary
As of and For the Six Months Ended December 31, 2022
(Prepared on the Adopted Budget-Basis)

- Continued -

Fund Type/Fund Name	2022/23 Budget		Actual Month To Date	Actual Year To Date	Percent Spent	Variance - Favorable (Unfavorable)	
	Original	Amended					
<u>Enterprise Funds :</u>							
514	Auto Parking System	247,011	247,011	0	22,085	8.94%	224,926
518	Parking Assessment	303,267	303,267	13,262	120,851	39.85%	182,416
519	Cooper/Francis Parking Deck	283,775	283,775	2,939	27,747	9.78%	256,028
590	Sewer	18,162,790	18,162,790	631,741	3,662,741	20.17%	14,500,049
591	Water	19,257,736	19,257,736	1,350,787	6,092,118	31.63%	13,165,618
<u>Internal Service Funds :</u>							
641	Public Works Administration	477,472	477,472	34,817	162,947	34.13%	314,525
642	Engineering Administration	328,453	328,453	32,565	132,181	40.24%	196,272
643	Local Site Remed. Revolving	20,000	20,000	0	22,500	112.50%	(2,500) Note 2
661	Motor Pool and Garage	2,881,943	2,881,943	112,048	673,251	23.36%	2,208,692
676	Workers' Compensation	183,900	183,900	27,457	158,111	85.98%	25,789
677	Self-Insured Health Care	5,680,600	5,680,600	416,538	2,705,009	47.62%	2,975,591
<u>Trust & Agency Funds :</u>							
703	County & School Tax Collection	65,000	65,000	0	0	0.00%	65,000
731	Employees' Retirement System	4,220,000	4,220,000	302,043	1,956,495	46.36%	2,263,505
732	Policemen's/Firemen's Pension	548,000	548,000	42,428	263,467	48.08%	284,533
734	Police./Fire. Pension-345	7,640,000	7,640,000	467,566	2,385,705	31.23%	5,254,295
736	Public Employee Health Care	10,000	10,000	2,043	4,119	41.19%	5,881
<u>Special Assessment Funds :</u>							
852	2020 Special Assessment D/S	161,335	161,335	0	152,200	94.34%	9,135
895	Special Assessment	2,055,241	2,055,241	0	432,202	21.03%	1,623,039

City of Jackson
All Funds - Revenue Summary
As of and For the Six Months Ended December 31, 2022
(Prepared on the Adopted Budget-Basis)

Fund/Fund Name	2022/23 Budget		Actual Month To Date	Actual Year To Date	Percent Collected	
	Original	Amended				
<u>General Fund :</u>						
Property Taxes	10,423,356	10,423,356	395,954	9,346,153	89.67%	
Income Taxes	10,500,000	10,500,000	175,928	5,374,867	51.19%	
State Revenue Sharing	5,028,914	5,028,914	910,497	1,893,376	37.65%	
Licenses & Permits	367,025	367,025	12,801	120,889	32.94%	
Federal Grants	1,346,427	1,346,427	1,607	191,191	14.20%	
State Grants	3,185	3,185	0	2,628	82.51%	
Charges For Goods & Services	1,294,072	1,294,072	38,172	215,062	16.62%	
Fines & Forfeits	377,094	377,094	72,789	267,266	70.88%	
Investment Income	115,000	115,000	23,588	113,776	98.94%	
Contributions From Other Funds	120,000	120,000	0	5,829	4.86%	
Contributions From Local Units	12,500	12,500	6,020	16,920	135.36%	
Miscellaneous	225,323	225,323	13,314	175,495	77.89%	
Total General Fund Revenues	29,812,896	29,812,896	1,650,670	17,723,452	59.45%	
<u>Funds Consolidated with the General Fund</u>						
<u>for Financial Reporting Purposes:</u>						
102	Budget Stabilization	25,000	25,000	1,212	5,204	20.82%
<u>Permanent Funds :</u>						
151	Cemetery Perpetual Maint.	37,000	37,000	4,829	16,459	44.48%
155	Ella W. Sharp Endowment	23,850	23,850	0	0	0.00%
160	Lloyd E. Mount Endowment	7,000	7,000	0	0	0.00%
<u>Special Revenue Funds :</u>						
202	Major Street	24,253,509	24,253,509	271,164	3,326,606	13.72%
203	Local Street	2,889,376	2,889,376	83,514	662,392	22.93%
208	Ella W. Sharp Park Operating	921,600	921,600	24	360,833	39.15%
218	Affordable Housing	3,250,000	3,250,000	0	0	0.00%
245	Public Improvement	1,269,500	1,269,500	47,203	1,131,347	89.12%
246	Cortland St. Redev. Project	2,500,000	2,500,000	0	(473)	-0.02%
249	Building Department	497,500	497,500	21,489	262,568	52.78%
251	Housing Code Enforcement	1,157,500	1,157,500	43,193	1,035,877	89.49%
252	Building Demolitions	407,465	407,465	23,205	46,741	11.47%
265	Drug Law Enforcement	15,610	15,610	55	254	1.63%
272	SAFER Grant	524,760	524,760	0	150,978	28.77%
273	Project Safe Neighborhood	120,969	120,969	7,101	28,394	23.47%
275	Byrne/JAG Programs	0	49,361	0	27,500	55.71%
279	American Rescue Plan Act	200,000	200,000	0	15,722,413	7861.21%
296	Recreation Activity	208,000	208,000	14,811	111,038	53.38%
297	Recreation Millage Program	676,000	676,000	300,259	301,867	44.65%
<u>Debt Service Funds :</u>						
308	2020 Capital Improvement D/S	223,702	223,702	0	16,851	7.53%
352	2017 Mich. Trans. Fund D/S	761,890	761,890	0	73,445	9.64%
367	2021 City Hall Refunding D/S	668,000	668,000	23,578	636,506	95.29%
385	2016 Capital Improvement D/S	144,087	144,087	0	139,630	96.91%
386	2018 Capital Improvement D/S	1,410,000	1,410,000	0	292,250	20.73%

Note 2

(Continued-)

City of Jackson
All Funds - Revenue Summary
As of and For the Six Months Ended December 31, 2022
(Prepared on the Adopted Budget-Basis)

- Continued -

Fund/Fund Name	2022/23 Budget		Actual Month To Date	Actual Year To Date	Percent Collected	
	Original	Amended				
<u>Debt Service Funds (Continued) :</u>						
389	2017 BRA TIF Refunding D/S	420,556	420,556	0	107,778	25.63%
391	2021 BRA TIF Refunding D/S	772,512	772,512	0	32,256	4.18%
394	2001 DDA TIF D/S	2,735,750	2,735,750	0	0	0.00%
395	2019 DDA TIF Refunding D/S	209,573	209,573	0	84,787	40.46%
<u>Capital Projects Funds :</u>						
401	Capital Projects	1,956,398	1,956,398	63	377	0.02%
402	Water Equip. and Replacem.	7,808,191	7,808,191	412,512	2,461,496	31.52%
403	Lead Service Line Replacement	2,637,759	2,637,759	89,285	531,791	20.16%
404	Sanitary Sewer Maintenance	399,931	399,931	10,097	172,912	43.24%
405	Sanitary Sewer Replacement	672,950	672,950	60,379	354,034	52.61%
406	Wastewater Equip. Replacem.	16,095,054	16,095,054	134,550	915,065	5.69%
407	2022 Sewer Sys. Project Const.	0	0	0	539,395	N/A
488	MLK Corridor Improvem. Authority	10,000	10,000	0	0	0.00%
489	Brownfield Redevelopmt. Auth.	1,559,350	1,559,350	2,240	10,605	0.68%
494	DDA Project	3,405,000	3,405,000	7,997	197,680	5.81%
<u>Enterprise Funds :</u>						
514	Auto Parking System	93,743	93,743	465	2,499	2.67%
518	Parking Assessment	221,288	221,288	46,578	181,745	82.13%
519	Cooper/Francis Parking Deck	11,050	11,050	948	8,602	77.85%
590	Sewer	6,949,219	6,949,219	(6,333)	3,094,835	44.54%
591	Water	15,234,895	15,234,895	(864,206)	5,857,851	38.45%
<u>Internal Service Funds :</u>						
641	Public Works Administration	399,794	399,794	39,363	179,514	44.90%
642	Engineering Administration	265,891	265,891	27,979	139,637	52.52%
643	Local Site Remed. Revolving	67,950	67,950	329	1,458	2.15%
661	Motor Pool and Garage	2,823,832	2,823,832	172,257	671,331	23.77%
676	Workers' Compensation	185,000	185,000	16,185	76,254	41.22%
677	Self-Insured Health Care	5,940,600	5,940,600	500,783	2,522,756	42.47%
<u>Trust & Agency Funds :</u>						
703	County & School Tax Collection	65,000	65,000	7,332	28,081	43.20%
731	Employees' Retirement System	6,040,000	6,040,000	(757,026)	1,319,636	21.85%
732	Policemen's/Firemen's Pension	561,185	561,185	(99,474)	284,772	50.74%
734	Police./Fire. Pension-345	9,629,911	9,629,911	(1,309,062)	3,937,910	40.89%
736	Public Employees Health Care	230,000	230,000	300,986	101,460	44.11%
<u>Special Assessment Funds :</u>						
852	2020 Special Assessment D/S	161,335	161,335	0	152,200	94.34%
895	Special Assessment	2,055,241	2,055,241	1,208	284,567	13.85%

Note 2

City of Jackson
Notes to Revenue & Expenditure Summaries
As of and For the Six Months Ended December 31, 2022
(Prepared on the Adopted Budget-Basis)

Note 1: Revenues do not include budgeted appropriations from fund balance. These appropriations, together with budgeted revenues, are sufficient to fund budgeted expenditures, in accordance with State law.

Note 2: A Budget Amendment is pending to correct this variance.

JACKSON

Founded 1829

CITY COUNCIL MEETING MINUTES

Tuesday, January 24, 2023

1. CALL TO ORDER:

The Jackson City Council met in regular session in Council Chambers and was called to order at 6:30 p.m. by Mayor Daniel Mahoney.

2. PLEDGE OF ALLEGIANCE AND INVOCATION:

Council joined in the Pledge of Allegiance. Invocation was given by Fifth Ward Councilmember Karen Bunnell.

3. ROLL CALL:

Present: Mayor Daniel Mahoney, Vice Mayor Arlene Robinson, Second Ward Councilmember Freddie Dancy, Third Ward Councilmember Angelita Gunn, Fifth Ward Councilmember Karen Bunnell, and Sixth Ward Councilmember Will Forgrave.

Absent: Fourth Ward Councilmember Laura Dwyer Schlecte.

Also present: City Manager Jonathan Greene, City Attorney Matthew Hagerty, City Clerk Andrea Muray, City Assessor Jason Yoakam, Chief Equity Officer John Willis, Director of Parks and Recreation Kelli Hoover, Director of Police and Fire Services Elmer Hitt, City Engineer Jon Dowling, and Director of Community Development Shane LaPorte.

4. ADOPTION OF AGENDA:

Motion: Adopt the agenda.

Moved by: Angelita Gunn

Seconded by: Karen Bunnell

Aye Daniel Mahoney, Freddie Dancy, Angelita Gunn, Karen Bunnell, and Will Forgrave

Carried 5-0

5. PRESENTATIONS/PROCLAMATIONS:

5.1 Hotel Hayes update from the Jeffers Group

Motion: Add item 10.5 to the agenda

Moved by: Angelita Gunn

Seconded by: Karen Bunnell

Aye Daniel Mahoney, Arlene Robinson, Freddie Dancy, Angelita Gunn, Karen Bunnell, and Will Forgrave

Carried 6-0

6. PUBLIC HEARINGS:

Motion: Open the public hearing to receive citizen comment on the City's housing and community development needs.

Moved by: Angelita Gunn

Seconded by: Freddie Dancy

Aye Daniel Mahoney, Arlene Robinson, Freddie Dancy, Angelita Gunn, Karen Bunnell, and Will Forgrave

Carried 6-0

6.1 **Conduct a Public Hearing to Receive Citizen Comment on the City's Housing and Community Development Needs**

Comments were received regarding rental housing needs and homeless prevention efforts.

Motion: Close the public hearing.

Moved by: Freddie Dancy
Seconded by: Arlene Robinson

Aye Daniel Mahoney, Arlene Robinson, Freddie Dancy, Angelita Gunn, Karen Bunnell, and Will Forgrave

Carried 6-0

7. CITIZEN COMMENTS:

Citizen comments were heard and the meeting continued.

8. PETITIONS & COMMUNICATION FROM CITY STAFF AND OTHER GOVERNMENTAL ENTITIES:

8.1 Accept and Place on File, the CDBG, HOME and CDBG-CV Homeless Prevention financial summaries through December 31, 2022.

Motion: Accept and place on file the CDBG, HOME, and CDBG-CV Homeless Prevention financial summaries through December 31, 2022.

Moved by: Angelita Gunn
Seconded by: Freddie Dancy

Aye Daniel Mahoney, Arlene Robinson, Freddie Dancy, Angelita Gunn, Karen Bunnell, and Will Forgrave

Carried 6-0

9. CONSENT CALENDAR:

Motion: Approve the Consent Calendar.

Moved by: Freddie Dancy
Seconded by: Will Forgrave

Aye Daniel Mahoney, Arlene Robinson, Freddie Dancy, Angelita Gunn, Karen Bunnell, and Will Forgrave

Carried 6-0

- 9.1 **Minutes of the Regular Meeting of January 10, 2023**
Approve the minutes of the regular City Council Meeting of January 10, 2023
- 9.2 **Release of Jackson Police Department K9 to Det. Michael Galbreath**
Approve resolution authorizing the release of Jackson Police Department K9 'Gleeson' to Det. Michael Galbreath.
- 9.3 **Local Governing Body Resolution for Charitable Gaming License**
Approve resolution supporting the request from Lean Rocket Lab to be recognized as a nonprofit organization for the purpose of obtaining a charitable gaming license.
- 9.4 **Accept with regret, the resignation of Kenneth Robinson from the Affordable Housing Development Board**
- 9.5 **Appointment to the Affordable Housing Development Board**
Approve the Mayor's recommendation to appoint Toby Berry to the Affordable Housing Development Board for a five-year term, beginning immediately and ending on December 31, 2027.
- 9.6 **Appointment to the Environmental Commission**
Approve the Mayor's recommendation to appoint Conner Wood as the City Planning Commission's representative on the Environmental Commission for a concurrent term, beginning immediately and ending on December 31, 2025.
- 9.7 **Appointment to the Historic District Commission**
Approve the Mayor's recommendation to appoint Jacob Stressman to the Historic District Commission for a term of three-years beginning immediately and ending on December 31, 2025.

9.8 **Appointment to the Local Development Finance Authority**

Approve the Mayor's recommendation to appoint Finance Director Heather Ehnis to the Local Development Finance Authority/Brownfield Redevelopment Authority for a four-year term, beginning immediately and ending on June 3, 2026.

10. OTHER BUSINESS:

10.1 **Evaluate City Homeless Efforts (Discussion)**

City Manager Jonathan Greene provided an update on the homeless efforts.

10.2 **Second Reading/Final Adoption Ordinance No. 2023-01**

Recommendation: *Approve the second reading/final adoption of an ordinance amending Chapter 18 - Offenses, Article VI - Offenses Against Public Morals, Division 2, Marihuana and Drug Paraphernalia to Correct Section 18-156.*

Motion: Approve the second reading and final adoption of Ordinance No. 2023-01.

Moved by: Angelita Gunn

Seconded by: Will Forgrave

Aye Daniel Mahoney, Arlene Robinson, Angelita Gunn, Karen Bunnell, and Will Forgrave

Nay Freddie Dancy

Carried 5-1

10.3 **Second Reading/Final Adoption Ordinance No. 2023-02**

Recommendation: *Approve the second reading/final adoption of an ordinance amending Chapter 2, Article IV of the City of Jackson Code of Ordinances to revise the record disposal schedule for tax rolls and special assessment ledgers.*

Motion: Approve the second reading and final adoption of

Ordinance No. 2023-02.

Moved by: Angelita Gunn

Seconded by: Will Forgrave

Aye Daniel Mahoney, Arlene Robinson, Freddie Dancy, Angelita Gunn, Karen Bunnell, and Will Forgrave

Carried 6-0

10.4 **Second Reading/Final Adoption Ordinance No. 2023-03**

Recommendation: *Approve the second reading/final adoption of an ordinance amending Chapter 28 - Zoning of the City of Jackson Code of Ordinances.*

Motion: Approve the second reading and final adoption of Ordinance No. 2023-03.

Moved by: Will Forgrave

Seconded by: Karen Bunnell

Aye Daniel Mahoney, Arlene Robinson, Freddie Dancy, Angelita Gunn, Karen Bunnell, and Will Forgrave

Carried 6-0

10.5 **Contract Extension - Hayes Hotel**

Motion: Direct the City Manager and City Attorney to execute an extension of the previously executed purchase agreement dated April 11, 2022 between the City and J. Jeffers & Co. extended to December 31, 2023

Moved by: Will Forgrave

Seconded by: Angelita Gunn

Aye Daniel Mahoney, Arlene Robinson, Freddie Dancy, Angelita Gunn, Karen Bunnell, and Will Forgrave

Carried 6-0

11. NEW BUSINESS:

11.1 Approval of First Extension of the 2022 As Needed Materials Testing Services Contract

Recommendation: *Approval of the first extension of the 2022 As Needed Materials Testing Services Contract with Professional Services Industries (PSI), Inc. of Lansing, Michigan in the estimated amount of \$125,000.00, and authorization for the Mayor and City Clerk to execute the appropriate document(s) in accordance with the Purchasing Agent.*

Motion: Approve the first extension of the 2022 As Needed Material Testing Services Contract in the amount of \$125,000.00.

Moved by: Freddie Dancy

Seconded by: Will Forgrave

Aye Daniel Mahoney, Arlene Robinson, Freddie Dancy, Angelita Gunn, Karen Bunnell, and Will Forgrave

Carried 6-0

11.2 Overhead Doors Project at Jackson Fire Department Station #1

Recommendation: *Accept bid by Overhead Door Company for Fire Department Station #1.*

Motion: Approve overhead doors project at Jackson Fire Department Station #1

Moved by: Karen Bunnell

Seconded by: Arlene Robinson

Aye Daniel Mahoney, Arlene Robinson, Freddie Dancy, Angelita Gunn, Karen Bunnell, and Will Forgrave

Carried 6-0

11.3 **Windows Update Project at Jackson Fire Department Station #1**

Recommendation: *Accept bid by R.W. Mercer for window replacement at Fire Department Station #1.*

Motion: Approve windows update project at Jackson Fire Department Station #1

Moved by: Angelita Gunn

Seconded by: Will Forgrave

Aye Daniel Mahoney, Arlene Robinson, Freddie Dancy, Angelita Gunn, Karen Bunnell, and Will Forgrave

Carried 6-0

11.4 **Approval of Doug Jones and Chris Turner Community of Shapes Art Sculpture for the MLK Boulevard Roundabout and for the City Attorney and the Parks and Recreation Director to move forward with the artists agreement including delivery and installation. Not to exceed \$30,000.00**

Recommendation: *Approval of Doug Jones and Chris Turner Community of Shapes Art Sculpture for the MLK Boulevard Roundabout and for the City Attorney and the Parks and Recreation Director to move forward with the artists agreement including delivery and installation. Not to exceed \$30,000.00.*

Motion: Postpone item to the next meeting.

Moved by: Arlene Robinson

Seconded by: Will Forgrave

Aye Arlene Robinson and Will Forgrave

Nay Daniel Mahoney, Freddie Dancy, Angelita Gunn, and Karen Bunnell

Denied 2-4

Motion: Approval of Doug Jones and Chris Turner Community of Shapes Art Sculpture for the MLK Boulevard Roundabout and for the City Attorney and the Parks and Recreation Director to move forward with the artists agreement including delivery and installation for not to exceed \$30,000.00.

Moved by: Daniel Mahoney

Seconded by: Freddie Dancy

Aye Daniel Mahoney

Nay Arlene Robinson, Freddie Dancy, Angelita Gunn, Karen Bunnell, and Will Forgrave

Denied 1-5

Motion: Purchase the piece submitted that has the popular vote by Emcays with a not-to-exceed \$30,000 and recommendation to staff to request a budget be submitted before moving forward.

Moved by: Daniel Mahoney

Seconded by: Angelita Gunn

Aye Daniel Mahoney, Freddie Dancy, Angelita Gunn, Karen Bunnell, and Will Forgrave

Nay Arlene Robinson

Carried 5-1

12. CITY COUNCILMEMBER'S COMMENTS.

Mayor Mahoney, Councilmembers Bunnell, Forgrave, and Gunn

all offered comments.

Vice Mayor Robinson and Councilmember Dancy declined to offer comments.

13. MANAGER'S COMMENTS.

City Manager Jonathan Greene offered comments

14. ADJOURNMENT.

Motion: Adjourn

Moved by: Freddie Dancy

Seconded by: Karen Bunnell

Vote was done by voice with all in favor.

Mayor Mahoney adjourned the meeting at 9:08 p.m.

CAO

Mayor

----- Forwarded message -----

From: Bart Hawley <bhawley@jtv.tv>
Date: Mon, Jan 16, 2023 at 12:08 PM
Subject: Re: DDA
To: Jacqueline Austin <jacqaustin@7803800.com>

Hi Jacque,

Thanks for the note.

It's true...my schedule lately has prevented me from attending meetings regularly. Since we added the morning show, it has been more difficult. I have been giving this some thought and I feel my schedule doesn't allow me to give the attention to the position that the board deserves.

Regrettably, I feel I should give up the seat.

It has been a pleasure serving with you and I have greatly enjoyed my time on the board.

Cordially,

Bart

Bart Hawley
President
JTV, Inc.
152 W. Michigan Avenue
Jackson, MI 49201
517-795-8628
517-787-8817
Watch JTV anytime, anywhere at www.jtv.tv

January 19, 2023

Mayor Daniel Mahoney
And City Council Members
161 West Michigan Avenue
Jackson, MI 49201

RE: LOCAL OFFICERS COMPENSATION COMMISSION

Dear Mayor and City Council Members,

It has been my privilege to serve on the Local Officers Compensation Commission for almost forty (40) years. I have been fortunate enough to work on this commission with many different people over the years who love the Jackson community and were/are willing to volunteer their time and expertise to make the decisions that the LOCC is charged with making.

Even though I have enjoyed being part of the LOCC, it is now time for me to retire. Thank you so much for giving me the opportunity to be a small part of the many volunteer positions that are needed to make a community work well.

Yours truly,



Diane Cerqueira
311 South Bowen Street
Jackson, MI 49203

Residents in Action, Jackson Michigan
Homelessness Project Proposal for City of Jackson RFP – 01/11/22/22-01/26/23

Homelessness Project Narrative

Insights/Realizations

- We never anticipated that we would receive the high volume of inquiries that we have
- We surpassed the RFP guidelines to hotel 25 unique individuals/families within 3 days (in Dec 2022) and the waiting list has continued to grow; over 140 on the waiting list now.
- We are currently at full capacity so we have closed the new inquiry process and have halted the assessment process
- We have refocused our efforts solely on those currently in the hotel to ensure that all paperwork is documented, assessments are completed and that their needs are priority.
- New individuals/families had a standardized process for placement but we had to circle back to those who were initially placed by the City to ensure that all requested documentation is/was updated as applicable. Some are no longer at the hotel though so what we gather from who the City initially placed may be limited in comparison to what we have gathered for who RiA placed.
- We posted the status on the Residents in Action Facebook Page that we were closed to new inquiries but people are still calling, many of which who are continuing to be referred by local help organizations and agencies and many who are call backs from when they initially called. It is heartbreaking to tell people we are at full capacity when they have nowhere to go, no support system and no other resources to tap in to
- We now have 36 unique individuals/families currently placed in hotels. We have helped over

Barriers/Gaps

- Access to funds/Develop Plan for future disbursements
 - The City's concept of fiduciary role is different from what we have worked with in the past. Cutting a lump sum check is not what we have experienced in a traditional fiduciary role. We like having the lump sum check because it gives us the immediate access needed to the funds, however, the manpower to do the accounting functions also warrants funds to manage those processes.
 - We would like to revisit this arrangement to specifically identify what we need in a fiduciary role to make this project successful or make a recommendation for one of alternative fiduciaries that we have utilized in the past.
 - At this point, the \$40,000 that was initially released has been exhausted and we have not yet processed any payments to RiA Staff and Backbone.
 - We need to pay the RiA Project staff for hours worked to date
 - We need the RiA Backbone Support portion of 5% to be released

- We have some recommendations for reallocating funds (please see budget summary)
- We still need a daytime warming center (very grave need)
 - Jackson Interfaith Shelter is 11:00PM-6:00AM but conditional pending weather temp each day
 - No one else covers 8:00AM-11:00PM except Home of New Vision Resource Center and Engagement Center but that is for Recovery support and crisis.
- Generating a Report every two weeks seems to be excessive (8 reports) considering that this is a 15- week project. We have 2-year projects for double the funds that are not that excessive. Is an one pager and/or a verbal check in sufficient and/or a Feb report, March report and then a final report acceptable?

Successes

- We have continued to surpass what was initially asked of us as it relates to identifying and getting people in hotels
- Local businesses are still stepping up to donate food and/or give discounts and our hope is to work with the Jackson Business Chamber to enhance the options
- Some people have been added to the Section 8 list, have secured stable housing at South Ridge Park, been moved up on the Jackson Housing Commission list, have completed applications for other housing complexes, etc.
- We have received Thank you texts and calls from people who have made doctor's appointments, applied for jobs, taking their medication regularly and doing things that they knew they should have been doing all along but could not due to the stresses of being homeless. It is easier to prioritize daily life activities when you don't have to worry about where you are going to sleep and eat from day to day
- We have drafted verification letters so Community Action Agency can complete assessments and add individuals/families to the Section 8 list.

Next Steps

- Our plan is to continue to house who we have and continue to connect them to resources as applicable.
- If there are openings, we will still fill the gaps from the existing waiting list.
- We have drafted a projection plan to maximize the hotel dollars and to help the most people that we can. If the requested reallocations are approved that will help is assist more families as well.

Homelessness Project Data Tracking

Demographic Snap Shot - as of 01/26/23 (Family Make-up)

Row Labels	Count of Single/Couple/Family	%
Couple	10	4.72%
Family	53	25.00%
Single	88	41.51%
N/A	3	1.42%
Unknown/TBD	58	27.36%
Grand Total	212	

Demographic Snap Shot - as of 01/26/23 (Minors in Family)

Row Labels	Count of Families with Minors in Household	%
No	108	51.18%
Yes (@ 110 kids impacted)	48	22.75%
Unknown	51	24.17%
N/A	4	1.90%
Grand Total	211	

Demographic Snap Shot - as of 01/26/23 (Gender Breakdown) ***Some couples counted individually***

Row Labels	Count of Gender	%
Female	113	48.71%
Male	96	41.38%
N/A	3	1.29%
Nonbinary	1	0.43%
Unknown	19	8.19%
Grand Total	232	

Demographic Snap Shot - as of 01/26/23 (Race)

Row Labels	Count of Race	%
Unknown	89	42.18%
Caucasian	81	38.39%
African American	27	12.80%
Bi-Racial	4	1.90%
Hispanic and Caucasian	2	0.95%
American	1	0.47%
Half Cherokee Indian/Half Caucasian	1	0.47%
Human	1	0.47%
Indian	1	0.47%
Native Indian	1	0.47%
N/A	3	1.42%
Grand Total	211	

Residents in Action, Jackson Michigan
Homelessness Project Proposal for City of Jackson RFP – 01/11/22/22-01/26/23

12/21/22 - 01/10/23 (Living Situation)

Row Labels	Count of Living Situation Status	%
Car	16	22.22%
Condemned House	2	2.78%
Family	2	2.78%
Friend	6	8.33%
Hotel	16	22.22%
Street	29	40.28%
Tent	1	1.39%
Trailer	1	1.39%
Grand Total	72	Includes partial assessment data

01/11/23-01/24/23 (Living Situation)

Row Labels	Count of Living Situation Status	%
Car	21	9.95%
Condemned House	2	0.95%
Family/Friend	15	7.11%
Hotel	25	11.85%
Street/Tent	79	37.44%
Trailer	1	0.47%
Porch	2	0.95%
N/A	3	1.42%
Unknown/TBD	62	29.38%
Duplicate	1	0.47%
Grand Total	211	

- 139 more demographics classified over the last two weeks
- Combined Family/Friend category
- Combined Street/Tent
- Added Porch
- Unknown/TBD represents those we have not assessed who did not disclose where they were living when they called initially

Residents in Action, Jackson Michigan
Homelessness Project Proposal for City of Jackson RFP – 01/11/22/22-01/26/23

Homelessness Project Data Tracking

12/21/22 - 01/10/23 (Hotel Placement Status)

Hotel Placement Status	Count of RiA TRACKING
Hotel Placement - Declined - Travel Lodge	1
Hotel Placement - Left without notice - Travel Lodge	1
Hotel Placement - No Show - Travel Lodge	2
Hotel Placement - Successful - America's Best	8
Hotel Placement - Successful - Travel Lodge	28
Hotel Placement Discharged/Revoked - Travel Lodge	10
Waiting List	103
Total Lodged to date	47
Grand Total	153

01/11/23 - 01/26/23 (Hotel Placement Status)

Row Labels	Count of RiA TRACKING
Hotel Placement - Declined - Travel Lodge	2
Hotel Placement - Left without notice - Travel Lodge	1
Hotel Placement - No Show - Travel Lodge	5
Hotel Placement - Successful - America's Best	15
Hotel Placement - Successful - Travel Lodge	31
Hotel Placement Discharged/Revoked - Travel Lodge	8
Out of Area	1
Misc Inquiry	4
Waiting List	145
Total Lodged to date	56
Grand Total	212

- 59 additional homelessness inquiries over the last two weeks

Residents in Action, Jackson Michigan
Homelessness Project Proposal for City of Jackson RFP – 01/11/22/22-01/26/23

12/21/22 - 01/10/23 (Assessment Status)

Assessment Statuses	Count of Assessment Status
Assessment Completed	54
Assessment Declined	1
Assessment Not Completed - Initial or Subsequent Outreach made	54
Assessment Not Completed - Make Initial Contact	2
Assessment Not Completed - No longer at Hotel	9
Assessment Not Completed - Priority because of hotel placement (Partial)	22
Misc Inquiry	1
Missing, Non-working or Disconnected Contact info	10
Grand Total	153

Assessed	Count of Single/Couple/Family	%
Couple	6	10%
Family	26	43%
Single	29	47%
Grand Total	61	

01/11/23 - 01/26/23 (Assessment Status)

Row Labels	Count of Assessment Status
Assessment Completed	66
Assessment Declined	2
Assessment Not Completed - Initial or Subsequent Outreach made	53
Assessment Not Completed - Make Initial Contact	45
Assessment Not Completed - No longer at Hotel	8
Assessment Not Completed - Priority because of hotel placement	26
Assessment Not Completed - Missing, Non-working or Disconnected Contact info	8
N/A	4
Grand Total	212

Assessed	Count of Single/Couple/Family	%
Couple	4	6.06%
Family	29	43.94%
Single	33	50.00%
Grand Total	66	

- 100% of those assessed made less than \$40K a year

We are still collecting authorization of release forms, the City form and income verification forms as well as connecting to resources

Tashia M. Carter, MAOM, BBL, Executive Director Residents in Action
 915 Orchard Pl Jackson, MI 49203
 (517) 745-9459 Tcarter.riaservices@gmail.com

Homelessness Project Debit Summary as of 01/26/23

Category	Debit/Credit	
Hotel	\$ 40,810.73	
Food	\$ 1,442.67	
Gas	\$ 389.41	\$ 749.41
Supplies	\$ 250.00	
Transport	\$ 110.00	
Staff	\$ 4,550.00	
Grand Total	\$ 47,552.81	

Budget Item	Hours	Rate	Budget	Used/Billed	Hours Balance	Budget Amount Balance	Notes
<i>Homelessness Support Specialists (@44 hours per week) (Community-Based Workers for Basic Needs, Coordination and Navigation w/Organizations/Agencies).</i>	572	\$ 25.00	\$ 14,300.00	182	390 \$4,550.00	\$ 9,750.00	Hours that need to be expensed for time period 12/21/23-01/21/23 (no funding left to pay staff)
Operational/Data Lead	50	\$ 125.00	\$ 6,250.00	0	50	\$ 6,250.00	No hours have been expensed yet; we want to reallocate these dollars
Performance Advisor	20	\$ 150.00	\$ 3,000.00	0	20	\$ 3,000.00	No hours have been expensed yet; we want to reallocate these dollars
Hotel Room Costs (room cost + occupancy tax for 30 nights/budgeted for 23 unique families/individuals)	690 nights	\$ 125.00	\$ 86,250.00	\$ 40,810.73	N/A	\$ 45,439.27	Please refer to the future projections sheet
Food/food cards (\$100.00 per wk for lodged + community funds)	N/A		\$ 40,000.00	\$ 1,442.67	N/A	\$ 38,557.33	If we can develop a plan with businesses we may want to reallocate these dollars to more hotel funding
Clothing and warming supplies, basic needs, household supplies, Covid needs, & transportation (gas cards and bus cards), application and legal document fees, etc.		\$ 20,000.00	\$ 749.41	N/A	\$ 19,250.59	We have a list of needs but need more funding released to pay for the items	
Office supplies and technology		\$ 1,000.00	\$ -	N/A	\$ -	We have a list of needs but need more funding released to pay for the items	
Rent, Utilities, Storage, etc.		\$ 2,000.00	\$ -	N/A	\$ -		
Total				\$ 172,800.00	172,800.00	\$ 122,247.19	
Fiduciary and RIA Backbone Support (15%)	Fiduciary	10%	\$ 17,280.00	\$ -	N/A	\$ 17,280.00	
	RIA Backbone Support	5%	\$ 8,640.00	\$ -	N/A	\$ 8,640.00	Would like this to be released with the additional funding
Final Total			\$ 198,720.00	\$ -	N/A	\$ 148,167.19	

MEMO TO: Mayor and City Councilmembers
FROM: Jonathan Greene, City Manager
DATE: February 7, 2023
SUBJECT: **Award the contract to Michigan Agribusiness Solutions of LLC Saginaw, Michigan, for the hauling and land application of biosolids from the Wastewater Treatment Plant.**

Recommendation:

Award the contract to Michigan Agribusiness Solutions of LLC Saginaw Michigan, for the hauling and land application of biosolids removal contract at a price of \$0.041 per gallon.

Attached is a report from Michael G. Osborn, Director of Public Works regarding the award for the contract referenced above.

Your consideration and concurrence is appreciated.

JG

DEPARTMENTAL REPORT

MEMO TO: Jonathan Greene, City Manager
FROM: Michael Osborn, Director of Public Works
DATE: February 7, 2023

RECOMMENDATION: Award the contract to Michigan Agribusiness Solutions of LLC Saginaw, Michigan, for the hauling and land application of bio solids from the Wastewater Treatment Plant.

SUMMARY

Award the contract to Michigan Agribusiness Solutions of LLC Saginaw, Michigan, for hauling and land application of bio solids at the Waste water treatment Plant. Michigan Agribusiness was the lowest bidder coming in at a cost of \$0.041 per gallon. The estimated annual cost for 2023 is \$260,000. The only other bid received was from Biotech Agronomics Inc. at cost \$0.0463 per gallon.

BUDGETARY CONSIDERATIONS

The funding for this contract is accommodated for in section 590-553-000-818.000 of the Sewer Fund Sludge Handling contractual services budget.

Company	Bid
Michigan Agribusiness Solutions LLC, Saginaw, Michigan	0.041 per Gallon
Biotech Agronomics Inc., Beulah, Michigan	0.0463 per gallon

Bid evaluation criteria is part of the Responsible Contractor Ordinance, which consists of the following components:

- A) Price (25%)
- B) Corporate Accountability (25%)
- C) Workplace Safety (25%)
- D) Workforce Development (15%)
- E) Social Equity (10%)

Company	A	B	C	D	E	Total
Michigan Agribusiness Solutions LLC	25	20	15	15	10	85
Biotech Agronomics Inc.	0	25	25	10	5	65

HISTORY, BACKGROUND and DISCUSSION

During the wastewater treatment process, biosolids are produced, and treated through an anaerobic digestion process, then stored in liquid form or dried in open air drying beds. These biosolids are then used as fertilizer and soil enhancement on agriculture lands. These biosolids must be tested regularly for contaminants and/or pollutants to ensure they meet the State and Federal Regulations for land application. If contaminants and/or pollutants remain above the State and Federal Regulatory levels, it may be determined that the biosolids cannot be land applied, therefore they will be hauled to a landfill for proper disposal.

Changes to the total amount of gallons to be hauled in recent years from the Wastewater Treatment Plant were made in the bid specifications going forward to better suit the needs of the Plant. Liquid biosolids hauling was increased from a minimum of 500,000 gallons to 1,000,000 gallons, and for the dry biosolids hauling was increased from a minimum of 300 cubic yards to 1,500 cubic yards. These increases were necessary to ensure that the appropriate amount of biosolids would be removed from the Wastewater Treatment Plant.

POSITIONS

I recommend we award the contract to Michigan Agribusiness Solutions of LLC Saginaw, Michigan, for the hauling and land application of bio solids from the Wastewater Treatment Plant at the cost of \$0.041 per gallon, for an estimated annual cost of \$260,000.

ATTACHMENTS

		MICHIGAN AGRIBUSINESS SOLUTIONS, LLC	BIOTECH AGRONOMICS, INC.
		3050 FREEWAY LANE SAGINAW, MI 48601	1651 BEULAH HIGHWAY BEULAH, MI 49617
Line	Description	TOTAL COST	TOTAL COST
1	Cost per gallon to pump/haul and land apply liquid biosolids	0.041	\$ 0.0463
2	Cost per cubic yard to load, haul and land apply dry biosolids	29.00	\$ 39.22
3	ALTERNATE PRICE: Cost per cubic yard to haul and land apply dry biosolids with City providing loader and operator	25.50	\$ 34.58

THE AMERICAN INSTITUTE OF ARCHITECTS



AIA Document A310

Bid Bond

Bond No.: 430419

KNOW ALL MEN BY THESE PRESENTS, that we BioTech Agronomics, Inc.

1651 Beulah Hwy, Beulah, MI 49617
as Principal, hereinafter call the Principal, and Merchants Bonding Company (Mutual)
P.O. Box 14498, Des Moines, Iowa 50306-3498

a corporation duly organized under the laws of the State of Iowa
as Surety, hereinafter called the Surety, are held and firmly bound unto City of Jackson, Michigan

161 W Michigan Avenue, Jackson, MI 49201
as Obligee, hereinafter called the Obligee, in the sum of Five Percent of Bid Amount

Dollars (\$ 5 %),
for the payment of which sum well and truly to be made, the said Principal and the said Surety, bind ourselves, our heirs, executors, administrators, successors and assigns, jointly and severally, firmly by these presents.

WHEREAS, the Principal has submitted a bid for Hauling and Land Application of Wastewater Biosolids for the City of Jackson.

NOW THEREFORE, if the Obligee shall accept the bid of the Principal and the Principal shall enter into a Contract with the Obligee in accordance with the terms of such bid, and give such bond or bonds as may be specified in the bidding or Contract Documents with good and sufficient surety for the faithful performance of such Contract and for the prompt payment of labor and materials furnished in the prosecution thereof, or in the event of the failure of the Principal to enter such Contract and give such bond or bonds, if the Principal shall pay to the Obligee the difference not to exceed the penalty hereof between the amount specified in said bid and such larger amount for which the Obligee may in good faith contract with another party to perform the Work covered by said bid, then this obligation shall be null and void, otherwise to remain in full force and effect.

Signed and sealed this 10th day of January 2023 XBX

BioTech Agronomics, Inc.

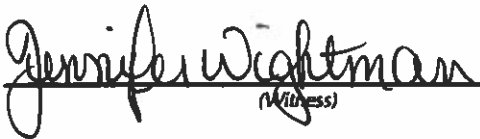
(Witness)

(Principal) (Seal)
Kevin Bonney (Title) President

Merchants Bonding Company (Mutual)
(Surety) (Seal)

Jason Rowe (Witness)

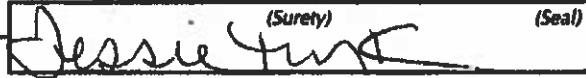
(Title) Attorney-in-Fact

MERCHANTS BONDING COMPANY, INC.

POWER OF ATTORNEY

Know All Persons By These Presents, that MERCHANTS BONDING COMPANY (MUTUAL) and MERCHANTS NATIONAL BONDING, INC., both being corporations of the State of Iowa, d/b/a Merchants National Indemnity Company (in California only) (herein collectively called the "Companies") do hereby make, constitute and appoint, individually,

Jessie Twork

their true and lawful Attorney(s)-in-Fact, to sign its name as surety(ies) and to execute, seal and acknowledge any and all bonds, undertakings, contracts and other written instruments in the nature thereof, on behalf of the Companies in their business of guaranteeing the fidelity of persons, guaranteeing the performance of contracts and executing or guaranteeing bonds and undertakings required or permitted in any actions or proceedings allowed by law.

This Power-of-Attorney is granted and is signed and sealed by facsimile under and by authority of the following By-Laws adopted by the Board of Directors of Merchants Bonding Company (Mutual) on April 23, 2011 and amended August 14, 2015 and adopted by the Board of Directors of Merchants National Bonding, Inc., on October 18, 2015.

"The President, Secretary, Treasurer, or any Assistant Treasurer or any Assistant Secretary or any Vice President shall have power and authority to appoint Attorneys-in-Fact, and to authorize them to execute on behalf of the Company, and attach the seal of the Company thereto, bonds and undertakings, recognizances, contracts of indemnity and other writings obligatory in the nature thereof."

"The signature of any authorized officer and the seal of the Company may be affixed by facsimile or electronic transmission to any Power of Attorney or Certification thereof authorizing the execution and delivery of any bond, undertaking, recognizance, or other suretyship obligations of the Company, and such signature and seal when so used shall have the same force and effect as though manually fixed."

In connection with obligations in favor of the Florida Department of Transportation only, it is agreed that the power and authority hereby given to the Attorney-in-Fact includes any and all consents for the release of retained percentages and/or final estimates on engineering and construction contracts required by the State of Florida Department of Transportation. It is fully understood that consenting to the State of Florida Department of Transportation making payment of the final estimate to the Contractor and/or its assignee, shall not relieve this surety company of any of its obligations under its bond.

In connection with obligations in favor of the Kentucky Department of Highways only, it is agreed that the power and authority hereby given to the Attorney-in-Fact cannot be modified or revoked unless prior written personal notice of such intent has been given to the Commissioner-Department of Highways of the Commonwealth of Kentucky at least thirty (30) days prior to the modification or revocation.

In Witness Whereof, the Companies have caused this instrument to be signed and sealed this 10th day of January, 2023.



MERCHANTS BONDING COMPANY (MUTUAL)
MERCHANTS NATIONAL BONDING, INC.
d/b/a MERCHANTS NATIONAL INDEMNITY COMPANY

By *Larry Taylor*
President

STATE OF IOWA
COUNTY OF DALLAS ss.

On this 10th day of January, 2023, before me appeared Larry Taylor, to me personally known, who being by me duly sworn did say that he is President of MERCHANTS BONDING COMPANY (MUTUAL) and MERCHANTS NATIONAL BONDING, INC.; and that the seals affixed to the foregoing instrument are the Corporate Seals of the Companies, and that the said instrument was signed and sealed in behalf of the Companies by authority of their respective Boards of Directors.



Kim Lee
Notary Public

(Expiration of notary's commission does not invalidate this instrument)

I, William Warner, Jr., Secretary of MERCHANTS BONDING COMPANY (MUTUAL) and MERCHANTS NATIONAL BONDING, INC., do hereby certify that the above and foregoing is a true and correct copy of the POWER-OF-ATTORNEY executed by said Companies, which is still in full force and effect and has not been amended or revoked.

In Witness Whereof, I have hereunto set my hand and affixed the seal of the Companies on this 10th day of January, 2023.



William Warner Jr.
Secretary

BioTech Agronomics, Inc.

Residual Management Company

1651 US 31 • Beulah • MI • 49617 • P: 231-882-7219 • F: 231-882-9690
www.biotechag.com

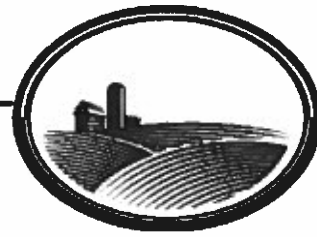

January 10, 2023

City of Jackson
161 W. Michigan Avenue
Jackson, Michigan 49201

RE: "HAULING AND LAND APPLICATION OF WASTEWATER BIOSOLIDS FOR THE CITY OF JACKSON"

Thank you for the opportunity to respond to your Bid solicitation. BioTech Agronomics, Inc. is a Michigan based Company and has been in the professional residuals management business for over 22 years.

We look forward to being able to work with you on this project.

If you have any questions please contact me at any time. We look forward to hearing from you.

Yours in Service,

A handwritten signature in black ink, appearing to read "Don Popma". The signature is fluid and cursive.

Don Popma
General Manager
BioTech Agronomics, Inc.
616.835.0100 cell
dpopma@biotechag.com

BIOTECH AGRONOMICS, INC IS AN EQUAL OPPORTUNITY EMPLOYER.

CHECKLIST FOR BID SUBMITTAL



BID BOND – If a bid bond is required, please submit your bid bond with your bid documents



PROPOSAL SHEETS – Please fill out and have notarized your proposal sheets



SAMS.GOV - Please register with SAM.GOV to be eligible to work on federally funded projects. Registration is free.

<https://sam.gov/content/entity-registration>

Please provide your sams.gov Unique Identity Number: _____
if you have received it.

PROPOSAL

TO: City Manager
c/o Purchasing Agent
City of Jackson, Michigan

Date: 1/10/2023

In compliance with your invitation for bids dated November 29, 2022 to perform
**HAULING AND LAND APPLICATION OF WASTEWATER BIOSOLIDS FOR
THE CITY OF JACKSON**

in the City of Jackson, the undersigned, a(n)

1. individual, resident of XXXXXX
doing business as _____
at _____
2. partnership, consisting of XXXXXX
and _____
under the firm name of _____
3. corporation by the name of BioTech Agronomics, Inc.
organized and existing under the laws of the State of Michigan
with offices at 1651 Beulah Highway Beulah, MI 49617
(strike inapplicable clauses)

hereby proposes to perform said work, strictly as specified in the bid documents at the prices set forth on the attached schedule of bid prices, upon receipt of written notice of acceptance of this bid within ninety (90) calendar days after opening of the bids at the time stated in said Invitation; to execute a properly completed contract in the form provided with the bid documents in accordance with this bid; to give bond with good and sufficient surety or sureties, satisfactory to the City Attorney of Jackson, for the faithful performance of said contract, for payment of labor and materials, and, if required, for maintenance of work; and to give such bond within ten (10) days after notice of award.

FEDERAL ID# 42-1535358

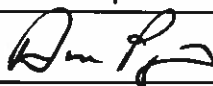
(Corporate Seal, if applicable) Name of Bidder: Don Popma
Signed By: 
Its: General Manager

BID SHEET

DATE:

PROPOSAL FOR: HAULING AND LAND APPLICATION OF WASTEWATER BIOSOLIDS FOR THE CITY OF JACKSON

TO: The Mayor and the City Council
City of Jackson, Michigan

Ladies and Gentlemen:

The Undersigned has examined the plans, specifications, and the location of the above described work, and is fully informed as to the conditions relating to its performance, and understands the quantities shown in the estimate and on the plans are accurate to the best belief and knowledge of the Engineer, but are not guaranteed.

The undersigned hereby proposes to furnish all equipment, materials, supplies, labor, and services necessary to commence and complete the project as described in the Contract Documents; and in strict conformity with the requirements of the Specifications and such other special provisions and supplemental specifications as may be a part of this proposal for the above described project at the following unit prices all labor, equipment and materials necessary for completion of the work, but not specifically listed as a pay item, will be deemed to be included in one or more of the pay items listed in the bid sheet.

Bidder has examined and carefully studied the Bidding Documents, other related data identified in the Bidding Documents, and the following Addenda, receipt of which is hereby acknowledged (list addenda by Addendum Number and Date):

Addendum No.	Date
_____	_____
_____	_____
_____	_____

SCHEDULE OF BID PRICES
NOTE: UNIT PRICES MUST BE LISTED AND SHALL GOVERN.

ITEM NO	DESCRIPTION	TOTAL COST
1	Cost per gallon to pump haul and land apply liquid biosolids	\$0.0463
2	Cost per cubic yard to load, haul and land apply dry biosolids	\$39.22
3	ALTERNATE PRICE: Cost per cubic yard to haul and land apply dry biosolids with City providing loader and operator.	\$34.58

Submitted Bid:	BioTech Agronomics, Inc.
Labor Costs:	Labor costs are included in the per gallon & cubic yard unit rates
Materials Costs:	Material costs are included in the per gallon & cubic yard unit rates
Equipment Costs:	Equipment costs are included in the per gallon & cubic yard unit rates
Possible Change Orders:	BioTech Agronomics, Inc may request if possible a reasonable fuel surcharge if the price of diesel fuel exceeds \$5.50 per gallon.

Bidder's Name:	BioTech Agronomics, Inc.
Address:	1651 Beulah Highway
City, State, Zip:	Beulah, Michigan 49617
Telephone:	231-882-7219
Fax:	231-882-9690

Email Address:	dpopma@biotechag.com	
Federal ID Number:	42-1535358	
Bid Signed By:	Don Popma	Print or Type
Title:	General Manager	

1. I am the person described in and who executed the foregoing bid and that the several matters stated are in all respects true.
2. That I am an employee of the firm or company described in and I am authorized to submit said bid.

By  its General Manager

CONTRACT COMPLIANCE

DATE: November 29, 2022
TO: All Bidders
FROM: City of Jackson
SUBJECT: CONTRACT COMPLIANCE

The Commission of the City of Jackson, on 12/19/72, passed a resolution committing the City to a policy and procedure regarding compliance to affirmative hiring practices by contracting agencies doing business with the City of Jackson, effective 12/20/72.

The purpose of the policy and procedure is to ensure that all citizens of our community have the opportunity for the equality of treatment in service and employment.

The City requests that all bidders who will be doing business with the City in the amount of \$5,000 or more during any fiscal year, shall comply with the provisions of the Contract Compliance Policy.

Bidders will be required to show an Equal Employment Opportunity Certificate of Compliance or demonstrate compliance with standards for equal employment opportunity established by state and federal statute.

City Council of Jackson, Michigan

CONTRACT COMPLIANCE

CERTIFICATION

Don Popma certifies that he/she/it will not discriminate against any employee or applicant for employment with respect to hire, tenure, term, conditions, or privileges or employment because race, religion or national origin, color, age, sex, height, weight, marital status, sexual orientation, gender identity, and physical or mental handicap.

In connection with this commitment Don Popma understands that he/she/it name will be reviewed by the State of Michigan, Department of Civil Rights for determination of its status as an awardable Bidder.

The undersigned hereby agrees that he/she/it will abide by the terms of any agreements made with the City of Jackson in order to achieve awardable status.

Dated: 1/10/2023

By: Don Popma
(Bidder's Name)

By: 
(Signature)

By: General Manager
(Title)

1651 Beulah Highway
Address

Beulah
City

Michigan 49617
State and Zip

NON-DISCRIMINATION CLAUSE FOR ALL CITY OF JACKSON CONTRACTS

In connection with the performance of this contract, the contractor agrees as follows:

1. The contractor will not discriminate against any employee/employer for employment because of race, religion or national origin, color, age, sex, height, weight, marital status, sexual orientation, gender identity, and physical or mental handicap. The contractor will take affirmative action to ensure that minority applicants are employed, and that employees are treated during employment without regard to their race, religion, color, national origin, age, sex, height, weight, marital status or handicap. Such action shall include, but not be limited to, the following: layoff or termination, rates of pay or other forms of compensation, selection for training, upgrading or promotion, transfer or recruitment.
2. The contractor will, in all solicitations or advertisements for employees placed by or on behalf of the contractor, state that all qualified applicants will receive consideration for employment without regard to race, religion, color, national origin, age, sex, height, weight, marital status or handicap. As a disclaimer, the contractor may state in the advertisement that he/she is an equal opportunity employer.
3. The contractor will furnish and file compliance reports with the City of Jackson as requested. Such reports shall elicit information as to the practices, policies, program and employment statistics for the contractor and said contractor shall permit access to all books, records and accounts regarding employment practices by agents and representatives of the City duly charged with investigative duties to assure compliance with this clause.
4. Breach of the covenants herein may be regarded as a material breach of the contract, or purchasing agreement.
5. The contractor will include, or incorporate by reference, the provisions of paragraphs (1) through (4) in every subcontract or purchase order unless exempted by the rules, regulations or orders of the Michigan Civil Rights Commission and will provide in every subcontract or purchase order that said provisions will be binding upon each subcontractor or seller.

EQUAL EMPLOYMENT OPPORTUNITY CERTIFICATION

The undersigned understands and agrees that, as a Contractor for services, there shall be no discrimination against any employee or applicant for employment because of race, religion or national origin, color, age, sex, height, weight, marital status, sexual orientation, gender identity, and physical or mental handicap, including but no limited to employment, upgrading, demotion, or transfer; recruitment or recruitment advertising; layoff or termination; rates of pay or other forms of compensation and selection for training.

The Contractor further agrees to the following:

- (a) It will assist and actively cooperate with the City in obtaining compliance of any subcontractors with the equal opportunity rules, regulations, and relevant orders.
- (2) It will furnish the City such information as might be required for the supervision of its compliance program, and will otherwise assist the City in the discharge of its responsibility for ensuring compliance.
- (3) In the event that the Contractor fails or refuses to comply with the equal opportunity regulations, the City may cause to be canceled, terminated, or suspended in whole or in part the contractual arrangement between the City and the Contractor.

NAME OF BIDDER: BioTech Agronomics, Inc.

ADDRESS: 1651 Beulah Highway
Beulah, MI 49617

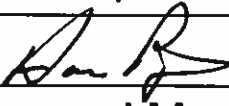
SIGNED BY: 

TITLE: General Manager

DATE: 1/10/2023

CERTIFICATION OF NONSEGREGATED FACILITIES

The bidder certifies that he does not maintain or provide for his employees any segregated facilities and do not permit his employees to perform their services at any location, under his control, where segregated facilities are maintained. The bidder certifies further that he will not maintain or provide for his employees any segregated facilities at any of his establishments, and that he will not permit his employees to perform their services at any location under his control where segregated facilities are maintained. The bidder agrees that a breach of this certification will be a violation of the Equal Opportunity clause in any contract resulting from acceptance of this bid. As used in this certification, the term "segregated facilities" means any waiting rooms, work areas, restrooms and washrooms, restaurants and other eating areas, time clocks, locker rooms and other storage or dressing areas, parking lots, drinking fountains, recreation or entertainment areas, transportation, and housing facilities provided for employees which are segregated by explicit directive or are in fact segregated on the basis of race, color, religion, or national origin, because of habit, local custom, or otherwise. The bidder agrees that (except where he has obtained identical certification from proposed subcontractors for specific time periods) he will obtain identical certification from proposed subcontractors prior to the award of subcontracts exceeding \$10,000 which are not exempt from the provisions of the Equal Opportunity clause, and that he will retain such certifications in his files.

Dated: 1/10/2023

By: Don Popma
(Bidder's Name)

By: 
(Signature)

By: General Manager
(Title)

1651 Beulah Highway
Address

Beulah
City

Michigan 49617
State and Zip

NON-COLLUSION AFFIDAVIT OF PRIME BIDDER

STATE OF Michigan
COUNTY OF Kent ss

Kelly Jo Paiz, being first duly sworn, deposed and says that:

1. He is Don Poma of BioTech Agromes Inc the Bidder that has submitted the attached bid;
2. He is fully informed respecting the preparation and contents of the attached bid and of all pertinent circumstances respected such bid;
3. Such bid is genuine and is not a collusive or sham bid;
4. Neither the said Bidder nor any of its officers, partners, owners, agents, representatives, employees or parties in interest, including this affiant, has in any way colluded, conspired, connived or agreed, directly or indirectly with any other Bidder, firm or person to submit a collusive or sham bid in connection with the contract for which the attached bid has been submitted or to refrain from bidding in connection with such contract, or has in any manner, directly or indirectly, sought by agreement or collusion or communication or conference with any other Bidder, firm or person to fix the price or prices in the attached bid or of any other Bidder, or to fix any overhead, profit or cost element of the bid price or the bid price of any other Bidder, or to secure through any collusion, conspiracy, connivance or unlawful agreement any advantage against the City of Jackson or any person interested in the proposed contract; and
5. The price or prices quoted in the attached bid are fair and proper and are not tainted by any collusion, conspiracy, connivance or unlawful agreement on the part of the Bidder or any of its agents, representatives, owners, employees, or parties in interest, including this affiant.

Dated: 1-3-23

By: Don Poma BioTech Agromes, Inc.
(Company)

By: General manager
(Title)

Subscribed and sworn to before me, a Notary Public, this 3 day of January, 2023.

[Signature]

Notary Public, _____ County,
My commission expires: _____

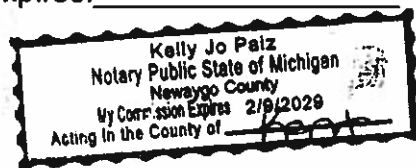

**RIGHT TO KNOW
CONTRACTOR RELEASE FORM**

I, Don Popma an authorized representative of BioTech Agronomics, Inc.

am aware that as a requirement to perform work for the City of Jackson on a contractual basis, I must have provided my employees with the basic training requirements of the HAZARD COMMUNICATION STANDARD as prescribed by the Michigan Right to Know amendments to Act 154 of the Public Acts of 1974 (Act 80, Public Acts 1986), prior to starting any work for the City. While engaged in working for the City, I will continue to comply with Michigan Right to Know Law until completion of the contract.

I am aware that if I bring any hazardous chemical to the City's work place, I must have available the MSDS for these chemicals, in a place accessible to all employees in the work place. If necessary, due to the "special protection information" requirement stated on the MSDS for the chemicals, I will provide all employees with any special training, special protective clothing or equipment necessary to eliminate or lessen the possible exposure to the hazardous chemical or chemicals.

By execution of this Release, the contractor acknowledges that he and all subcontractors and suppliers, will comply with all requirements of the HAZARD COMMUNICATION STANDARD. Further, the contractor shall hold harmless from and indemnify the City against all claims, suits, actions, costs, counsel fees, expenses, damages, judgements or decrees, by reason of his failure, or the failure of any subcontractor, suppliers, or any person employed under said contractor to comply with the requirements of Act 154 of the Public Acts of 1974 as amended.

Dated 1/10/2023



Signature



City of Jackson Ethics Disclosure Form Vendors and Contractors

Name Don Popma	Company BioTech Agronomics, Inc.
Telephone 231-882-7219	Email Address dpopma@biotechag.com

Contract or matter pending with the City:

I, **Don Popma**, being duly sworn, and pursuant to City of Jackson Ordinance No. 2015-18, I hereby disclose and swear to the following (check all that apply and provide details below):

- I, or my company's owners, members, major shareholders, or corporate officers, have a financial interest in a contract or matter pending before Jackson City Council.

- A relative¹ or immediate family member² of myself or my company's owners, members, major shareholders, or corporate officers has a financial interest in a contract or matter pending before a City office, department, board, or commission.

- I, or my company's owners, members, major shareholders, or corporate officers, have an interest in real or personal property that is subject to a decision by the City regarding the purchase, sale, lease, zoning, property improvements, NOORPR or FVA registration, a development agreement, or a special tax designation or abatement.
 Property address: _____
 Property interest: _____

- An immediate family member or relative of myself or my company's owners, members, major shareholders, or corporate officers, has a financial interest in real or personal property that is subject to a decision by the City regarding the purchase, sale, lease, zoning, property improvements, NOORPR or FVA registration, a development agreement, or a special tax designation or abatement.

¹ Relative means any spouse, domestic partner, great grandparents, step great grandparents, grandparents, step grandparents, sons, stepsons, daughters, step daughters, grandsons, step grandsons, granddaughters, step granddaughters, brothers, step brothers, sisters, step sisters, and in-laws of a Public Employee, the Mayor, an Elected Official, an Appointed Official, a member of a Board or Commission, a Contractor, or an Advisor of the City.

² Immediate family member means a Public Employee, the Mayor, an Elected Official, an Appointed Official, a member of a Board or Commission, a Contractor, or an Advisor's spouse, domestic partner, individual who lives in the Public Employee's household or an individual claimed by a Public Employee or a Public Employee's spouse as a dependent under the United States Internal Revenue Code at 26 USC 1, et seq.

Property address: _____

Property interest: _____

An immediate family member or relative of myself or my company's owners, members, major shareholders, or corporate officers, is employed by the City or making an application for employment to the City.

Relative name: _____

City Department: _____

I, or my company's owners, members, major shareholders, or corporate officers, have made campaign contributions in the last year to a candidate running for elective office with the City.

Name of Candidate: _____

Amount of Campaign Contribution: _____

The following entities and persons have a financial interest in the contract or matter identified above:

Additional information regarding any of the above:

None of the above apply.

Dated: 1-3-23

Dm P
Signature

STATE OF MICHIGAN)
) Kent) SS
COUNTY OF JACKSON)

The foregoing instrument was acknowledged before me this 3 day of January, 2023

By [Signature]

Kelly Jo Palz
Notary Public State of Michigan
Newaygo County
My Commission Expires 2/9/2029
Acting in the County of Kent



Responsible Contractor Ordinance

Below are twenty-nine (29) Responsibility Criteria that must be answered per the City's Responsible Contractor Ordinance. For each criterion provide a relevant response or attachments as required.

Answers to these criteria will not exclude any bidder from the bid process or ultimate award.

CRITERIA 1:	
COMPANY NAME:	BioTech Agronomics, Inc.
ADDRESS:	1651 Beulah Highway
CITY, STATE, ZIP:	Beulah, MI 49617
TELEPHONE:	231-882-7219
OFFICERS:	
President: Kevin Bonney	Email Address: kgbonney@biotechag.com
Vice President:	Email Address:
Secretary: Keith Bonney	Email Address:
Treasurer:	Email Address:
CRITERIA 2:	
How many years has your organization been in business under your present firm name? 23	
PARENT COMPANY NAME:	same
STREET ADDRESS:	
CITY, STATE, ZIP CODE:	
UNDER CURRENT MANAGEMENT SINCE (DATE):	2000

CRITERIA 3:

State and local licenses and license numbers held by your organization:

Biosolids Management Services in Michigan currently do not require State or Local licenses. N/A
Our MDOT # is 1188243

What are your formal training programs: a) apprentice/journeyman, b) other comparable formal training programs?

Other than general equipment and safety training - BioTech does not have apprentice or journeyman training programs.

CRITERIA 4:

Confirmation that all subcontractors, employees and other individuals working on the construction project will maintain current applicable licenses required by law for all licensed occupations and professions.

Drivers need to maintain proper drivers licenses.

CRITERIA 5:

Verification that the bidder is in compliance with all applicable state and federal laws and visa requirements regarding the hiring of non-US citizens, and disclosure of any work visas sought or obtained by the bidder, any of the bidder's subcontractors, or any of the bidder's employees or independent contractors, in order to perform any portion of the project.

BioTech Agronomics, Inc. currently does not have any non-US citizens employed.

CRITERIA 6 (ATTACHMENT REQUIRED)

Attach evidence of experience with construction techniques, trade standards, quality workmanship, project scheduling, cost control, management of projects of comparable size/complexity, and building codes by documenting the bidder's ability and capacity to perform the project. The bidder must identify those portions of the project it reasonably believes will be subcontracted and the names of the subcontractors.

CRITERIA 7 (ATTACHMENT REQUIRED)

Evidence of bonding capacity within the past twelve (12) months, that the applicant has financial resources to start up and follow through on the project(s) and to respond to damages in case of default as shown by written verification of bonding capacity equal to or exceeding the amount of the bidder's scope of work on the project. The written verification must be submitted by a licensed surety company rated "B+" (or better) in the current A.M. Best Guide and qualified to do business within the State of Michigan.

CRITERIA 8:

A list of all litigation and arbitrations currently pending and within the past five (5) years, including an explanation of each (parties, court/forum, legal claims, damages sought, and resolution).

NONE

CRITERIA 9:

Disclosure of any violations of state, federal or local laws or regulations, including OSHA or MIOSHA violations, state or federal prevailing wage laws, wage and hour laws, worker's compensation or unemployment compensation laws, rules or regulations, issued to or against the bidder within the past five years.

NONE

CRITERIA 10:

Disclosure of any debarment by any federal, state or local governmental unit and/or findings of non-responsibility or non-compliance with respect to any public or private construction project performed by the bidder.

NONE

CRITERIA 11:

Proof of insurance, including certificates of insurance, confirming existence and amount of coverage for liability, property damage, workers compensation, and any other insurances required by the proposed contract documents.

Name:

Lenz-Balder Insurance, Inc.

Type of Coverage:

See attached certificate

Telephone:

616-748-9440

Are you self-insured for Worker's Compensation Insurance? Yes No

CRITERIA 12 (ATTACHMENT REQUIRED):

A statement regarding the bidder's staffing capabilities and labor sources including subcontractors and a verification from the bidder that construction workers will not be misclassified as independent contractors in violation of state or federal law.

CRITERIA 13:

Verification of an existing Fitness for Duty Program (drugs and alcohol) of each employee working on the proposed jobsite.

Yes, we have a Fitness for Duty Program

No, we do not have a Fitness for Duty Program

Additional Information:

CRITERIA 14:

A warranty statement regarding labor, equipment and materials.

BioTech Agronomics, Inc. shall ensure that treated Class B biosolids will be safely transported to EGLE permitted land application site(s) and that the biosolids will be applied at agronomic rates per the City of Jackson's Residual Management Plan (RMP)

CRITERIA 15:

A statement affirming that the firm will pay all craft employees that it employs on the project the current wage rates and fringe benefits as required under applicable federal, state, or local wage laws.

BioTech Agronomics, Inc. does not employ or require any craft employees for this project.

CRITERIA 16:

A statement from the contractor or subcontractor acknowledging their obligation to comply with this Ordinance in each contract and subcontract.

BioTech Agronomics, Inc. will comply with the new ordinance.

CRITERIA 17:

A statement identifying what possible change orders could be necessary and what their approximate subsequent total costs would be.

The cost of fuel greatly affects our business. The cost of fuel has fluctuated sharply in the year 2022 and impacted our ability to maintain a profit on many projects. Depending on what the actual price of fuel might be would determine what our additional cost(s) would be.

CRITERIA 18:

Qualifications of management and supervisory personnel to be assigned by the bidder.

All managers and management of BioTech Agronomics, Inc. are qualified. The Owner and General Manager have over 55 years of experience.

CRITERIA 19 (ATTACHMENT REQUIRED):

References from individuals or entities the bidder has worked for within the last five (5) years including information regarding records of performance and job site cooperation.

CRITERIA 20:

Evidence of any quality assurance program used by the bidder and the results of any such program on the bidder's previous projects.

Our testing laboratory(s) have QC programs that are strictly adhered to and can be provided if needed.

CRITERIA 21:

Assurance that all construction work for this project must proceed economically, efficiently, continuously and without interruption.

BioTech Agronomics, Inc. strives to be efficient.

CRITERIA 22 (ATTACHMENT REQUIRED):

A list of projects completed within the past five (5) years of comparable size/complexity, including dates, clients, approximately dollar value, and size. Documentation from these previous projects including but not limited to all extra costs relating to the bidder's timeliness, performance, quality of work, extension requests, contractual fines and penalties imposed, liens filed, history of claims for extra work and any contract defaults with an explanation of the reason for the default and how the default was resolved.

CRITERIA 23:

The ratio of masters or journeypersons to apprentices proposed to be used on the construction project job site, if apprentices are to be used on the project.

Do you participate in the Registered Apprenticeship Programs that are registered with the United States Department of Labor Office of Apprenticeship or by a State Apprenticeship Agency recognized by the Office of Apprenticeship?

Yes

No

Additional Information:

This entire section appears to be non applicable to BioTech Agronomics, Inc.

(ATTACHMENT REQUIRED) Documentation of how the bidder assesses the skills and qualifications of any employees who do not have master or journeyperson certification or status, or are not participants in a Registered Apprenticeship Program.

CRITERIA 24 (ATTACHMENT REQUIRED)

Evidence of the bidder's worker's compensation Experience Modification Rating ("EMR"). Preference will be given to contractors and subcontractors who exhibit an EMR of 1.0 or less based on a three-year average.

CRITERIA 25:

All craft labor that will be employed by the firm for the project has completed at least the OSHA 10 hour training course of safety established by the U.S. Department of Labor, Occupational Safety & Health Administration.

Yes

No

CRITERIA 26 (ATTACHMENT REQUIRED):
Documentation of master or journey person certification or status for masters and journeypersons to be used on the project, and the source of such certification or status
CRITERIA 27:
A statement from the bidder as to what percentage of its workforce can be drawn significantly from area residents because a goal of the City is to utilize, in its construction activities, local residents as much as is economically feasible while retaining the high quality of construction required for its construction activities, consistent with applicable law. The City will consider in evaluating which bids best serve its interests, the extent to which responsible and qualified bidders are able to achieve this goal. BioTech Agronomics, Inc. generally employs truck drivers, equipment operators, general laborers, and mechanics. We currently have over 38 employees that live throughout the State of Michigan. We would welcome any qualified individuals from the City of Jackson area to join our team.
CRITERIA 28 (ATTACHMENT REQUIRED):
Evidence of Equal Employment Opportunity Programs for minorities, women, veterans, returning citizens, and small businesses.
CRITERIA 29:
Assurance that the bidder is an equal opportunity employer and does not discriminate on the basis of race, sex, pregnancy, age, religion, national origin, marital status, sexual orientation, gender identity of expression, height, weight, or disability. COMPANIES EQUAL EMPLOYMENT OPPORTUNITY STATEMENT: BioTech Agronomics, Inc is an Equal Employment Opportunity Employer.

BioTech Agronomics, Inc. / Don Popma, General Manager

Print Firm Name/Principal

Don Popma BioTech Agronomics, Inc

Signature/Principal
1/10/2023

Don Popma

Date

RESPONSIBLE CONTRACTOR BID EVALUATION CRITERIA

Once the City deems a contractor a responsible bidder, having used the process identified above, the City must consider the contractor's bid. The City must consider, at minimum, each of the evaluation criteria listed in this Section in determining the best bid. The City may require contractors or subcontractors to provide additional information by inclusion in bid documents. Additionally, the list set forth below in no way limits any additional criteria that the City may deem relevant for purposes of making a determination of the best bid.

Bid documents must require any contractor or subcontractor bidding on the project to submit written responses and other information and documentation regarding the listed criteria and any other criteria specified by the City through the bid documents. The City may request additional information or explanation from any contractor or subcontractor regarding any particular criteria. The bid documents must provide that the City retains the right in its discretion to reject any and all bids. All required contractor financial and privileged information must be kept from public disclosure unless otherwise required by law.

Submitted bids must break out labor costs from material and equipment costs.

For each separate bid package, the City in its discretion will weigh the information provided by the contractor or subcontractor regarding the evaluating criteria, as a whole, to determine the best bid. Except as otherwise required by law, no single criterion will necessarily be determinative in assessing which bid is the best bid. The Purchasing Department must weigh each of the criteria based on a distribution of percentage points on a 100-point scale. Additionally, The Purchasing Department shall provide space on the bid evaluation form for the prospective bidder to include additional information about themselves and/or their bid – this section would be optional for the prospective bidder to fill out. The criteria to be considered in bid evaluation on construction projects by the City shall be weighed categorically as follows, and shall include:

Price (25%)

1. A statement identifying what possible change orders could be necessary and what their approximate subsequent total costs would be.

Submitted Bid:	BioTech Agronomics, Inc.
Labor Costs:	Included in the unit rate(s)
Materials Costs:	Included in the unit rate(s)
Equipment Costs:	Included in the unit rates(s)
Possible Change Orders:	Fuel costs.

Corporate Accountability (25%)

1. Qualifications of management and supervisory personnel to be assigned by the bidder.
2. References from individuals or entities the bidder has worked for within the last five (5) years including information regarding records of performance and job site cooperation.
3. Evidence of any quality assurance program used by the bidder and the results of any such program on the bidder's previous projects.
4. Assurance that all construction work for this project must proceed economically, efficiently, continuously and without interruption.
5. A list of projects completed within the past five (5) years of comparable size/complexity, including dates, clients, approximate dollar value, and size. Documentation from these previous projects including but not limited to all extra costs relating to the bidder's timeliness, performance, quality of work, extension requests, contractual fines and penalties imposed, liens filed, history of claims for extra work and any contract defaults with an explanation of the reason for the default and how the default was resolved.

Workplace Safety (25%)

1. The ratio of masters or journeypersons to apprentices proposed to be used on the construction project job site, if apprentices are to be used on the project.
2. Evidence of the bidder's worker's compensation Experience Modification Rating ("EMR"). Preference will be given to contractors and subcontractors who exhibit an EMR of 1.0 or less based on a three-year average.
3. All craft labor that will be employed by the firm for the project has completed at least the OSHA 10 hour training course for safety established by the U.S. Department of Labor, Occupational Safety & Health Administration.
4. Documentation of master or journeyperson certification or status for masters and journeypersons to be used on the project, and the source of such certification or status.

Workforce Development (15%)

1. Documentation as to pay rates of employees and whether the bidder provides health insurance, pension or other retirement benefits, paid leave, or other benefits to its employees.
2. Documentation if the bidder participates in a Registered Apprenticeship Program that is registered with the United States Department of Labor Office of Apprenticeship or by a State Apprenticeship Agency recognized by the Office of Apprenticeship.
3. Documentation of how the bidder assesses the skills and qualifications of any employees who do not have master or journeyperson certification or status, or are not participants in a Registered Apprenticeship Program.

Social Equity (10%)

1. A statement from the bidder as to what percentage of its workforce can be drawn significantly from area residents because a goal of the City is to utilize, in its construction activities, local residents as much as is economically feasible while retaining the high quality of construction required for its construction activities, consistent with applicable law. The City will consider in evaluating which bids best serve its interests, the extent to which responsible and qualified bidders are able to achieve this goal.
2. Evidence of Equal Employment Opportunity Programs for minorities, women,

veterans, returning citizens, and small businesses.

3. Assurance that the bidder is an equal opportunity employer and does not discriminate on the basis of race, sex, pregnancy, age, religion, national origin, marital status, sexual orientation, gender identity or expression, height, weight, or disability.

BioTech Agronomics, Inc.

Residual Management Company

1651 US 31 • Beulah • MI • 49617 • P: 231-882-7219 • F: 231-882-9690

www.biotechag.com

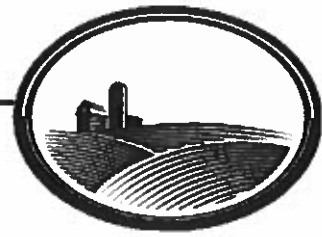

1/10/2023

**RESPONSIBLE CONTRACTOR
ORDINANCE**

ATTACHMENTS

BioTech Agronomics, Inc.

Residual Management Company

1651 US 31 • Beulah • MI • 49617 • P: 231-882-7219 • F: 231-882-9690
www.biotechag.com

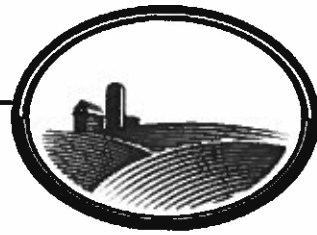

Criteria 6 - attachment

Company Overview:

BioTech Agronomics, Inc., is a Michigan based business incorporated in the State of Michigan. The business was started in the year 2000 by Mr. Kevin Bonney. Our company prides itself on our reputation for honesty, integrity, and professionalism throughout the biosolids industry.

BioTech Agronomics currently provides professional residuals management services for over 95 municipal and industrial wastewater plants within the State of Michigan. A few of our respected clients include the City of Battle Creek, Oakland County, and the City of Detroit.

Management Team:

Mr. Kevin Bonney: President and CEO

As President of BioTech Agronomics, Inc., Mr. Bonney began his independent successful enterprise in the biosolids management field in 2000. He has developed a staff of professionals with a clear focus on service and administration of BioTech's customer base and business development. The objective of our firm is to dedicate senior level management for oversight of all projects. Service to our clients is his major focus.

Mr. Bonney is also CEO of the corporation. Mr. Bonney will be directly involved in the on-going operations at your facility. With over twenty-five years of experience in environmental contracting he has an acute awareness of the resources required for each task. Mr. Bonney will ensure that those resources are available on your project.

Mr. Donald Popma: General Manager

Don has been in the Residuals Management Business for over 30 years and has experience and expertise with both municipal and industrial residuals. Don has been responsible for hundreds of projects throughout the Midwestern states with hands on experience in areas of the business such as permit compliance, land permitting, customer and public relations, sales, dewatering, and both liquid and cake land application beneficial reuse operations. Don has successfully completed courses at Davenport College and Grand Rapids Community College in Business Management and Inter-Personal Communication and Agronomy courses through Michigan State University. Don is a long-time member of the Michigan Water Environment Association (MWEA) and received the Residuals Management Professional of the Year award. He is responsible for all business development of

BioTech Agronomics, Inc.

Residual Management Company

1651 US 31 • Beulah • MI • 49617 • P: 231-882-7219 • F: 231-882-9690
www.biotechag.com

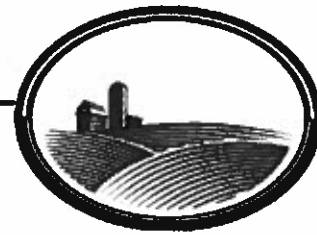

sales and the general oversight of day-to-day operations within the Company to direct responsibility of all matters of new and existing projects.

Mr. AJ Elliott: Director of Operations

AJ joined the firm in 2015, was appointed to Land Manager a few months later, and became the Director of Operations in 2018. AJ has over 12 years of business management experience, and grew up around the waste management industry. He has experience in all areas of the business such as land permitting, permit compliance, and customer and public relations with both liquid and cake application. AJ routinely meets and coordinates with WWTP staff to ensure that all details associated with the various projects are addressed. His responsibility to schedule equipment and personnel will ensure the necessary resources are available to fulfill the various project obligations. AJ is responsible for the day-to-day operations of all application crews and agronomy staff.

Mr. Russ Eberhart: Compliance Manager

Russ joined the firm in 2001 and was appointed Operations Manager in 2003. In 2014 Russ was appointed to be our Compliance Manager to maintain and ensure 100% compliance in all areas of the company. His extensive knowledge of the operations over his tenure with BioTech has made Russ an integral and valuable member of the management team. Russ is responsible for all EGLE reporting requirements for all projects.

Mrs. Jennifer Wightman: Office Manager

Jennifer joined the company in 2013 after working in the remediation and insurance industries. Jennifer earned her Bachelor's Degree in Business Administration, majoring in Accounting, from Western Governors University and has 20 years of Office Management experience. Jennifer is responsible for the daily operation of Accounts Receivable, Accounts Payable, Payroll, Insurance, Tax, Unemployment, and all financial issues, as well as direct support to the CEO and the rest of the management team. She and her husband spend most of their free time boating and camping near White Cloud Michigan.

BioTech Agronomics, Inc.

Residual Management Company

1651 US 31 • Beulah • MI • 49617 • P: 231-882-7219 • F: 231-882-9690
www.biotechag.com

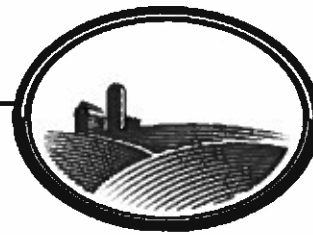

Mr. Matt Chrisinske: Land Manager

Matt joined BioTech in March of 2020 as a Land Manager. A graduate of Ferris State University, he has spent the last 10 years managing hotels and restaurants, before leaving to spend more time with his wife Katelyn and daughter Emmerson. Matt, along with his cousin, took over his family farm in 2012 due to the unexpected passing of his father. His family has been having biosolids applied on their farm for over 30 years. This uniquely qualifies him to speak to the benefits of biosolids and how the program can easily be integrated into most farm operations. Today the 1600-acre farm applies five to six million gallons across three to four hundred acres annually, all while practicing proper crop rotation, reduced fertilizer inputs, conservation practices like buffer strips and cover crops. When he is not working for BioTech, Matt manages the business, fertility and pesticide programs on his farm. He also enjoys spending time outdoors with his wife and daughter, be it in the garden, on the lake, or hunting.

Mr. Philip Loew: Land Manager

Phil joined BioTech in July 2022 as a Land Manager. A graduate of Michigan State University with a BS Degree and Western Michigan University with a MS Degree, he has spent the last 25 years involved with environmental clean-up, wastewater operations, and conducting safety training, as project manager and geologist. Phil also taught an Environmental Science class at NMC. Phil recently was a truck driver for the past two years.

Phil's understanding of wastewater and waste lagoon management, uniquely qualifies him to speak to the benefits of biosolids and how the program can easily be integrated into most farm operations.

Phil and his wife Laurie have raised three young men who are all three Eagle Scouts, and successful in their lives and careers. When he is not working for BioTech, Phil enjoys spending time outdoors riding his motorcycle, fishing, or hunting.

#7

Criteria 7 attachment

MERCHANTS BONDING COMPANY™

December 27, 2022

RE: Principal: BioTech Agronomics, Inc.
Current Bonding Limits: \$1,000,000 single, \$5,000,000 aggregate
Providing Surety Needs Since: 2011

We are pleased to write to you concerning the above principal. We would anticipate no problems providing the customary performance and payment bonds for their normal scope of work should they enter into a written contract.

The surety for this principal, Merchants Bonding Company is an AM Best rated "A VIII" company and is an admitted surety in all states. Merchants Bonding Company also appears on the U.S. Treasury list of approved companies.

Although this principal has our highest recommendation, execution of any final bonds would be subject to a review of the contract terms and conditions, including any requested bond forms, and also their current financial standing at the time of the request.

This letter is written for no consideration and is not a legally binding document or commitment to provide future bonds.

Please contact us with any concerns or if we can be of further service.

Jason Dettbarn, Attorney-in-Fact

ACKNOWLEDGMENT OF SURETY

State of Iowa)
County of Dallas)

On this 27th day of December, 2022, before me personally appeared Jason Dettbarn, of Merchants Bonding Company, who being sworn, stated that he/she is Attorney-In-Fact for the surety and that he/she signed this instrument for the surety.

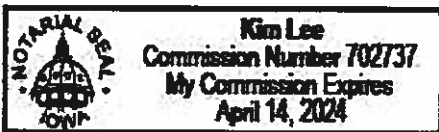

Kim Lee, Notary Public
My commission expires: April 14, 2024

street
6700 Westown Parkway
West Des Moines, IA 50266-7754

mailing
P.O. Box 14498
Des Moines, IA 50306-3498

toll free 800.678.8171
local 515.243.8171
fax 515.243.3854

email info@merchantsbonding.com
website merchantsbonding.com

**MERCHANTS
BONDING COMPANY**
POWER OF ATTORNEY

Know All Persons By These Presents, that MERCHANTS BONDING COMPANY (MUTUAL) and MERCHANTS NATIONAL BONDING, INC., both being corporations of the State of Iowa, d/b/a Merchants National Indemnity Company (in California only) (herein collectively called the "Companies") do hereby make, constitute and appoint, individually,

Jason Dettbarn

their true and lawful Attorney(s)-in-Fact, to sign its name as surety(ies) and to execute, seal and acknowledge any and all bonds, undertakings, contracts and other written instruments in the nature thereof, on behalf of the Companies in their business of guaranteeing the fidelity of persons, guaranteeing the performance of contracts and executing or guaranteeing bonds and undertakings required or permitted in any actions or proceedings allowed by law.

This Power-of-Attorney is granted and is signed and sealed by facsimile under and by authority of the following By-Laws adopted by the Board of Directors of Merchants Bonding Company (Mutual) on April 23, 2011 and amended August 14, 2015 and adopted by the Board of Directors of Merchants National Bonding, Inc., on October 16, 2015.

"The President, Secretary, Treasurer, or any Assistant Treasurer or any Assistant Secretary or any Vice President shall have power and authority to appoint Attorneys-in-Fact, and to authorize them to execute on behalf of the Company, and attach the seal of the Company thereto, bonds and undertakings, recognizances, contracts of indemnity and other writings obligatory in the nature thereof."

"The signature of any authorized officer and the seal of the Company may be affixed by facsimile or electronic transmission to any Power of Attorney or Certification thereof authorizing the execution and delivery of any bond, undertaking, recognizance, or other suretyship obligations of the Company, and such signature and seal when so used shall have the same force and effect as though manually fixed."

In connection with obligations in favor of the Florida Department of Transportation only, it is agreed that the power and authority hereby given to the Attorney-in-Fact includes any and all consents for the release of retained percentages and/or final estimates on engineering and construction contracts required by the State of Florida Department of Transportation. It is fully understood that consenting to the State of Florida Department of Transportation making payment of the final estimate to the Contractor and/or its assignee, shall not relieve this surety company of any of its obligations under its bond.

In connection with obligations in favor of the Kentucky Department of Highways only, it is agreed that the power and authority hereby given to the Attorney-in-Fact cannot be modified or revoked unless prior written personal notice of such intent has been given to the Commissioner-Department of Highways of the Commonwealth of Kentucky at least thirty (30) days prior to the modification or revocation.

In Witness Whereof, the Companies have caused this instrument to be signed and sealed this 27th day of December, 2022.



MERCHANTS BONDING COMPANY (MUTUAL)
MERCHANTS NATIONAL BONDING, INC.
d/b/a MERCHANTS NATIONAL INDEMNITY COMPANY

By *Larry Taylor*
President

STATE OF IOWA
COUNTY OF DALLAS ss.

On this 27th day of December, 2022, before me appeared Larry Taylor, to me personally known, who being by me duly sworn did say that he is President of MERCHANTS BONDING COMPANY (MUTUAL) and MERCHANTS NATIONAL BONDING, INC.; and that the seals affixed to the foregoing instrument are the Corporate Seals of the Companies; and that the said instrument was signed and sealed in behalf of the Companies by authority of their respective Boards of Directors.

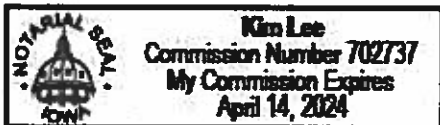

Kim Lee
Notary Public

(Expiration of notary's commission does not invalidate this instrument)

I, William Warner, Jr., Secretary of MERCHANTS BONDING COMPANY (MUTUAL) and MERCHANTS NATIONAL BONDING, INC., do hereby certify that the above and foregoing is a true and correct copy of the POWER-OF-ATTORNEY executed by said Companies, which is still in full force and effect and has not been amended or revoked.

In Witness Whereof, I have hereunto set my hand and affixed the seal of the Companies on this 27th day of December, 2022.



William Warner Jr.
Secretary

BioTech Agronomics, Inc.

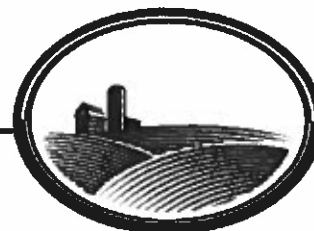

Residual Management Company

1651 US 31 • Beulah • MI • 49617 • P: 231-882-7219 • F: 231-882-9690

www.biotechag.com

1/10/2023

BioTech Agronomics, Inc. owns and operates a fleet of road tractors, tankers, field applicators, pumps, pump tractors, gravel trains and service trucks. We also maintain a repair facility located at 1651 Beulah Hwy., Beulah, MI.

We normally have 5-6 liquid applications crews working throughout the state 10 months of the year. We have plenty of equipment already operating and no additional capital expense is required for this project.

Criteria 19 - attachment
BioTech Agronomics, Inc.

Residual Management Company

1651 US 31 • Beulah • MI • 49617 • P: 231-882-7219 • F: 231-882-9690
www.biotechag.com

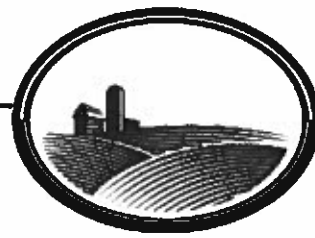

List of References

January 10, 2023

City of Reed City WWTP

Mr. Curt Brackenrich, Supt.

227 E. Lincoln Street

Reed City, MI 49677

(231) 832-5353

Liquid land application of 2,500,000 gallons of class B biosolids annually

Bay County WWTP

Mr. Allen Cardinal, Supt.

3933 Patterson Road

Bay City, MI 48706

(989) 684-3883

Land Application of 3,000,000 gallons of class B biosolids annually

City of Battle Creek WWTP

Mr. Rodney Clifton, Supt.

2000 W. River Road

Battle Creek, MI 49015

(269) 966-3513

Liquid land application of 14,000,000 gallons of class B biosolids annually

City of Big Rapids WWTP

Mr. Dave Cushway, Supt.

226 North Michigan Ave.

Big Rapids, MI 49307

(231) 796-8483

Land Application of 1,500,000 gallons of class B biosolids annually

City of Jackson WWTP

Mr. Trent Stockman, Supt.

2995 Lansing Ave

Jackson, MI 49202

(517) 768-6147

Land Application of 4,500,000 gallons of class B biosolids annually.

BioTech Agronomics, Inc.

Residual Management Company

1651 US 31 • Beulah • MI • 49617 • P: 231-882-7219 • F: 231-882-9690
www.biotechag.com

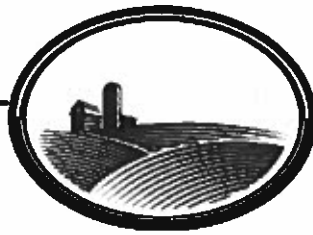

Criteria 22 - attachment

List of References

January 10, 2023

City of Reed City WWTP
Mr. Curt Brackenrich, Supt.
227 E. Lincoln Street
Reed City, MI 49677
(231) 832-5353

Liquid land application of 2,500,000 gallons of class B biosolids annually
Annual value as of 2022 is \$85,000 - Extensions approved. No contractual issues.

Bay County WWTP
Mr. Allen Cardinal, Supt.
3933 Patterson Road
Bay City, MI 48706
(989) 684-3883

Land Application of 3,000,000 gallons of class B biosolids annually
Annual value as of 2022 is \$135,000 - Extensions approved. No contractual issues.

City of Battle Creek WWTP
Mr. Rodney Clifton, Supt.
2000 W. River Road
Battle Creek, MI 49015
(269) 966-3513

Liquid land application of 14,000,000 gallons of class B biosolids annually
Annual value as of 2022 is \$700,000 - Extensions approved. No contractual issues.

City of Big Rapids WWTP
Mr. Dave Cushway, Supt.
226 North Michigan Ave.
Big Rapids, MI 49307
(231) 796-8483

Land Application of 1,500,000 gallons of class B biosolids annually
Annual value as of 2022 is \$72,000 - Extensions approved. No contractual issues.

City of Jackson WWTP
Mr. Trent Stockman, Supt.
2995 Lansing Ave
Jackson, MI 49202
(517) 768-6147

Land Application of 5,000,000 gallons of class B biosolids annually.
Annual value as of 2022 is \$185,000 - Extension approvals vary. No contractual issues.

Criteria 24. attachment



LENZ-BALDER
INSURANCE

December 27, 2022

Re: BioTech Agronomics, Inc.

To whom it may concern:

This letter confirms the experience modification factor for BioTech Agronomics, Inc. located in Beulah Michigan for the time period shown below:

12/11/2019 – 12/11/2020 is 1.00

12/11/2020 – 12/11/2021 is 0.99

12/11/2021 – 12/11/2022 is 0.99

12/11/2022 – 12/11/2023 is 0.99

Please do not hesitate to contact me if you have any questions.

Sincerely,

A handwritten signature in black ink, appearing to read 'Brad Balder', written in a cursive style.

Brad Balder
President



340 120th Avenue, Holland, MI 49424 P: 616-748-9440 F: 616-237-5915

WWW.LENZBALDERINS.COM

BioTech Agronomics, Inc.

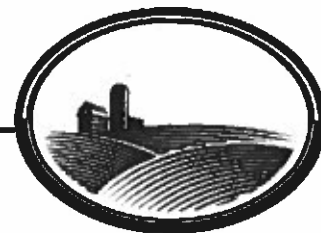

Residual Management Company

1651 US 31 • Beulah • MI • 49617 • P: 231-882-7219 • F: 231-882-9690

www.biotechag.com

Criteria 26 - Attachment

1/10/2023

BioTech Agronomics, Inc. does not have any master or journeypersons employed at this time. Therefore, no certifications are available to include with our bid submittal.

N/A

3 EMPLOYMENT POLICIES**3.1 Philosophy and Work Environment**

The personnel policies of BioTech Agronomics, Inc. are designed to help build a work environment that recognizes you as a valuable resource who is essential to our success. In turn, BioTech Agronomics, Inc. trusts that you will give your very best efforts and will work cooperatively with others as you perform your job. There is a strong partnership between you, your supervisor, and all other employees of BioTech Agronomics, Inc. in which the effectiveness and success of each person depends on the willing cooperation and trust of all the others.

To foster this environment, BioTech Agronomics, Inc. has three overall employee relations objectives. First, to help assure that you are treated with dignity and respect in your employment relationship with us; second, to recognize you as an individual; and third, to help you and all other employees of BioTech Agronomics, Inc. realize job satisfaction as part of a team that is dedicated to maintaining the highest quality products and services.

3.2 Equal Opportunity and Non-Discrimination

In keeping with its goals of individual recognition and treatment characterized by dignity and respect, BioTech Agronomics, Inc. is committed to providing equal employment opportunities to employees and to applicants for employment and will not discriminate on the basis of race, creed, color, religion, national origin, sex, age, disability, height, weight, veteran or marital status or any other reason prohibited by law in hiring, promotion, or any other aspect of your employment with us. As part of this policy, BioTech Agronomics, Inc. has a zero-tolerance policy on abusing the dignity of anyone through jokes, slurs, or other derogatory comments or statements that refer to ethnic origin, race, sex, religion, age, disability, height, weight, veteran or marital status or conduct of any objectionable nature. Any employee, supervisor, or other representative of BioTech Agronomics, Inc. who violates this policy will be subject, in the sole discretion of BioTech Agronomics, Inc. to prompt disciplinary action, up to and including discharge.

3.3 Employment of the Disabled

BioTech Agronomics, Inc. welcomes disabled applicants, including disabled veterans, and does not discriminate against people with disabilities. It is BioTech Agronomics, Inc.'s policy to employ and promote qualified disabled employees, using the same criteria that are used in the employment of other employees. BioTech Agronomics, Inc. will also make reasonable accommodations for the limitations of qualified disabled individuals, provided it would not result in undue hardship to BioTech Agronomics, Inc.

Disabled employees who require accommodations should contact the President or his designated representative.

AIA Document A310™ – 2010

Bid Bond

CONTRACTOR:

(Name, legal status and address)

Michigan AgriBusiness Solutions, LLC

9209 Heatherfield Lane

Saginaw, MI 48609

SURETY:

(Name, legal status and principal place of business)

United States Fire Insurance Company

305 Madison Avenue

Morristown, NJ 07960

This document has important legal consequences. Consultation with an attorney is encouraged with respect to its completion or modification.

Any singular reference to Contractor, Surety, Owner or other party shall be considered plural where applicable.

OWNER:

(Name, legal status and address)

City of Jackson

BOND AMOUNT: Five Percent of Bid (5% of Bid)

PROJECT: City of Jackson Michigan- Hauling and Land Application of Wastewater Biosolids for the City of Jackson
(Name, location or address, and Project number, if any)

The Contractor and Surety are bound to the Owner in the amount set forth above, for the payment of which the Contractor and Surety bind themselves, their heirs, executors, administrators, successors and assigns, jointly and severally, as provided herein. The conditions of this Bond are such that if the Owner accepts the bid of the Contractor within the time specified in the bid documents, or within such time period as may be agreed to by the Owner and Contractor, and the Contractor either (1) enters into a contract with the Owner in accordance with the terms of such bid, and gives such bond or bonds as may be specified in the bidding or Contract Documents, with a surety admitted in the jurisdiction of the Project and otherwise acceptable to the Owner, for the faithful performance of such Contract and for the prompt payment of labor and material furnished in the prosecution thereof; or (2) pays to the Owner the difference, not to exceed the amount of this Bond, between the amount specified in said bid and such larger amount for which the Owner may in good faith contract with another party to perform the work covered by said bid, then this obligation shall be null and void, otherwise to remain in full force and effect. The Surety hereby waives any notice of an agreement between the Owner and Contractor to extend the time in which the Owner may accept the bid. Waiver of notice by the Surety shall not apply to any extension exceeding sixty (60) days in the aggregate beyond the time for acceptance of bids specified in the bid documents, and the Owner and Contractor shall obtain the Surety's consent for an extension beyond sixty (60) days.

If this Bond is issued in connection with a subcontractor's bid to a Contractor, the term Contractor in this Bond shall be deemed to be Subcontractor and the term Owner shall be deemed to be Contractor.

When this Bond has been furnished to comply with a statutory or other legal requirement in the location of the Project, any provision in this Bond conflicting with said statutory or legal requirement shall be deemed deleted herefrom and provisions conforming to such statutory or other legal requirement shall be deemed incorporated herein. When so furnished, the intent is that this Bond shall be construed as a statutory bond and not as a common law bond.

Signed and sealed this 10th day of January, 2023

(Witness)

(Witness)

Kim Bennett

Michigan AgriBusiness Solutions, LLC

(Principal)

(Seal)

(Title)

United States Fire Insurance Company

(Surety)

(Seal)

(Title)

Ian Foster

, Attorney-in-Fact

Initial AIA Document A310™— 2010. Copyright ©1963, 1970 and 2010 by The American Institute of Architects. All rights reserved. WARNING: This AIA

Document is protected by U.S. Copyright Law and International Treaties. Unauthorized reproduction or distribution of this AIA Document, or any portion of it, may result in severe civil and criminal penalties, and will be prosecuted to the maximum extent possible under the law. Purchasers are permitted to reproduce ten (10) copies of this document when completed. To report copyright violations of AIA Contract Documents, e-mail The American Institute of Architects' legal counsel, copyright@aia.org.

061110

POWER OF ATTORNEY
UNITED STATES FIRE INSURANCE COMPANY
PRINCIPAL OFFICE - MORRISTOWN, NEW JERSEY

0112922

KNOW ALL MEN BY THESE PRESENTS: That United States Fire Insurance Company, a corporation duly organized and existing under the laws of the state of Delaware, has made, constituted and appointed, and does hereby make, constitute and appoint:

John Foster, Dan Cusenza, James Stear, Heather Buonodono, Ian Foster

each, its true and lawful Attorney(s)-In-Fact, with full power and authority hereby conferred in its name, place and stead, to execute, acknowledge and deliver Any and all bonds and undertakings of surety and other documents that the ordinary course of surety business may require, and to bind United States Fire Insurance Company thereby as fully and to the same extent as if such bonds or undertakings had been duly executed and acknowledged by the regularly elected officers of United States Fire Insurance Company at its principal office, in amounts or penalties not exceeding: Seven Million, Five Hundred Thousand Dollars (\$7,500,000).

This Power of Attorney limits the act of those named therein to the bonds and undertakings specifically named therein, and they have no authority to bind United States Fire Insurance Company except in the manner and to the extent therein stated.

This Power of Attorney revokes all previous Powers of Attorney issued on behalf of the Attorneys-In-Fact named above and expires on January 31, 2023.

This Power of Attorney is granted pursuant to Article IV of the By-Laws of United States Fire Insurance Company as now in full force and effect, and consistent with Article III thereof, which Articles provide, in pertinent part:

Article IV, Execution of Instruments - Except as the Board of Directors may authorize by resolution, the Chairman of the Board, President, any Vice-President, any Assistant Vice President, the Secretary, or any Assistant Secretary shall have power on behalf of the Corporation:

- (a) to execute, affix the corporate seal manually or by facsimile to, acknowledge, verify and deliver any contracts, obligations, instruments and documents whatsoever in connection with its business including, without limiting the foregoing, any bonds, guarantees, undertakings, recognizances, powers of attorney or revocations of any powers of attorney, stipulations, policies of insurance, deeds, leases, mortgages, releases, satisfactions and agency agreements;
- (b) to appoint, in writing, one or more persons for any or all of the purposes mentioned in the preceding paragraph (a), including affixing the seal of the Corporation.

Article III, Officers, Section 3.11, Facsimile Signatures. The signature of any officer authorized by the Corporation to sign any bonds, guarantees, undertakings, recognizances, stipulations, powers of attorney or revocations of any powers of attorney and policies of insurance issued by the Corporation may be printed, facsimile, lithographed or otherwise produced. In addition, if and as authorized by the Board of Directors, dividend warrants or checks, or other numerous instruments similar to one another in form, may be signed by the facsimile signature or signatures, lithographed or otherwise produced, of such officer or officers of the Corporation as from time to time may be authorized to sign such instruments on behalf of the Corporation. The Corporation may continue to use for the purposes herein stated the facsimile signature of any person or persons who shall have been such officer or officers of the Corporation, notwithstanding the fact that he may have ceased to be such at the time when such instruments shall be issued.

IN WITNESS WHEREOF, United States Fire Insurance Company has caused these presents to be signed and attested by its appropriate officer and its corporate seal hereunto affixed this 28th day of September, 2021.

UNITED STATES FIRE INSURANCE COMPANY

Matthew E. Lubin, President

State of New Jersey }
County of Morris }

On this 28th day of September, 2021, before me, a Notary public of the State of New Jersey, came the above named officer of United States Fire Insurance Company, to me personally known to be the individual and officer described herein, and acknowledged that he executed the foregoing instrument and affixed the seal of United States Fire Insurance Company thereto by the authority of his office.



Melissa H. D'Alessio (Notary Public)

I, the undersigned officer of United States Fire Insurance Company, a Delaware corporation, do hereby certify that the original Power of Attorney of which the foregoing is a full, true and correct copy is still in force and effect and has not been revoked.

IN WITNESS WHEREOF, I have hereunto set my hand and affixed the corporate seal of United States Fire Insurance Company on the 10th day of January 20 23

UNITED STATES FIRE INSURANCE COMPANY

Alfred N. Wright, Senior Vice President

CHECKLIST FOR BID SUBMITTAL

X BID BOND – If a bid bond is required, please submit your bid bond with your bid documents

X PROPOSAL SHEETS – Please fill out and have notarized your proposal sheets

X SAMS.GOV - Please register with SAM.GOV to be eligible to work on federally funded projects. Registration is free.

<https://sam.gov/content/entity-registration>

Please provide your sams.gov Unique Identity Number: CBCPMW3TLBT3
if you have received it.

PROPOSAL

TO: City Manager
c/o Purchasing Agent
City of Jackson, Michigan

Date: 1/4/2023

In compliance with your invitation for bids dated November 29, 2022 to perform
**HAULING AND LAND APPLICATION OF WASTEWATER BIOSOLIDS FOR
THE CITY OF JACKSON**

in the City of Jackson, the undersigned, a(n)

1. individual, resident of Saginaw, Michigan
doing business as Michigan AgriBusiness Solutions, LLC
at 3050 Freeway Lane, Saginaw, MI 48601
2. partnership, consisting of _____
and _____
under the firm name of _____
3. corporation by the name of _____
organized and existing under the laws of the State of _____
with offices at _____
(strike inapplicable clauses)

hereby proposes to perform said work, strictly as specified in the bid documents at the prices set forth on the attached schedule of bid prices, upon receipt of written notice of acceptance of this bid within ninety (90) calendar days after opening of the bids at the time stated in said Invitation; to execute a properly completed contract in the form provided with the bid documents in accordance with this bid; to give bond with good and sufficient surety or sureties, satisfactory to the City Attorney of Jackson, for the faithful performance of said contract, for payment of labor and materials, and, if required, for maintenance of work; and to give such bond within ten (10) days after notice of award.

FEDERAL ID# 61-1816212

(Corporate Seal, if applicable) Name of Bidder: Michigan AgriBusiness Solutions
Signed By: James Jurgens 
Its: President / Member

N
1-4-23

BID SHEET

DATE:

PROPOSAL FOR: HAULING AND LAND APPLICATION OF WASTEWATER BIOSOLIDS FOR THE CITY OF JACKSON

TO: The Mayor and the City Council
City of Jackson, Michigan

Ladies and Gentlemen:

The Undersigned has examined the plans, specifications, and the location of the above described work, and is fully informed as to the conditions relating to its performance, and understands the quantities shown in the estimate and on the plans are accurate to the best belief and knowledge of the Engineer, but are not guaranteed.

The undersigned hereby proposes to furnish all equipment, materials, supplies, labor, and services necessary to commence and complete the project as described in the Contract Documents; and in strict conformity with the requirements of the Specifications and such other special provisions and supplemental specifications as may be a part of this proposal for the above described project at the following unit prices all labor, equipment and materials necessary for completion of the work, but not specifically listed as a pay item, will be deemed to be included in one or more of the pay items listed in the bid sheet.

Bidder has examined and carefully studied the Bidding Documents, other related data identified in the Bidding Documents, and the following Addenda, receipt of which is hereby acknowledged (list addenda by Addendum Number and Date):

Addendum No.	Date
_____	_____
_____	_____
_____	_____

SCHEDULE OF BID PRICES
NOTE: UNIT PRICES MUST BE LISTED AND SHALL GOVERN.

ITEM NO	DESCRIPTION	TOTAL COST
1	Cost per gallon to pump haul and land apply liquid biosolids	\$0.041
2	Cost per cubic yard to load, haul and land apply dry biosolids	\$29.00
3	ALTERNATE PRICE: Cost per cubic yard to haul and land apply dry biosolids with City providing loader and operator.	\$25.50

W
1-4-23

Submitted Bid:	\$0.041 ppg
Labor Costs:	Included
Materials Costs:	No material costs
Equipment Costs:	Included
Possible Change Orders:	N/A

Bidder's Name:	Michigan AgriBusiness Solutions, LLC
Address:	3050 Freeway Lane
City, State, Zip:	Saginaw, MI 48601
Telephone:	989-399-0800
Fax:	989-399-0811

Email Address:	jim@michagbusiness.net
Federal ID Number:	61-1816212
Bid Signed By:	James C Jurgens  Print or Type
Title:	President / Member

1. I am the person described in and who executed the foregoing bid and that the several matters stated are in all respects true.
2. That I am an employee of the firm or company described in and I am authorized to submit said bid.

By James Jurgens  its President / Member

CONTRACT COMPLIANCE

DATE: November 29, 2022
TO: All Bidders
FROM: City of Jackson
SUBJECT: CONTRACT COMPLIANCE

The Commission of the City of Jackson, on 12/19/72, passed a resolution committing the City to a policy and procedure regarding compliance to affirmative hiring practices by contracting agencies doing business with the City of Jackson, effective 12/20/72.

The purpose of the policy and procedure is to ensure that all citizens of our community have the opportunity for the equality of treatment in service and employment.

The City requests that all bidders who will be doing business with the City in the amount of \$5,000 or more during any fiscal year, shall comply with the provisions of the Contract Compliance Policy.

Bidders will be required to show an Equal Employment Opportunity Certificate of Compliance or demonstrate compliance with standards for equal employment opportunity established by state and federal statute.

City Council of Jackson, Michigan

CONTRACT COMPLIANCE

CERTIFICATION

Michigan AgriBusiness Solutions certifies that he/she/it will not discriminate against any employee or applicant for employment with respect to hire, tenure, term, conditions, or privileges or employment because race, religion or national origin, color, age, sex, height, weight, marital status, sexual orientation, gender identity, and physical or mental handicap.

In connection with this commitment Michigan AgriBusiness Solutions understands that he/she/it name will be reviewed by the State of Michigan, Department of Civil Rights for determination of its status as an awardable Bidder.

The undersigned hereby agrees that he/she/it will abide by the terms of any agreements made with the City of Jackson in order to achieve awardable status.

Dated: 1/4/23

By: Michigan AgriBusiness Solutions
(Bidder's Name)

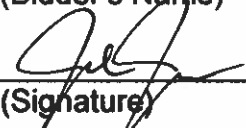
By: 
(Signature)

By: President / Member
(Title)

3050 Freeway Lane
Address

Saginaw
City

MI 48601
State and Zip

1-4-23

NON-DISCRIMINATION CLAUSE FOR ALL CITY OF JACKSON CONTRACTS

In connection with the performance of this contract, the contractor agrees as follows:

1. The contractor will not discriminate against any employee/employer for employment because of race, religion or national origin, color, age, sex, height, weight, marital status, sexual orientation, gender identity, and physical or mental handicap. The contractor will take affirmative action to ensure that minority applicants are employed, and that employees are treated during employment without regard to their race, religion, color, national origin, age, sex, height, weight, marital status or handicap. Such action shall include, but not be limited to, the following: layoff or termination, rates of pay or other forms of compensation, selection for training, upgrading or promotion, transfer or recruitment.
2. The contractor will, in all solicitations or advertisements for employees placed by or on behalf of the contractor, state that all qualified applicants will receive consideration for employment without regard to race, religion, color, national origin, age, sex, height, weight, marital status or handicap. As a disclaimer, the contractor may state in the advertisement that he/she is an equal opportunity employer.
3. The contractor will furnish and file compliance reports with the City of Jackson as requested. Such reports shall elicit information as to the practices, policies, program and employment statistics for the contractor and said contractor shall permit access to all books, records and accounts regarding employment practices by agents and representatives of the City duly charged with investigative duties to assure compliance with this clause.
4. Breach of the covenants herein may be regarded as a material breach of the contract, or purchasing agreement.
5. The contractor will include, or incorporate by reference, the provisions of paragraphs (1) through (4) in every subcontract or purchase order unless exempted by the rules, regulations or orders of the Michigan Civil Rights Commission and will provide in every subcontract or purchase order that said provisions will be binding upon each subcontractor or seller.

EQUAL EMPLOYMENT OPPORTUNITY CERTIFICATION

The undersigned understands and agrees that, as a Contractor for services, there shall be no discrimination against any employee or applicant for employment because of race, religion or national origin, color, age, sex, height, weight, marital status, sexual orientation, gender identity, and physical or mental handicap, including but no limited to employment, upgrading, demotion, or transfer; recruitment or recruitment advertising; layoff or termination; rates of pay or other forms of compensation and selection for training.

The Contractor further agrees to the following:

- (a) It will assist and actively cooperate with the City in obtaining compliance of any subcontractors with the equal opportunity rules, regulations, and relevant orders.
- (2) It will furnish the City such information as might be required for the supervision of its compliance program, and will otherwise assist the City in the discharge of its responsibility for ensuring compliance.
- (3) In the event that the Contractor fails or refuses to comply with the equal opportunity regulations, the City may cause to be canceled, terminated, or suspended in whole or in part the contractual arrangement between the City and the Contractor.

NAME OF BIDDER: Michigan AgriBusiness Solutions

ADDRESS: 3050 Freeway Lane
Saginaw, MI 48601

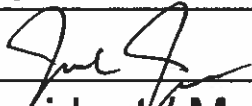
SIGNED BY: 

TITLE: President / Member

DATE: 1/4/23

W
1-4-23

CERTIFICATION OF NONSEGREGATED FACILITIES

The bidder certifies that he does not maintain or provide for his employees any segregated facilities and do not permit his employees to perform their services at any location, under his control, where segregated facilities are maintained. The bidder certifies further that he will not maintain or provide for his employees any segregated facilities at any of his establishments, and that he will not permit his employees to perform their services at any location under his control where segregated facilities are maintained. The bidder agrees that a breach of this certification will be a violation of the Equal Opportunity clause in any contract resulting from acceptance of this bid. As used in this certification, the term "segregated facilities" means any waiting rooms, work areas, restrooms and washrooms, restaurants and other eating areas, time clocks, locker rooms and other storage or dressing areas, parking lots, drinking fountains, recreation or entertainment areas, transportation, and housing facilities provided for employees which are segregated by explicit directive or are in fact segregated on the basis of race, color, religion, or national origin, because of habit, local custom, or otherwise. The bidder agrees that (except where he has obtained identical certification from proposed subcontractors for specific time periods) he will obtain identical certification from proposed subcontractors prior to the award of subcontracts exceeding \$10,000 which are not exempt from the provisions of the Equal Opportunity clause, and that he will retain such certifications in his files.

Dated: 1/4/23

By: Michigan AgriBusiness Solutions
(Bidder's Name)

By: 
(Signature)

By: President / Member
(Title)

3050 Freeway Lane
Address

Saginaw
City

MI 48601
State and Zip

W
1-4-23

NON-COLLUSION AFFIDAVIT OF PRIME BIDDER

STATE OF Ohio)
COUNTY OF Medina) ss

James Jurgens, being first duly sworn, deposed and says that:

1. He is President / Member of, Michigan AgriBusiness Solutions the Bidder that has submitted the attached bid;
2. He is fully informed respecting the preparation and contents of the attached bid and of all pertinent circumstances respected such bid;
3. Such bid is genuine and is not a collusive or sham bid;
4. Neither the said Bidder nor any of its officers, partners, owners, agents, representatives, employees or parties in interest, including this affiant, has in any way colluded, conspired, connived or agreed, directly or indirectly with any other Bidder, firm or person to submit a collusive or sham bid in connection with the contract for which the attached bid has been submitted or to refrain from bidding in connection with such contract, or has in any manner, directly or indirectly, sought by agreement or collusion or communication or conference with any other Bidder, firm or person to fix the price or prices in the attached bid or of any other Bidder, or to fix any overhead, profit or cost element of the bid price or the bid price of any other Bidder, or to secure through any collusion, conspiracy, connivance or unlawful agreement any advantage against the City of Jackson or any person interested in the proposed contract; and
5. The price or prices quoted in the attached bid are fair and proper and are not tainted by any collusion, conspiracy, connivance or unlawful agreement on the part of the Bidder or any of its agents, representatives, owners, employees, or parties in interest, including this affiant.

Dated: 1/4/23

By: Michigan AgriBusiness Solutions

(Company)

By: [Signature]

(Title)

Subscribed and sworn to before me, a Notary Public, this 4 day of January, 2023.

[Signature]

Notary Public, Medina county,

My commission expires: 03-16-2027



Madeline Smith
Notary Public, State of Ohio
My Commission Expires
March 16, 2027

**RIGHT TO KNOW
CONTRACTOR RELEASE FORM**

I, James Jurgens an authorized representative of Michigan AgriBusiness Solutions

am aware that as a requirement to perform work for the City of Jackson on a contractual basis, I must have provided my employees with the basic training requirements of the HAZARD COMMUNICATION STANDARD as prescribed by the Michigan Right to Know amendments to Act 154 of the Public Acts of 1974 (Act 80, Public Acts 1986), prior to starting any work for the City. While engaged in working for the City, I will continue to comply with Michigan Right to Know Law until completion of the contract.

I am aware that if I bring any hazardous chemical to the City's work place, I must have available the MSDS for these chemicals, in a place accessible to all employees in the work place. If necessary, due to the "special protection information" requirement stated on the MSDS for the chemicals, I will provide all employees with any special training, special protective clothing or equipment necessary to eliminate or lessen the possible exposure to the hazardous chemical or chemicals.

By execution of this Release, the contractor acknowledges that he and all subcontractors and suppliers, will comply with all requirements of the HAZARD COMMUNICATION STANDARD. Further, the contractor shall hold harmless from and indemnify the City against all claims, suits, actions, costs, counsel fees, expenses, damages, judgements or decrees, by reason of his failure, or the failure of any subcontractor, suppliers, or any person employed under said contractor to comply with the requirements of Act 154 of the Public Acts of 1974 as amended.

Dated 1/4/23

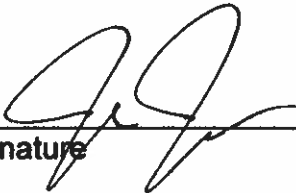
Signature _____



City of Jackson Ethics Disclosure Form Vendors and Contractors

Name James Jurgens	Company Michigan AgriBusiness Solutions
Telephone 989-399-0800	Email Address jim@michagbusiness.net

Contract or matter pending with the City:

Hauling and land application of wastewater biosolids for the City of Jackson

I, **James Jurgens**, being duly sworn, and pursuant to City of Jackson Ordinance No. 2015-18, I hereby disclose and swear to the following (check all that apply and provide details below):

- I, or my company's owners, members, major shareholders, or corporate officers, have a financial interest in a contract or matter pending before Jackson City Council.
- A relative¹ or immediate family member² of myself or my company's owners, members, major shareholders, or corporate officers has a financial interest in a contract or matter pending before a City office, department, board, or commission.
- I, or my company's owners, members, major shareholders, or corporate officers, have an interest in real or personal property that is subject to a decision by the City regarding the purchase, sale, lease, zoning, property improvements, NOORPR or FVA registration, a development agreement, or a special tax designation or abatement.

Property address: _____

Property interest: _____

- An immediate family member or relative of myself or my company's owners, members, major shareholders, or corporate officers, has a financial interest in real or personal property that is subject to a decision by the City regarding the purchase, sale, lease, zoning, property improvements, NOORPR or FVA registration, a development agreement, or a special tax designation or abatement.

¹ Relative means any spouse, domestic partner, great grandparents, step great grandparents, grandparents, step grandparents, sons, stepsons, daughters, step daughters, grandsons, step grandsons, granddaughters, step granddaughters, brothers, step brothers, sisters, step sisters, and in-laws of a Public Employee, the Mayor, an Elected Official, an Appointed Official, a member of a Board or Commission, a Contractor, or an Advisor of the City.

² Immediate family member means a Public Employee, the Mayor, an Elected Official, an Appointed Official, a member of a Board or Commission, a Contractor, or an Advisor's spouse, domestic partner, individual who lives in the Public Employee's household or an individual claimed by a Public Employee or a Public Employee's spouse as a dependent under the United States Internal Revenue Code at 26 USC 1, et seq.

Property address: _____

Property interest: _____

- An immediate family member or relative of myself or my company's owners, members, major shareholders, or corporate officers, is employed by the City or making an application for employment to the City.

Relative name: _____

City Department: _____

- I, or my company's owners, members, major shareholders, or corporate officers, have made campaign contributions in the last year to a candidate running for elective office with the City.

Name of Candidate: _____

Amount of Campaign Contribution: _____

The following entities and persons have a financial interest in the contract or matter identified above:

Additional information regarding any of the above:

- None of the above apply.

Dated:

Ohio

STATE OF MICHIGAN)

COUNTY OF JACKSON)

Medina

[Signature]
Signature

The foregoing instrument was acknowledged before me this 6 day of January, 2023
By James Jurgens

State of: Ohio

County of: Medina

The forgoing document was acknowledged before me 6 day of Jan., 2023

[Signature]

Your Name Here, Notary Public

My Commission Expires: 03-16-2027



Madlynne Smith
Notary Public, State of Ohio
My Commission Expires
March 16, 2027

Responsible Contractor Ordinance

Below are twenty-nine (29) Responsibility Criteria that must be answered per the City's Responsible Contractor Ordinance. For each criterion provide a relevant response or attachments as required.

Answers to these criteria will not exclude any bidder from the bid process or ultimate award.

CRITERIA 1:	
COMPANY NAME:	Michigan AgriBusiness Solutions
ADDRESS:	3050 Freeway Lane
CITY, STATE, ZIP:	Saginaw, MI 48601
TELEPHONE:	989-399-0800
OFFICERS:	
President: James Jurgens	Email Address: jim@michagbusiness.net
Vice President: Ken Wegener	Email Address: ken@michagbusiness.net
Secretary: Crystal Wegener	Email Address: crystal@michagbusiness.net
Treasurer:	Email Address:
CRITERIA 2:	
How many years has your organization been in business under your present firm name? 7	
PARENT COMPANY NAME:	N/A
STREET ADDRESS:	N/A
CITY, STATE, ZIP CODE:	N/A
UNDER CURRENT MANAGEMENT SINCE (DATE):	4/1/2017

CRITERIA 3:

State and local licenses and license numbers held by your organization:

N/A

What are your formal training programs: a) apprentice/journeyman, b) other comparable formal training programs?

Safety training protocols

CRITERIA 4:

Confirmation that all subcontractors, employees and other individuals working on the construction project will maintain current applicable licenses required by law for all licensed occupations and professions.

Agreed

CRITERIA 5:

Verification that the bidder is in compliance with all applicable state and federal laws and visa requirements regarding the hiring of non-US citizens, and disclosure of any work visas sought or obtained by the bidder, any of the bidder's subcontractors, or any of the bidder's employees or independent contractors, in order to perform any portion of the project.

The company is compliant

CRITERIA 6 (ATTACHMENT REQUIRED)

N/A

Attach evidence of experience with construction techniques, trade standards, quality workmanship, project scheduling, cost control, management of projects of comparable size/complexity, and building codes by documenting the bidder's ability and capacity to perform the project. The bidder must identify those portions of the project it reasonably believes will be subcontracted and the names of the subcontractors.

CRITERIA 7 (ATTACHMENT REQUIRED)

See Attached

Evidence of bonding capacity within the past twelve (12) months, that the applicant has financial resources to start up and follow through on the project(s) and to respond to damages in case of default as shown by written verification of bonding capacity equal to or exceeding the amount of the bidder's scope of work on the project. The written verification must be submitted by a licensed surety company rated "B+" (or better) in the current A.M. Best Guide and qualified to do business within the State of Michigan.

CRITERIA 8:

A list of all litigation and arbitrations currently pending and within the past five (5) years, including an explanation of each (parties, court/forum, legal claims, damages sought, and resolution).

NONE

CRITERIA 9:

Disclosure of any violations of state, federal or local laws or regulations, including OSHA or MIOSHA violations, state or federal prevailing wage laws, wage and hour laws, worker's compensation or unemployment compensation laws, rules or regulations, issued to or against the bidder within the past five years.

NONE

CRITERIA 10:

Disclosure of any debarment by any federal, state or local governmental unit and/or findings of non-responsibility or non-compliance with respect to any public or private construction project performed by the bidder.

NONE

CRITERIA 11:

Proof of insurance, including certificates of insurance, confirming existence and amount of coverage for liability, property damage, workers compensation, and any other insurances required by the proposed contract documents.

Name:	Mower-Ester Accident Fund et al
Type of Coverage:	All
Telephone:	517-371-2300
Are you self-insured for Worker's Compensation Insurance? Yes <input type="checkbox"/> No <input checked="" type="checkbox"/>	

CRITERIA 12 (ATTACHMENT REQUIRED): N/A

A statement regarding the bidder's staffing capabilities and labor sources including subcontractors and a verification from the bidder that construction workers will not be misclassified as independent contractors in violation of state or federal law.

CRITERIA 13:

Verification of an existing Fitness for Duty Program (drugs and alcohol) of each employee working on the proposed jobsite.

Yes, we have a Fitness for Duty Program

No, we do not have a Fitness for Duty Program

Additional Information:

CRITERIA 14:

A warranty statement regarding labor, equipment and materials.

MAS has a full allotment of labor and equipment as well as the capabilities to perform this work for the City of Jackson.

CRITERIA 15:

A statement affirming that the firm will pay all craft employees that it employs on the project the current wage rates and fringe benefits as required under applicable federal, state, or local wage laws.

MAS confirms that all craft employees of employ on this project will be paid current wage rates and benefits as required by applicable federal, state, or local wage laws.

CRITERIA 16:

A statement from the contractor or subcontractor acknowledging their obligation to comply with this Ordinance in each contract and subcontract.

MAS confirms the obligation to comply with this Ordinance of the contract and subcontract.

CRITERIA 17:

A statement identifying what possible change orders could be necessary and what their approximate subsequent total costs would be.

N/A

CRITERIA 18:

Qualifications of management and supervisory personnel to be assigned by the bidder.

Our company has been in business for 7 years. Our staff has over 100 years of experience in biosolid management and liquid land application.

CRITERIA 19 (ATTACHMENT REQUIRED): *Attached*

References from individuals or entities the bidder has worked for within the last five (5) years including information regarding records of performance and job site cooperation.

CRITERIA 20:

Evidence of any quality assurance program used by the bidder and the results of any such program on the bidder's previous projects.

N/A

CRITERIA 21:

Assurance that all construction work for this project must proceed economically, efficiently, continuously and without interruption.

MAS assures that all work on this project will proceed economically, efficiently, continuously and without interruption.

CRITERIA 22 (ATTACHMENT REQUIRED): *See Attached*

A list of projects completed within the past five (5) years of comparable size/complexity, including dates, clients, approximately dollar value, and size. Documentation from these previous projects including but not limited to all extra costs relating to the bidder's timeliness, performance, quality of work, extension requests, contractual fines and penalties imposed, liens filed, history of claims for extra work and any contract defaults with an explanation of the reason for the default and how the default was resolved.

CRITERIA 23:

The ratio of masters or journeypersons to apprentices proposed to be used on the construction project job site, if apprentices are to be used on the project.

Non-construction

Do you participate in the Registered Apprenticeship Programs that are registered with the United States Department of Labor Office of Apprenticeship or by a State Apprenticeship Agency recognized by the Office of Apprenticeship?

Yes

No

Additional Information:

(ATTACHMENT REQUIRED) Documentation of how the bidder assesses the skills and qualifications of any employees who do not have master or journeyperson certification or status, or are not participants in a Registered Apprenticeship Program.

CRITERIA 24 (ATTACHMENT REQUIRED) *See Attached*

Evidence of the bidder's worker's compensation Experience Modification Rating ("EMR"). Preference will be given to contractors and subcontractors who exhibit an EMR of 1.0 or less based on a three-year average.

CRITERIA 25:

All craft labor that will be employed by the firm for the project has completed at least the OSHA 10 hour training course of safety established by the U.S. Department of Labor, Occupational Safety & Health Administration.

Yes

No

CRITERIA 26 (ATTACHMENT REQUIRED): N/A

Documentation of master or journeyman certification or status for masters and journeymen to be used on the project, and the source of such certification or status

CRITERIA 27:

A statement from the bidder as to what percentage of its workforce can be drawn significantly from area residents because a goal of the City is to utilize, in its construction activities, local residents as much as is economically feasible while retaining the high quality of construction required for its construction activities, consistent with applicable law. The City will consider in evaluating which bids best serve its interests, the extent to which responsible and qualified bidders are able to achieve this goal.

It is anticipated that 30% of our workforce may come from the City of Jackson area.

CRITERIA 28 (ATTACHMENT REQUIRED): N/A

Evidence of Equal Employment Opportunity Programs for minorities, women, veterans, returning citizens, and small businesses.

CRITERIA 29:

Assurance that the bidder is an equal opportunity employer and does not discriminate on the basis of race, sex, pregnancy, age, religion, national origin, marital status, sexual orientation, gender identity of expression, height, weight, or disability. **COMPANIES EQUAL EMPLOYMENT OPPORTUNITY STATEMENT:**

MAS operates as an equal opportunity employment company.

James Jurgens

Print Firm Name/Principal

Signature/Principal

1/4/23

Date

RESPONSIBLE CONTRACTOR BID EVALUATION CRITERIA

Once the City deems a contractor a responsible bidder, having used the process identified above, the City must consider the contractor's bid. The City must consider, at minimum, each of the evaluation criteria listed in this Section in determining the best bid. The City may require contractors or subcontractors to provide additional information by inclusion in bid documents. Additionally, the list set forth below in no way limits any additional criteria that the City may deem relevant for purposes of making a determination of the best bid.

Bid documents must require any contractor or subcontractor bidding on the project to submit written responses and other information and documentation regarding the listed criteria and any other criteria specified by the City through the bid documents. The City may request additional information or explanation from any contractor or subcontractor regarding any particular criteria. The bid documents must provide that the City retains the right in its discretion to reject any and all bids. All required contractor financial and privileged information must be kept from public disclosure unless otherwise required by law.

Submitted bids must break out labor costs from material and equipment costs.

For each separate bid package, the City in its discretion will weigh the information provided by the contractor or subcontractor regarding the evaluating criteria, as a whole, to determine the best bid. Except as otherwise required by law, no single criterion will necessarily be determinative in assessing which bid is the best bid. The Purchasing Department must weigh each of the criteria based on a distribution of percentage points on a 100-point scale. Additionally, The Purchasing Department shall provide space on the bid evaluation form for the prospective bidder to include additional information about themselves and/or their bid – this section would be optional for the prospective bidder to fill out. The criteria to be considered in bid evaluation on construction projects by the City shall be weighed categorically as follows, and shall include:

Price (25%)

1. A statement identifying what possible change orders could be necessary and what their approximate subsequent total costs would be.

Submitted Bid:	No change orders expected
Labor Costs:	No change orders expected
Materials Costs:	No change orders expected
Equipment Costs:	No change orders expected
Possible Change Orders:	No change orders expected

✓
1-4-23

Corporate Accountability (25%)

1. Qualifications of management and supervisory personnel to be assigned by the bidder.
2. References from individuals or entities the bidder has worked for within the last five (5) years including information regarding records of performance and job site cooperation.
3. Evidence of any quality assurance program used by the bidder and the results of any such program on the bidder's previous projects.
4. Assurance that all construction work for this project must proceed economically, efficiently, continuously and without interruption.
5. A list of projects completed within the past five (5) years of comparable size/complexity, including dates, clients, approximate dollar value, and size. Documentation from these previous projects including but not limited to all extra costs relating to the bidder's timeliness, performance, quality of work, extension requests, contractual fines and penalties imposed, liens filed, history of claims for extra work and any contract defaults with an explanation of the reason for the default and how the default was resolved.

Workplace Safety (25%)

1. The ratio of masters or journeypersons to apprentices proposed to be used on the construction project job site, if apprentices are to be used on the project.
2. Evidence of the bidder's worker's compensation Experience Modification Rating ("EMR"). Preference will be given to contractors and subcontractors who exhibit an EMR of 1.0 or less based on a three-year average.
3. All craft labor that will be employed by the firm for the project has completed at least the OSHA 10 hour training course for safety established by the U.S. Department of Labor, Occupational Safety & Health Administration.
4. Documentation of master or journeyperson certification or status for masters and journeypersons to be used on the project, and the source of such certification or status.

Workforce Development (15%)

1. Documentation as to pay rates of employees and whether the bidder provides health insurance, pension or other retirement benefits, paid leave, or other benefits to its employees.
2. Documentation if the bidder participates in a Registered Apprenticeship Program that is registered with the United States Department of Labor Office of Apprenticeship or by a State Apprenticeship Agency recognized by the Office of Apprenticeship.
3. Documentation of how the bidder assesses the skills and qualifications of any employees who do not have master or journeyperson certification or status, or are not participants in a Registered Apprenticeship Program.

Social Equity (10%)

1. A statement from the bidder as to what percentage of its workforce can be drawn significantly from area residents because a goal of the City is to utilize, in its construction activities, local residents as much as is economically feasible while retaining the high quality of construction required for its construction activities, consistent with applicable law. The City will consider in evaluating which bids best serve its interests, the extent to which responsible and qualified bidders are able to achieve this goal.
2. Evidence of Equal Employment Opportunity Programs for minorities, women,

veterans, returning citizens, and small businesses.

3. Assurance that the bidder is an equal opportunity employer and does not discriminate on the basis of race, sex, pregnancy, age, religion, national origin, marital status, sexual orientation, gender identity or expression, height, weight, or disability.



Michigan AgriBusiness Bid Response & Attachments

MAS Bid Responses

Company Introduction

Michigan AgriBusiness Solutions (herein known as "MAS") is a Michigan based partnership founded in 2017. Partners Jim Jurgens and Ken Wegener formed a business from the remains of the exit of Synagro Central, LLC from the Michigan market. MAS purchased over \$1m in equipment from their former company while starting operations on April 1, 2017. The company, in 2017 and 2018, has hauled and land applied over 300 million gallons of biosolids in Michigan. The company is headquartered at 3050 Freeway Lane, Saginaw, MI 48601.

Project Personnel

Jim Jurgens, President/Member

Mr. Jurgens is responsible for overall management of biosolids project operations throughout Michigan. This includes supervision of Operation Managers, the Tech Service Manager and Tech Service Specialists, the equipment maintenance, transportation, permit compliance and customer relations.

Mr. Jurgens started MAS in 2017 after 10 years as a General Manager in manufacturing and service businesses. He has a B.A. degree in Business Administration from Baldwin Wallace College in Cleveland, Ohio. He earned his MBA in 2016 from Keller Graduate School of Management. Lastly, he earned his Black Belt Six Sigma certification from Notre Dame in 2008.

Ken Wegener, General Manager

As General Manager, Mr. Wegener is responsible for the overall management of all Michigan projects throughout the state. His responsibilities include supervision of Assistant Operation Managers, equipment maintenance, transportation, and customer relations.

Mr. Wegener has 30 years of experience in the industry. He currently oversees 7 full-service liquid land application crews that cover the State of Michigan. His span of responsibility covers over 60 municipal and industrial clients who generate over 140 million gallons of annual biosolids.

Bill Goetsch Technical Services Specialist

As Technical Services Specialist, Mr. Goetsch is responsible for oversight of our technical services staff for the State of Michigan. Bill has worked with over 75 Michigan WWTP's relative to biosolids management throughout the state. He has worked in Technical Services since 2005. His experience includes Residuals Management Plan Permit writing, biosolids sampling and procedures, land base permitting and maintenance, fertility recommendations, reporting and monitoring, and regulatory liaison, among others.

Mr. Goetsch has a B.S. in Food Systems Economics and Management with an emphasis in Crops and Soil Science from Michigan State University. He is a member of the Michigan Water Environment Association. He participates on the Biosolids Committee.



Michigan AgriBusiness References

Project/Bid:

City of Jackson

Benton Harbor / St. Joseph Joint WWTP

Mr. Timothy Lynch
269 Anchors Way
St. Joseph, MI 49085
269-983-7719

City of Petoskey WWTP

Ms. Sherrie Elliott
101 East Lake Street
Petoskey, MI 49770
231-348-0368

City of Saginaw WWTP

Mr. Pat Frazee
2406 Veterans Memorial Parkway
Saginaw, MI 48603
989-759-1630

Genesee County, Michigan

Mr. Joseph Goergen
G-9290 Farrand Road
Montrose, MI 48457
810-232-7662

Saginaw Township WWTP

Lee Keysor
5790 W. Michigan Ave
Saginaw, MI 48609
989-791-9870

Lapeer WWTP

Mr. Mike Wurtz
1264 Industrial Drive
Lapeer, MI 48446
810-664-6887



Michigan AgriBusiness Bid Response & Attachments

MAS Similar Projects

<u>Project 1</u> 2022 (JUN-AUG) Angel Pichala	Michigan Sugar (989) 686-0164 ext. 358	100% complete on ~20m gallons
<u>Project 2</u> 2021 (MAY-AUG) Angel Pichala	Michigan Sugar (989) 686-0164 ext. 358	100% complete on ~22m gallons
<u>Project 3</u> 2022 (APR-NOV) Brian Baldwin	City of Saginaw 989-759-1630	90% complete on ~17m gallons
<u>Project 4</u> 2021 (APR-NOV) Brian Baldwin	City of Saginaw 989-759-1630	90% complete on ~17m gallons
<u>Project 5</u> 2022 (MAY-NOV) Keith Sanders	Ann Arbor 734-794-6450	90% complete on ~15.5m gallons
<u>Project 6</u> 2020 (MAY-NOV) Keith Sanders	Ann Arbor 734-794-6450	100% complete on ~15.5m gallons
<u>Project 7</u> 2017 (APR-NOV) Tim Lynch	Benton Harbor / St. Joseph 269-983-7719	100% complete on ~8m gallons
<u>Project 8</u> 2018 (APR-NOV) Tim Lynch	Benton Harbor / St. Joseph 269-983-7719	100% complete on ~8m gallons
<u>Project 9</u> 2017 (APR-NOV) Joe Goergen	Genesee County 810-232-7662	100% complete on ~28m gallons
<u>Project 10</u> 2018 (APR-NOV) Joe Goergen	Genesee County 810-232-7662	100% complete on ~28m gallons

Year 2020

OSHA's Form 300A (Rev. 01/2004) Summary of Work-Related Injuries and Illnesses

All establishments covered by Part 1904 must complete this Summary page, even if no injuries or illnesses occurred during the year. Remember to review the Log to verify that the entries are complete. Using the Log, count the individual entries you made for each category. Then write the totals below, making sure you've added the entries from every page of the log. If you had no cases write "0."

Employees former employees, and their representatives have the right to review the OSHA Form 300 in its entirety. They also have limited access to the OSHA Form 301 or its equivalent. See 29 CFR 1904.35. In OSHA's Recordkeeping rule, for further details on the access provisions for these forms.

Number of Cases			
Total number of deaths	Total number of cases with days away from work	Total number of cases with job transfer or restriction	Total number of other recordable cases
(G) 0	(H) 0	(I) 0	(J) 0

Number of Days	
Total number of days away from work	Total number of days of job transfer or restriction
(K) 0	(L) 0

Injury and Illness Types			
Total number of ... (M)	(1) Injury	(4) Poisoning	(5) Hearing Loss
(2) Skin Disorder	0	0	0
(3) Respiratory Condition	0	(6) All Other Illnesses	0

Post this Summary page from February 1 to April 30 of the year following the year covered by the form

Public reporting burden for the collection of information is estimated to average 56 minutes per response, including time to review the instruction, search and gather the data needed, and complete and review the collection of information. Persons are not required to respond to the collection of information unless it displays a currently valid OMB control number. If you have any comments about these estimates or any aspect of the data collection, contact: US Department of Labor, OSHA Office of Statistics, Room N-394, 200 Constitution Ave, NW, Washington, DC 20210. Do not send the completed forms to this office.

Establishment Information	
Your establishment name	<u>Michigan AgriBusiness Solutions, LLC</u>
Street	<u>3050 Freeway Lane</u>
City	<u>Baginew</u> State <u>Michigan</u> Zip <u>48801</u>
Industry description (e.g., Manufacture of motor truck trailers)	<u>Heating and Land Application of Bleached Wood</u>
Standard Industrial Classification (SIC), if known (e.g., SIC 3715)	
OR North American Industrial Classification (NAICS), if known (e.g., 336212)	<u>2 2 1 3 2 0</u>
Employment Information	
Annual average number of employees	<u>20</u>
Total hours worked by all employees last year	<u>35211.25</u>
Sign here	
Knowingly falsifying this document may result in a fine.	
I certify that I have examined this document and that to the best of my knowledge the entries are true, accurate, and complete.	
<u>James G. Jurgens</u> Company executive	<u>President</u> Title
<u>888-398-0800</u> Phone	<u>2/15/21</u> Date

OSHA's Form 300A (Rev. 01/2004)

Summary of Work-Related Injuries and Illnesses

Year 2021

U.S. Department of Labor
Occupational Safety and Health Administration

Form approved OSHA no. 1218-078

All establishments covered by Part 1904 must complete this Summary page, even if no injuries or illnesses occurred during the year. Remember to review the Log to verify that the entries are complete. Using the Log, count the individual entries you made for each category. Then write the totals below, making sure you've added the entries from every page of the log. If you had no cases write "0".

Employees former employees, and their representatives have the right to review the OSHA Form 300 in its entirety. They also have limited access to the OSHA Form 301 or its equivalent. See 29 CFR 1904.35. In OSHA's Recordkeeping rule, for further details on the access provisions for these forms.

Number of Cases	Total number of cases with days away from work	Total number of cases with job transfer or restriction	Total number of other recordable cases
(G)	(H)	(I)	(J)
0	0	0	0

Number of Days	Total number of days of job transfer or restriction
(K)	(L)
0	0

Injury and Illness Types	Total number of...
(1) Injury (M)	0
(2) Skin Disorder	0
(3) Respiratory Condition	0
(4) Poisoning	0
(5) Hearing Loss	0
(6) All Other Illnesses	0

Post this Summary page from February 1 to April 30 of the year following the year covered by the form

Public reporting burden for this collection of information is estimated to average 58 minutes per response, including time to review the instruction, search and gather the data needed, and complete and review the collection of information. Persons are not required to respond to the collection of information unless it displays a currently valid OMB control number. If you have any comments about these estimates of burden or any aspects of this data collection, contact: US Department of Labor, OSHA Office of Statistics, Room N-3614, 200 Constitution Ave, NE, Washington, DC 20210. Do not send the completed forms to this office.

Establishment Information	
Your establishment name	<u>Michigan AgBusiness Solutions, LLC</u>
Street	<u>3050 Freeman Lane</u>
City	<u>Eastview</u>
State	<u>Michigan</u>
Zip	<u>48801</u>
Industry description (e.g. Manufacture of motor truck trailers)	<u>Hauling and Land Application of Biosolid Wastes</u>
Standard Industrial Classification (SIC), if known (e.g. SIC 3715)	<u>2 2 1 3 2 0</u>
North American Industrial Classification (NAICS), if known (e.g. 336212)	<u>2 2 1 3 2 0</u>
Employment Information	
Annual average number of employees	<u>20</u>
Total hours worked by all employees last year	<u>31817</u>
Sign here	
Knowingly falsifying this document may result in a fine.	
I certify that I have examined this document and that to the best of my knowledge the entries are true, accurate, and complete.	
<u>James C. Jurgens</u> Company executive	<u>President</u> Title
<u>888-398-0800</u> Phone	<u>2/12/22</u> Date



POLICY NUMBER: ENVPKGHI274112

COMMERCIAL GENERAL LIABILITY

THIS ENDORSEMENT CHANGES THE POLICY. PLEASE READ IT CAREFULLY.

**ADDITIONAL INSURED – OWNERS, LESSEES OR
CONTRACTORS – (FORM B)**

This endorsement modifies insurance provided under the following:

COMMERCIAL GENERAL LIABILITY COVERAGE PART.

SCHEDULE

Name of Person or Organization: City of Jackson

(If no entry appears above, information required to complete this endorsement will be shown in the Declarations as applicable to this endorsement.)

WHO IS AN INSURED (Section II) is amended to include as an insured the person or organization shown in the Schedule, but only with respect to liability arising out of "your work" for that insured by or for you.

MEMO TO: Jonathan Greene, City Manager
FROM: Michael Osborn, Director of Public Works
DATE: February 7, 2023
SUBJECT: Jackson Wastewater Treatment Plant Main Switchgear Project Change Order No 1

Recommendation:

Approve Project Change Order No 1, for the Jackson Wastewater Treatment Plant Main Switchgear Project to allow Expo Technologies LLC to perform the unforeseen but necessary wire replacement in the amount of \$16,839.00.

Your consideration and concurrence is appreciated.

Michael G. Osborn

DEPARTMENTAL REPORT

MEMO TO: Jonathan Greene, City Manager
FROM: Michael Osborn, Director of Public Works
DATE: February 7, 2023

RECOMMENDATION: Approve Project Change Order No 1, for the Jackson Wastewater Treatment Plant Main Switchgear Project to allow Expo Technologies LLC to perform the unforeseen but necessary wire replacement in the amount of \$16,839.00.

SUMMARY

The existing 300 kcmil cables are an adequate size given our current demand and dual service feed arrangement. However, if we're going to replace the cables, then we would recommend increasing it to 350 kcmil for flexibility in the future (e.g. if our demand increased in the future, the cables could be our limiting factor if not upsized.) Fishbeck and Consumers Energy both recommend that the conductors be replaced at this time, due to the age and reliability of the electrical service to the facility. If it is going to be done, now is the optimal time. Expo Technologies, LLC would be able to complete this work without any additional shutdowns to the Wastewater Treatment Plant.

BUDGETARY CONSIDERATIONS

The original approved Medium Voltage Switchgear Project was \$336,898.00. The funding of \$16,839.00 required for this change order will come out of the Wastewater equipment replacement fund 406-548-000-985.000. This brings the Total Project cost to \$353,791.00.

HISTORY, BACKGROUND and DISCUSSION

The Jackson Wastewater Treatment Plant receives two 8320Y/4800-volt, 3-phase electrical services from Consumers Energy. The two services are referred to as the Parnall and Wisner Circuits with the preferred circuit being Parnall. Both services are normally energized, but only one is used at a time. Power is distributed via a network of switchgear, unit substations, motor control centers, and distribution panel boards. Some equipment is double-ended, capable of being supplied by two separate power sources, while other equipment is single-ended, supplied by a single power source. A majority of the existing power distribution equipment is old and replacement parts may be difficult to find, especially new parts. In some cases, remanufactured parts may have to be used for repairs. This project shall include the replacement of the medium voltage main switchgear equipment and installation by the contractor.

The cable originally was the property of Consumers Energy. As part of this project, the city acquired some equipment and cables, because control of this equipment was in the best interest of the City of Jackson Wastewater Treatment Plant. It is most conducive to the plant staff to have control of this equipment as it is located within a city building. The wire being replaced runs from the Consumers Energy metering cabinet to the main switchgear at the Wastewater Treatment Plant. It was discovered in the field when Consumers Energy was replacing their metering cabinet that the cable was beyond its useful life, as it is over fifty years

old. In summary, it doesn't make sense to replace the metering cabinet and switchgear but leave the fifty year old cable in between.

POSITIONS

I recommend we approve Project Change Order No 1, for the Jackson Wastewater Treatment Plant Main Switchgear Project to allow Expo Technologies LLC to perform the unforeseen but necessary wire replacement in the amount of \$16,839.00.

**Change Order No. 1
To Contract for
Jackson WWTP Medium Voltage Main Switchgear Replacement
Wastewater Treatment Plant Jackson, Michigan**

Notice is hereby given that the following additional information and changes shall become a part of the Contract Documents of the above-named contract.

ORIGINAL CONTRACT AMOUNT	\$336,898.00
Change Order NO. 1	\$16,893.00
NEW CONTRACT AMOUNT AS SET BY Change Order NO. 1	\$353,791.00

REASON FOR AMENDMENT:

The existing 300 kcmil cables are an adequate size given our current demand and dual service feed arrangement (they could actually be smaller). But if we're going to replace the cables, then we would recommend increasing it to 350 kcmil for flexibility in the future (e.g. if our demand increased in the future, the cables could be our limiting factor if not upsized.) Fishbeck and Consumers both recommend that the conductors be replaced at this time, due to the age and reliability of the electrical service to the facility. If it is going to be done, now is the optimal time. Expo Technologies, LLC would be able to complete this work without any additional shutdowns to the Wastewater Treatment Plant.

Prepared by Michael Osborn
Director of Public Works

ACCEPTED BY:

Michael Odrobina, President
Expo Technologies, LLC

Date:

ACCEPTED BY:

Michael Osborn, Director of Public Works

Date:

ACCEPTED BY:

Jonathan Greene, City Manager

Date:

MEMO TO: Mayor and City Councilmembers
FROM: Jonathan Greene, City Manager
DATE: February 7, 2023
SUBJECT: **Changes to the Standard Lighting Contract for streetlights with Consumers Energy for the removal of one streetlight**

Recommendation:

Approve the Resolution for Changes to the Standard Lighting Contract for one streetlight removal with Consumers Energy and authorize the Mayor and City Clerk to execute the appropriate documents.

Attached is a report from Jon Dowling, City Engineer accompanied by a resolution, contract change authorization form, and plan sheet from Consumers Energy regarding the removal of one streetlight in the alley between Washington Avenue and Cortland Street, next to Parking Lot 9.

I recommend adoption of the resolution for the change to the Standard Lighting Contract for streetlights with Consumers Energy to allow for the removal of one streetlight, and authorization for associated form execution. Your consideration and concurrence is appreciated.

JG

DEPARTMENTAL REPORT

MEMO TO: Jonathan Greene, City Manager
FROM: Jon H. Dowling, P.E., City Engineer
DATE: February 7, 2023

RECOMMENDATION: **Approve the Resolution for Changes to the Standard Lighting Contract for one streetlight removal with Consumers Energy and authorize the Mayor and City Clerk to execute the appropriate documents.**

SUMMARY

The City has requested that Consumers Energy remove one (1) streetlight in the alley between Washington Avenue and Cortland Street next to Parking Lot 9. Attached is an Authorization for Change in Standard Lighting Contract form, a Resolution for City Council Adoption, and additional information from Consumers.

BUDGETARY CONSIDERATIONS

There is no charge for this removal.

HISTORY, BACKGROUND and DISCUSSION

The request for this removal streetlight was based on changing the parking lot lights in Parking Lot 9 to LED lights and powering them from the metered streetlight circuit. The old high pressure sodium Consumers Energy light is no longer necessary in the alley.

DISCUSSION OF THE ISSUE

The City of Jackson is responsible for the streetlight system within the City. The City contracts with Consumers Energy to provide streetlights on their wood utility poles within the City's neighborhoods.

POSITIONS

I request approval of the attached Resolution for Changes to the Standard Lighting Contract for one streetlight removal with Consumers Energy and authorization for the City Manager and City Clerk to execute the appropriate documents.

ATTACHMENTS



A CMS Energy Company

CEM Support Center

Consumers Energy, CEM Support Center, Lansing Service Center, Rm. 122, 530 W. Willow St., P.O. Box 30162 Lansing, MI 48909-7662

December 20, 2022

NOTIFICATION #:
1065096594

CITY OF JACKSON
161 W MICHIGAN AVE
JACKSON, MI 49201-1315

REFERENCE: WASHINGTON AND CORTLAND, JACKSON

Dear Valued Customer,

Thank you for contacting Consumers Energy for your energy needs. Please note the Notification Number above and include it on any correspondence you send. Please note the Account Number, located above the Account Name on your invoice, when submitting payment.

Enclosed for approval and signature is the original Authorization for Change and Resolution covering the replacement and/or installation of streetlight(s). You are responsible for the final restoration.

The estimated cost for your energy request is as follows:
Non Refundable Agreement for Installation of Electric Facilities:

Winter Construction Costs:	\$	-
Installation Charge:	\$	-
Additional Costs		
Total Estimated Cost:	\$	-
Less Prepayment Received:	\$	-
Total Estimated Cost Due:	\$	-

Please sign and return the original Authorization for Change and Resolution in the enclosed self-addressed envelope or email to: POBoxCEServiceRequest@cmsenergy.com. Payment in full is required before the installation can be scheduled for construction.

Please review all attached materials carefully and direct inquiries for your request to:
Tanya Gilroy at 616-251-0574 .

RESOLUTION

RESOLVED, that it is hereby deemed advisable to authorize Consumers Energy Company to make changes in the lighting service as provided in the Standard Lighting Contract between the Company and the City of JACKSON, dated 6/1/2010, in accordance with the Authorization for Change in Standard Lighting Contract dated _____,

heretofore submitted to and considered by this commission council board; and

RESOLVED, further, that the _____ Clerk be and are authorized to execute such authorization for change on the behalf of the City.

STATE OF MICHIGAN
COUNTY OF JACKSON

I, _____, clerk of the City of JACKSON do hereby certify that the foregoing resolution was duly adopted by the

commission council board of said municipality, at the meeting held on _____.

Dated:

Municipal Customer Type: City



**AUTHORIZATION FOR CHANGE IN STANDARD LIGHTING
CONTRACT(COMPANY-OWNED) FORM 547**

Contract Number: 100000287787

Consumers Energy Company is authorized as of _____ by the City of JACKSON, to make changes, as listed below, in the lighting system(s) covered by the existing Standard Lighting Contract between the Company and the City of JACKSON, dated 6/1/2010.

Lighting Type: General Service Unmetered Lighting Rate GUL, Standard High Intensity Discharge

Except for the changes in the lighting system(s) as herein authorized, all provisions of the aforesaid Standard Lighting Contract dated 6/1/2010 shall remain in full force and effect.

Notification Number(s): 1065096594

Comments:

City of JACKSON

By: _____

(Signature)

(Printed)

Its: _____

(Title)

This Agreement may be executed and delivered in counterparts, including by a facsimile or an electronic transmission thereof, each of which shall be deemed an original. Any document generated by the parties with respect to this Agreement, including this Agreement, may be imaged and stored electronically and introduced as evidence in any proceeding as if original business records. Neither party will object to the admissibility of such images as evidence in any proceeding on account of having been stored electronically.

GENERAL SERVICE UNMETERED LIGHTING RATE GUL, STANDARD HIGH INTENSITY DISCHARGE

- (1) 250 watt HPS Cobrahead Cutoff to Remove at location 5;

LEAVE STEEL POLES
 AT LOC 2-4 REMOVE
 POLE TAGS. LEAVE
 WOODED POLE AT LOC
 5 REMOVE POLE TAG
 LEAVE SEC FROM LOC
 2-4 AND FROM 2 TO 5
 LEAVE LIGHTS AT LOC
 2,3,4 THOSE ARE CITY
 OWNED OURS HAVE BEEN
 REMOVED

CONTACT LAURA
 517-768-6065
 WHEN SCHEDULING
 THE WORK. THEY
 ASK FOR IT NOT
 TO BE DONE ON A
 THURSDAY OR FRIDAY

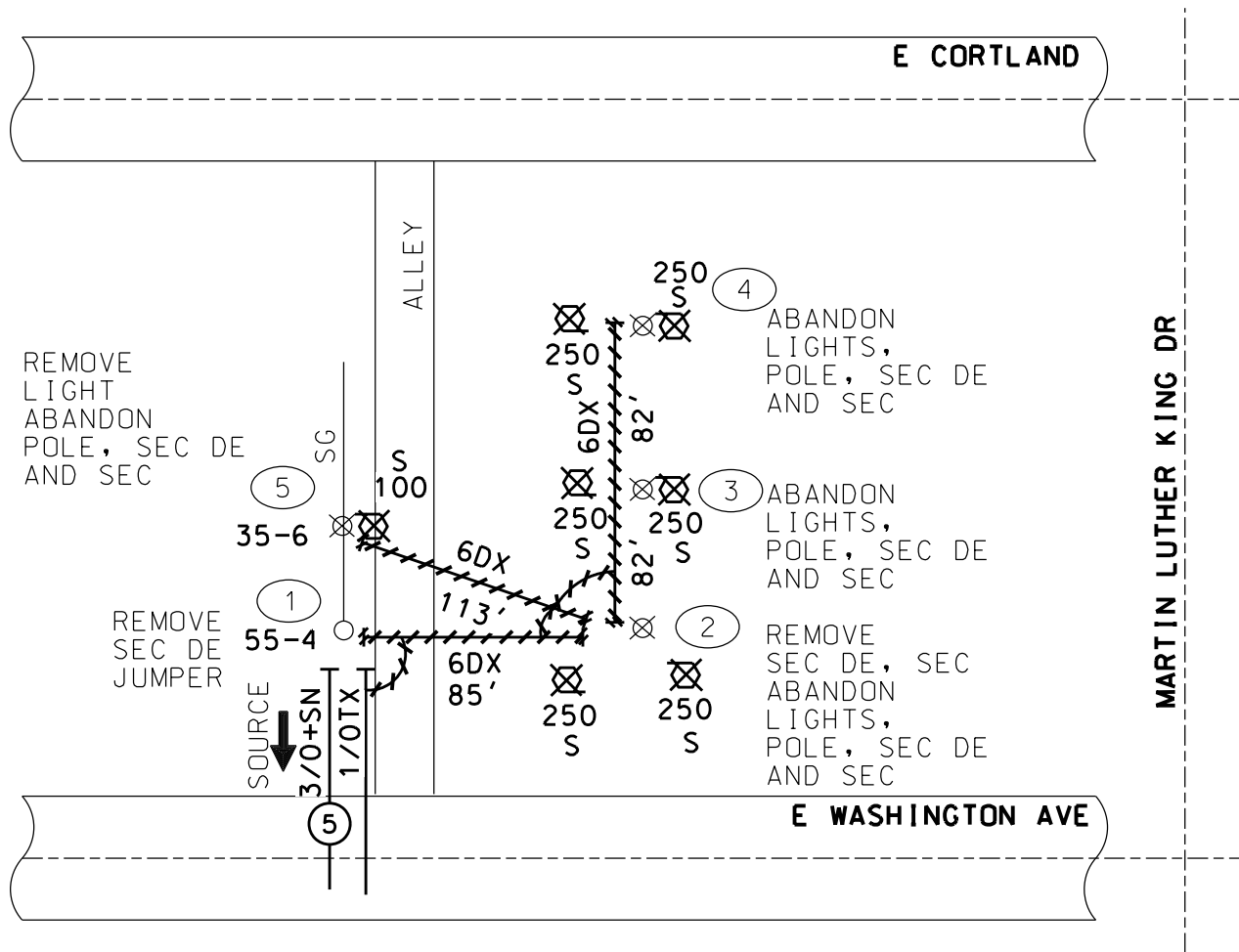

		METER NUMBER			METER ORDER NUMBER			CONSUMERS ENERGY CONTACTS				
		_____			_____			DEPARTMENT				
		READ			_____			NAME				
SUBSTATION		WD NO.		METER LOCATION			COORDINATOR			GABRIEL POLETTI	810-241-8179	
BRIDGE STREET		0319		---			DESIGNER			EDDIE HAIRE	517-262-1473	
CIRCUIT		CKT NO.		TLM NUMBER			CM NO.100007109176			JOB PURPOSE:		
WATER STREET		02		# OF RODS		OHMS	ORDER TYPE	MAT. TYPE	NOTIFICATION NUMBER	DESIGN NUMBER	ORDER NUMBER	
				5301031136			ERET	OHL	1065096594	11465311		
				CE STAKING REQ'D <input type="checkbox"/> Yes <input checked="" type="checkbox"/> No						UPSTREAM SECTIONALIZING DEVICE:		
				FORESTRY REQ'D <input type="checkbox"/> Yes <input checked="" type="checkbox"/> No						314-200A		
										LOCATION:		
										WESLEY N2W		
										FRANCIS		
SHEET A	SHEET 1 OF 1	SCALE 1"=100'	JACKSON	CO	SUMMIT	TWP	T 03S R 01W SEC. 03					

Page 136 of 173



MEMO TO: Mayor and City Councilmembers

FROM: Jonathan Greene, City Manager

DATE: February 7th, 2023

SUBJECT: Revoke Conditional Phase One Facility License for a Medical/Adult Use Marihuana Establishment.

Recommendation:

Revoke conditional phase one facility license for JARS Holding LLC Medical/Adult Use Marihuana Provisioning Center at 156 Cooper..

JG

DEPARTMENTAL REPORT

MEMO TO: Jonathan Greene, City Manager

FROM: Shane LaPorte, Director of Community Development

DATE: Council Meeting- February 7th, 2023

RECOMMENDATION: Approve the revocation of the previously authorized Conditional Phase One License and Development Agreement for JARS Holding LLC Medical/Adult Use Marihuana Provisioning Center at 156 Cooper..

SUMMARY

On December 8th 2020 City Council Approved a Conditional Phase one Facilities License for Medical / Adult Use Provisioning Center and Development Agreement to JARS Holdings LLC. The previous Phase1 Conditional award to JARS was based upon a competitive process. JARS had submitted plans and agreed to the Development Agreement. Over time JARS made many attempts to pair-down the development which was much different than what was submitted in the original application packet that had led to JARS being awarded the conditional phase one license. The City Attorney, Chief Building Official Building, Zoning Administrator and Engineering Department had numerous contacts with the Developers in attempt to have the project move forward. JARS has not been able to begin the project. More than two years has passed with no activity.

BUDGETARY CONSIDERATIONS

None

POSITIONS

City Staff recommends revocation.

ATTACHMENTS: Email from the applicant

JG

MEMO TO: Mayor and City Councilmembers

FROM: Jonathan Greene, City Manager

DATE: January 7th, 2023

SUBJECT: Approve Conditional Phase One Facility License for a Medical/Adult Use Marihuana Establishment as per Ordinance Section 16-516

Recommendation:

Approve conditional Phase One facility licenses for Legend Green Venture LLC. One Medical and One Adult Use Marihuana Class C Grower at 712 E South St, per Ordinance Section 16-516
Authorize the City Attorney to prepare the Development Agreement and Authorize the City Manager to sign the Development Agreement.

Based upon the due diligence on the part of City staff and the commitments on the part of the applicant, I recommend granting conditional phase one facility licenses to the above noted applicant. Your consideration and concurrence is appreciated.

Attachments:

JG

DEPARTMENTAL REPORT

MEMO TO: Jonathan Greene, City Manager

FROM: Shane LaPorte, Director of Community Development

DATE: Council Meeting- February 7th, 2023

RECOMMENDATION: Approve Conditional Phase One Facility License for a Medical/Adult Use Marijuana Establishment as Per Ordinance Section 16-516

SUMMARY

Legend Green Venture LLC submitted an application for building and site plan review for a Class C Grower Facility to be located at 712 E South St, this was done in accordance with City Ordinance Section 16-516 License Application Process and Submissions. The applicant's site and building plans were reviewed by City Staff, all plans were found to be in accordance with building and site requirements. On June 2nd 2022. The Marihuana License Committee met to review compliance with applicable ordinances that pertain to Phase 1 of the licensing process, it was determined that all criteria was met.

BUDGETARY CONSIDERATIONS

At present there are no budgetary considerations because the applicant has submitted the requisite application fee and escrow funds intended to cover the associated staff time. However, these fees are not intended to cover building permit costs, each of which will be assessed separately

HISTORY, BACKGROUND and DISCUSSION

Ordinance Section 16-516 clearly outlines the process for consideration of a marihuana facilities, including the use types, quantities, and timeframe. City Council is presently only considering the facility application (phase one) which affords the applicant the ability to seek a building permit no sooner than 30 days after Council action. Approval would also permit the City Attorney to prepare the Development Agreement and the Manager to sign the development agreement which ensures that the applicant completes the project as denoted on the plans and accompanied future operational commitments.. Building permits can be sought immediately thereafter. The subsequent review phase (entity) will not commence until a building permit is granted

POSITIONS

Staff recommends approval of Conditional Phase One Facilities License as all requirements have been met.

JG

MEMO TO: Mayor and City Councilmembers
FROM: Jonathan Greene, City Manager
DATE: February 7, 2023
SUBJECT: Approval of Doug Jones and Chris Turner's *Community of Shapes* Art Sculpture at the MLK Equality Trail near the intersection of MLK Boulevard and High Street and for the City Attorney and the Parks and Recreation Director to move forward with the artist agreement including delivery, installation and not to exceed \$30,000 contract.

Recommendation:

Approval of Doug Jones and Chris Turner's *Community of Shapes* Art Sculpture at the MLK Equality Trail near the intersection of MLK Boulevard and High Street and for the City Attorney and the Parks and Recreation Director to move forward with the artist agreement including delivery, installation and not to exceed \$30,000 contract.

Attached is a memo from Kelli Hoover, Director of Parks and Recreation regarding the MLK Equality Trail Art Sculpture.

We recommend approval of an art sculpture for the MLK Boulevard.

For the City Attorney and the Parks and Recreation Director to execute the appropriate documents. Your consideration and concurrence is appreciated.

JG

DEPARTMENTAL REPORT

MEMO TO: Jonathan Greene, City Manager

FROM: Kelli Hoover, Director Parks, Recreation and Cemeteries

DATE: February 7, 2023

RECOMMENDATION: Approval of Doug Jones and Chris Turner's *Community of Shapes* Art Sculpture at the MLK Equality Trail near the intersection of MLK Boulevard and High Street and for the City Attorney and the Parks and Recreation Director to move forward with the artist agreement including delivery, installation and not to exceed \$30,000 contract.

SUMMARY

Approval of Doug Jones and Chris Turner's *Community of Shapes* Art Sculpture at the MLK Equality Trail near the intersection of MLK Boulevard and High Street and for the City Attorney and the Parks and Recreation Director to move forward with the artist agreement including delivery, installation and not to exceed \$30,000 contract.

BUDGETARY CONSIDERATIONS

Funding for this project comes from the sale of the Greene Park Train. Total cost \$30,000.

HISTORY, BACKGROUND and DISCUSSION

The Jackson Public Arts Commission was asked to curate an art sculpture for the MLK Roundabout in June of 2022. The Commission decided to create a subcommittee and invite commissioners from the MLK Corridor Authority, Racial Equity Commission and City Council Ward person.

The Committee was formed with Arlene Robinson City Councilperson-Ward 1, Kesha Hamilton Chair of the Racial Equity Commission, George Brown Commissioner from the MLK Corridor Authority, and the Public Arts Commission Chairperson Angela Edward and Commissioner Janet Meyer-Jackman. The Committee met several times starting in July of 2022. The call for art went out nationwide in August with a due date of November 1, 2022.

The committee received 12 artist applications. Committee members reviewed each of the applications on a group scoring system set up by the Jackson Public Arts Commission. The group collaborated, shared scores and narrowed down their selections to three artists. The artists were Maxwell Emcays, Ken Thompson, Doug Jones and Chris Turner. Each artist went through zoom interviews and were allowed to submit two art pieces. After this point we planned for an open house at the MLK Center on January 4, 2023.

DISCUSSION OF THE ISSUE

Jackson City Council approved Maxwell Emcays art sculpture for the MLK Roundabout on January 24, 2023. The council asked for Doug Jones and Chris Turner's sculpture be brought back for another location on the MLK Boulevard.

POSITIONS

Requested action is for Council to award Doug Jones and Chris Turner for their *Community of Shapes* Sculpture for the MLK Equality Trail Head and MLK Boulevard intersection in the amount not to exceed \$30,000 including delivery and installation.

5-127800000
75

40.6

ph St

00000

OPTION #2

PROPOSED
SCULPTURE

S Martin
Luther King
Jr. Dr
MLK Equality Trail

OPTION #1

PROPOSED
SCULPTURE

108.5

5-1346.1000

C.T. = 23

66

Jackson Public Arts Commission
Martin Luther King Jr. Blvd Roundabout
Sculpture

Project Details

Table of contents:

Sculpture Specifications

Timeline

Budget / Payment Schedule

Insurance (example)

Site Specifications

Finished Sculpture Designs

Conceptual Sculpture Designs

Sculpture Specifications

Process and Fabrication Description

The fabrication process or work plan is comprised of several process implemented at the same time. Everything starts at the drafting of the sculpture installation. From the initial design, the refinement and scaling of the design comes into place. Once that has been established, the process of scaling design follows. Upon completion of the finalized designs, fabrication commences. Materials, vendors and assistance will be engaged. Individual components will be fabricated and assembled into the final sculpture. In conjunction with this process, site visits and consultations with the JPAC team about the foundation and progress updates will occur as necessary. Design elements and weight determinations will be forwarded as the fabrication progresses. Once the fabrication process is completed, the sculptures undergo a finishing phase before the coating process.

During fabrication, the site foundation and preparation continues with advice and consultations with the contractors and city. After inspection and approval of the foundation and installation pad has been received from the city and JPAC representatives, transportation for delivery of the final pieces from the powder coater will be scheduled for delivery to the studio for final assembly and then proceed to the site. The sculptures will be delivered and installed under my supervision, in coordination with the City of Jackson Building and Engineering inspectors. Following MiOSHA regulations and procedures the sculptures will be installed. Collaborating with the JPAC team, suggestions for lighting the pieces, and final landscaping design is completed. A final check and polishing will occur before acceptance.

Jackson Public Arts Commission
Martin Luther King Jr. Blvd-Roundabout Sculpture
Project Committee

Timeline:

January 2023

Project Confirmation
Insurance
Contract
Permits/Excavation (Foundation)
Begin fabrication process

February

JPAC/MLKRS project updates (meetings-studio visits).
Fabrication continues
Site visit (confirm foundation specs).
Attachment bolts with subgrade anchors.

March

JPAC/MLKRS project updates (site visits-logistics).
Prepare and pouring of sculpture foundation/curing time
Fabrication continues
Metal finishing stage begins
Above grade galvanized pedestals (fabricating).

April

Powdercoating/Exterior finishing of sculptures
Site preparation

JPAC/MLKRS updates (finishing/installation/transportation).

April/May

Finishing/installation

Transport finished sculptures to site for installation.

Careful packing and securing of all related components and installation equipment.

Finished sculptures installed.

Final inspection and sign off

Project completion

Jackson Public Arts Commission
Martin Luther King Jr. Blvd-Roundabout Sculpture
Project Committee

Budget:

Permits,accounting,logistics and legal.	\$4500
Design,Artwork purchase,operating costs.	\$11,000
Materials,fabrication equipment,consumables.	\$5000
Installation,site preparation,labor.	\$4000
Transportation,outsourcing,ect.	\$2500
Equipment,specific tools required.	\$1000
Finishing process,galvanizing,powder coating.	
 Budget Grand Total:	 \$30,000

Payment schedule:

50% of total budget (\$15,000) is required to begin the fabrication and construction process.

25% of remaining balance (\$7500) will be required towards the halfway point of the project.

25% of the total budget which is the balance (\$7500) will be required upon completion of the project installation and agreement of JPAC and MLKRS Project Committee

This budget payment schedule has been made specifically for this project.

Thank you.



* FOUNDATIONS
↓
DETAILS

PLAN VIEW

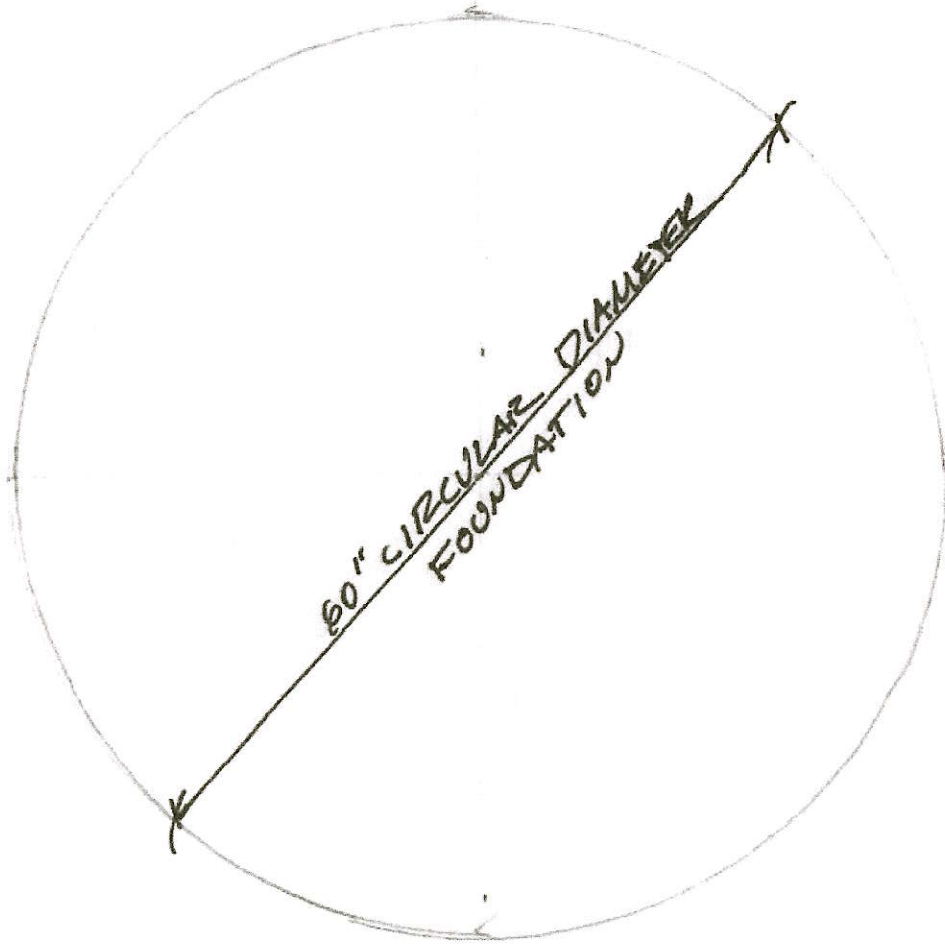

ABOVE
GRADE

6"

LEVEL CONCRETE
SURFACE

ABOVE
GRADE

BELOW
GRADE

42"

48"
TOTAL

ELEVATION

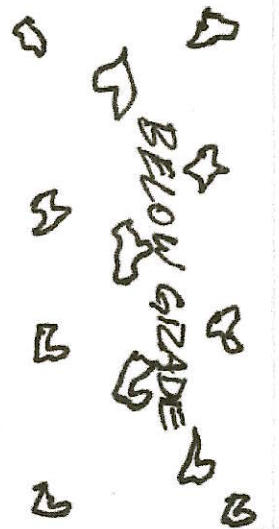

FROST LINE @ 42" DEPTH

③ GALVANIZED 1/4" THICK SCULPTURE PEDISTALS

* GALVANIZED MOUNTS
48" TALL EACH

* ADDRESSES
SAFETY ISSUES

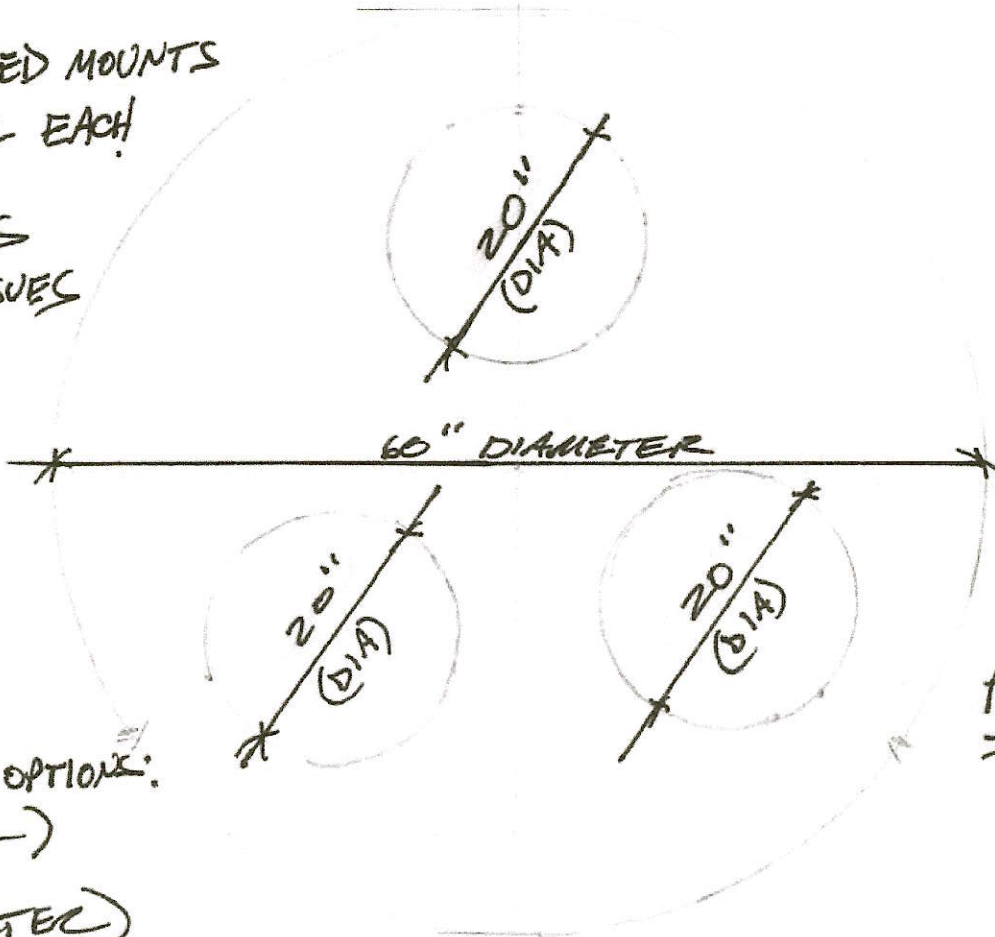

PLAN VIEW

* LIGHTING OPTIONS:
(CENTER)
(PERIMETER)
TBD

* SCULPTURE MOUNTS
VIA HEAVY DUTY
NON-FERROUS HARDWARE

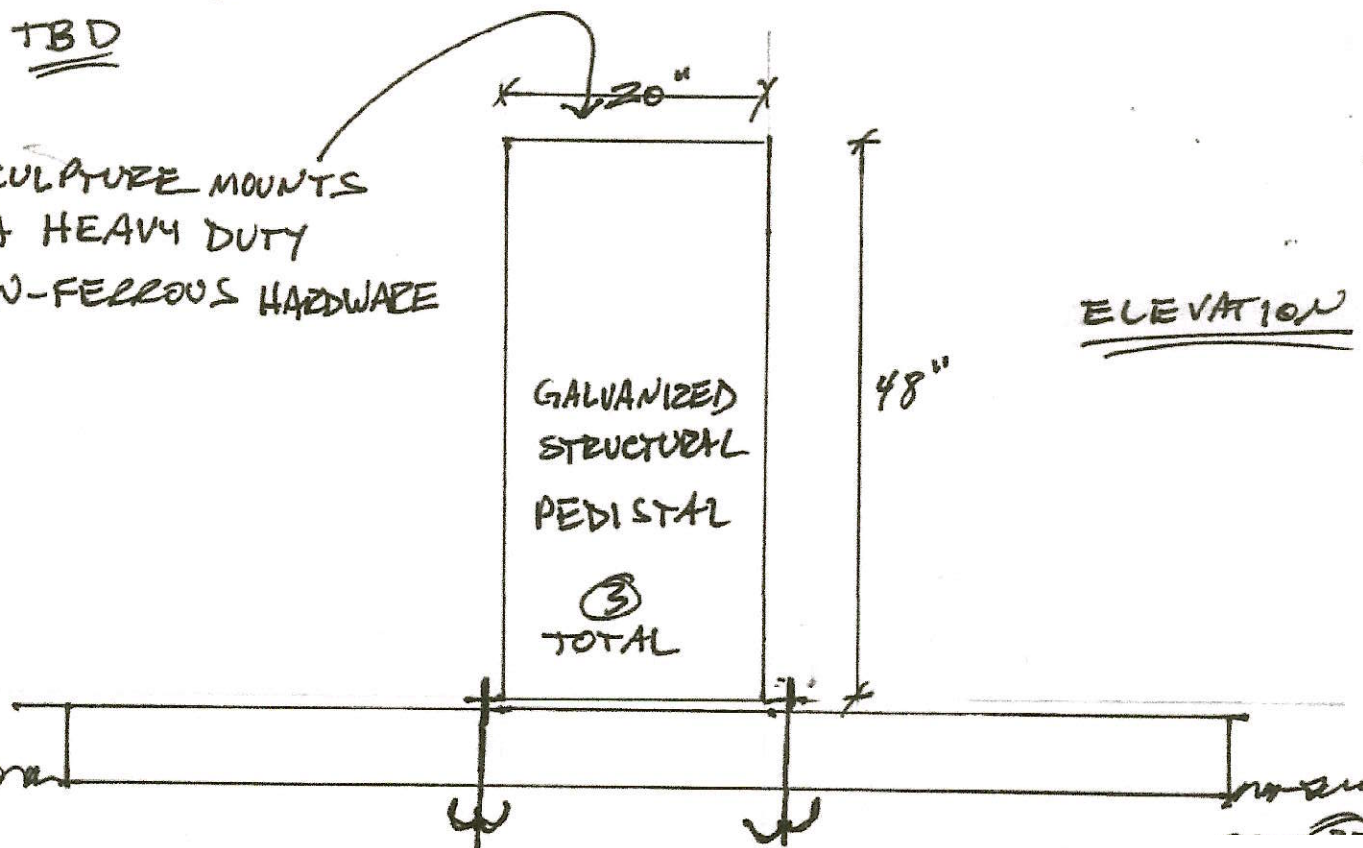

ELEVATION

VARIES (66' - 201') ROW

DIAMETER

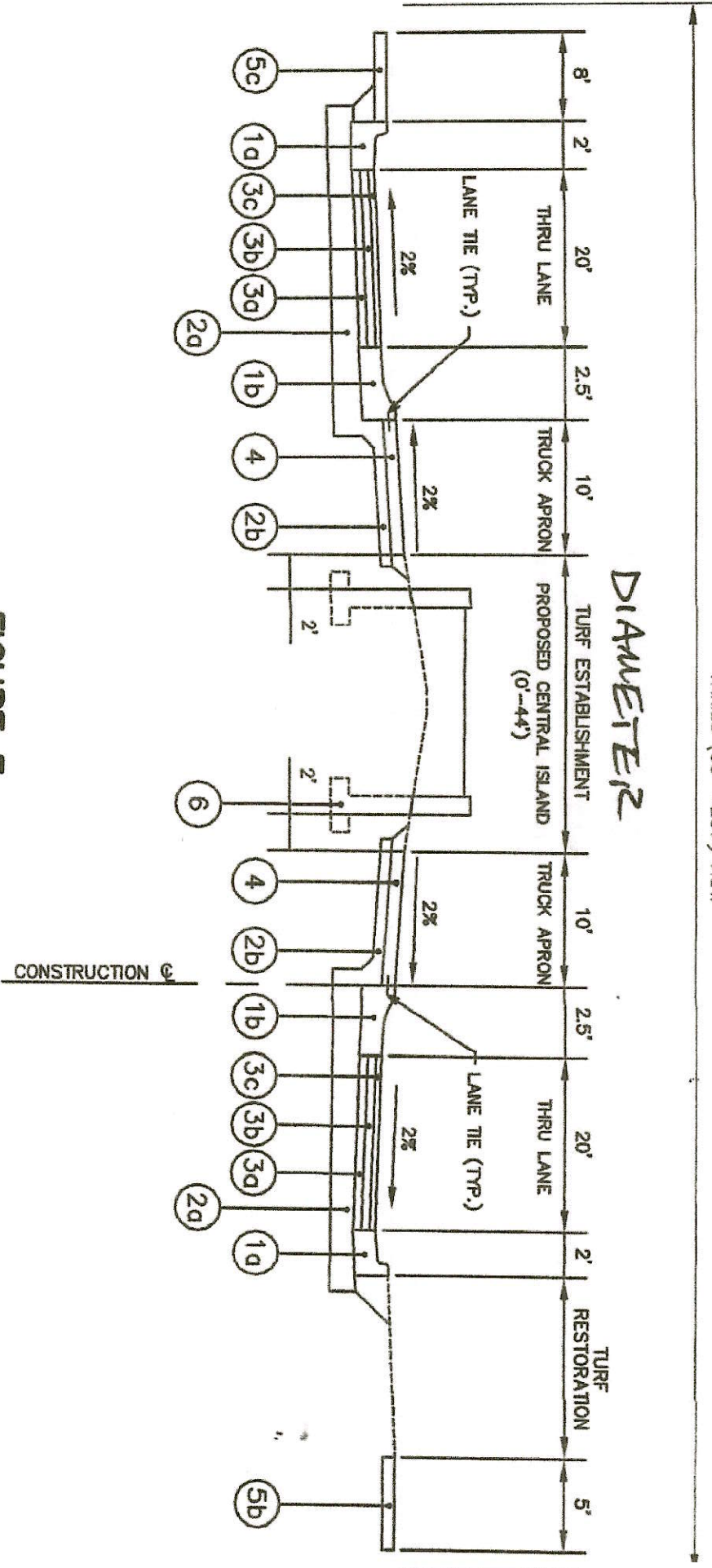
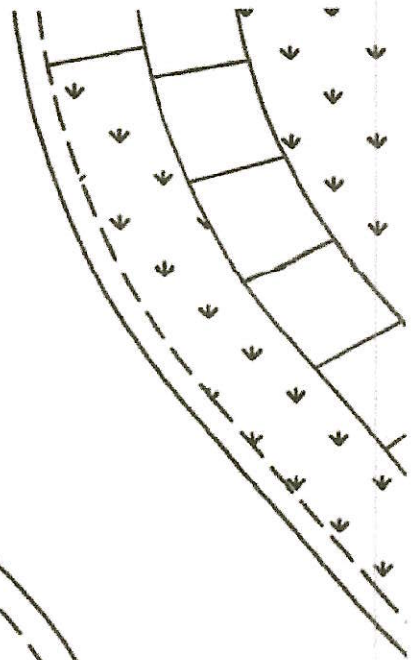
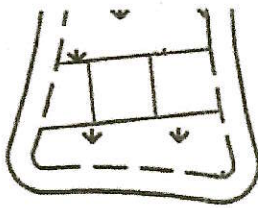
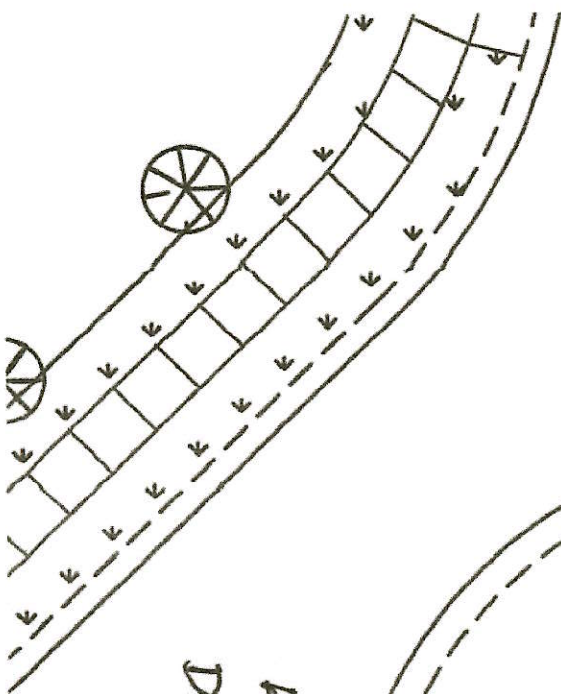
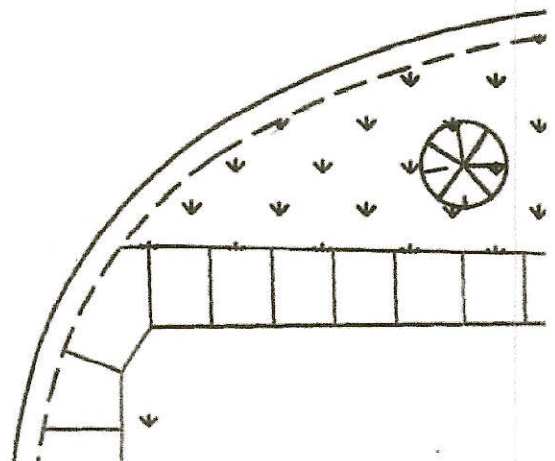
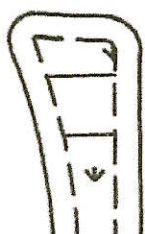
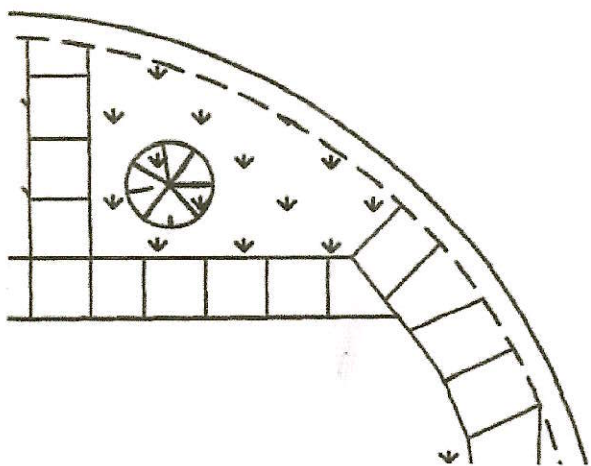
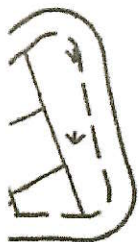
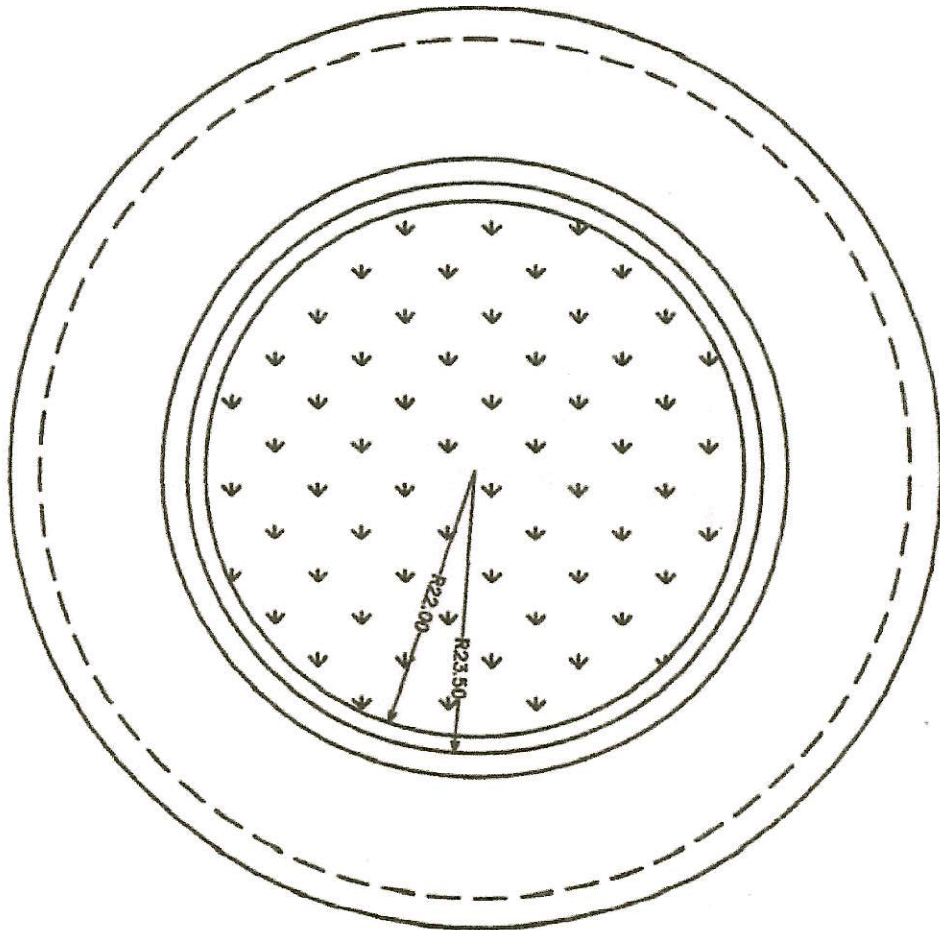

FIGURE F

TYPICAL CROSS SECTION OF PROPOSED CONSTRUCTION
STA 101+66 TO STA 102+85
ON MARTIN LUTHER KING JR DRIVE
STA 12+28 TO STA 13+64
ON MORRELL STREET



RADIUS = 22'
 DIAMETER = 44'



ORIGINAL SCULPTURE DESIGN

#7

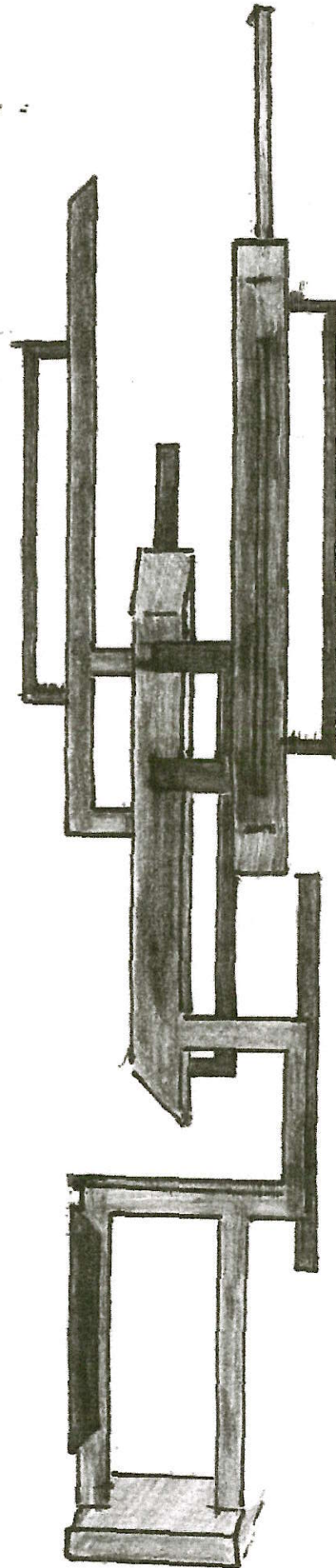

C. TURNER

ORIGINAL SCULPTURE DESIGN

#2

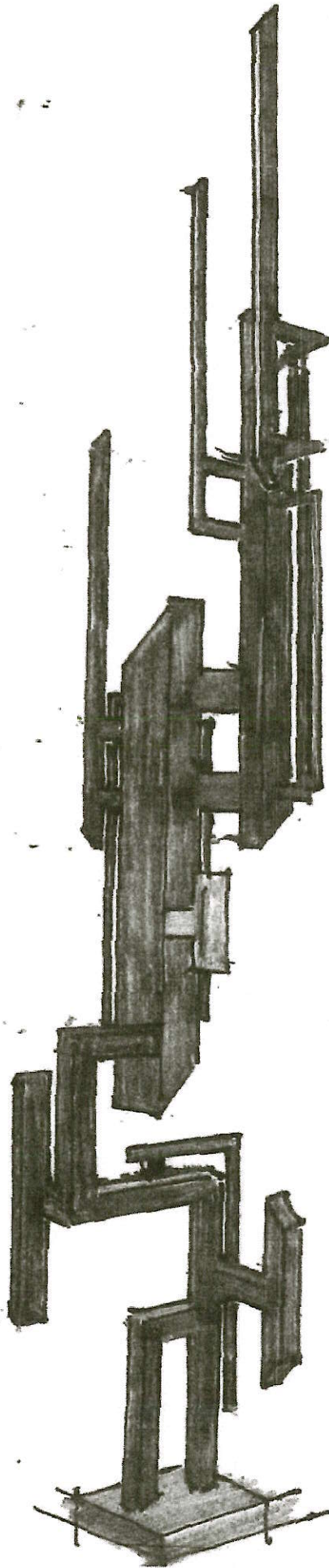

C. TURNER
2022

ORIGINAL SCULPTURE DESIGN

#3

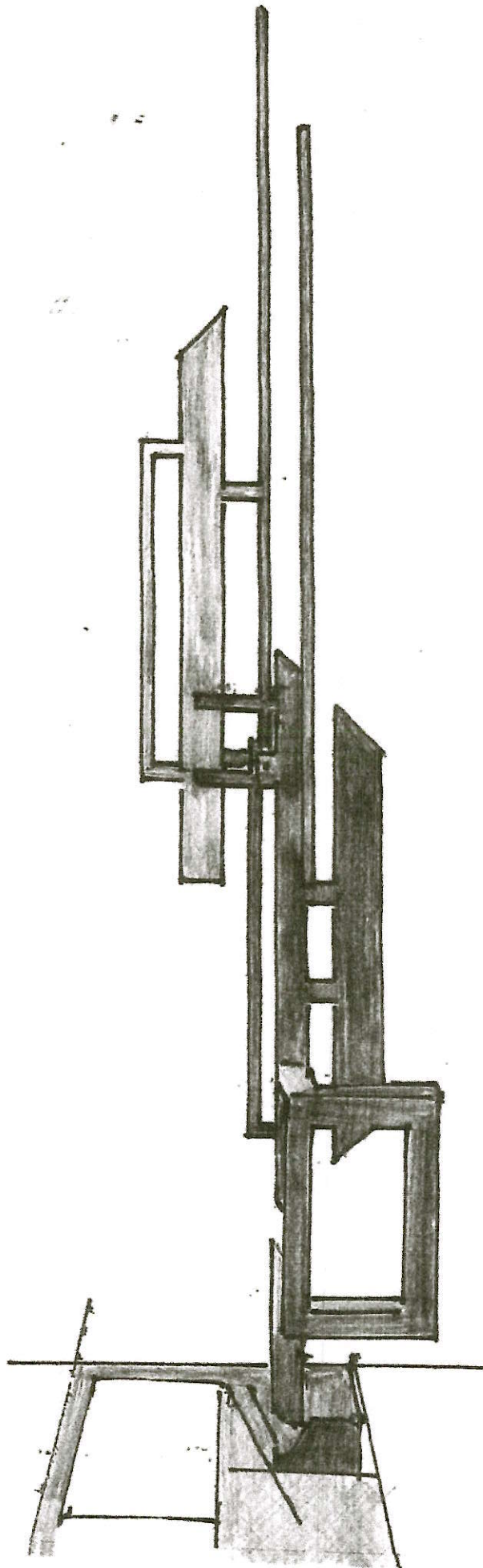

C. TURNER
2022

ORIGINAL SCULPTURE DESIGN
"A COMMUNITY OF SHAPES"

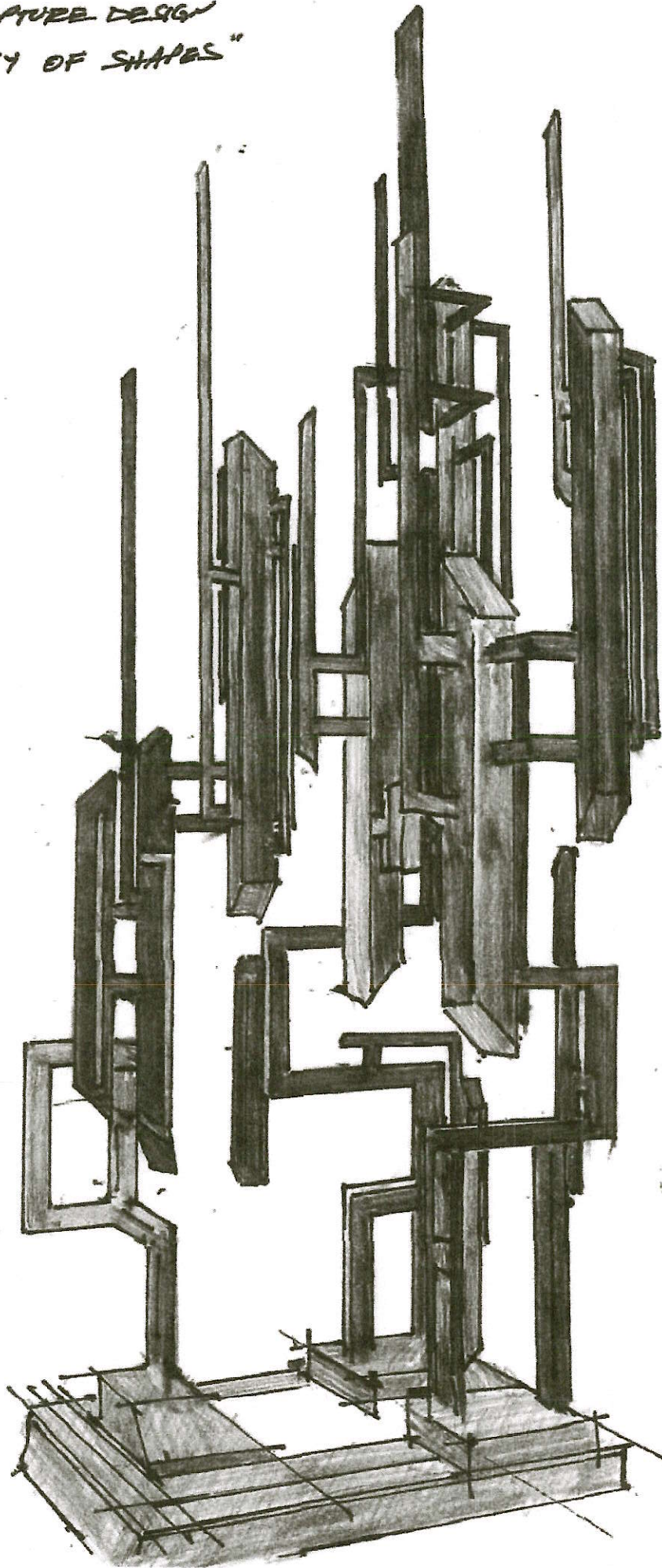

#4

C. TURNER

"A COMMUNITY OF SHAPES"

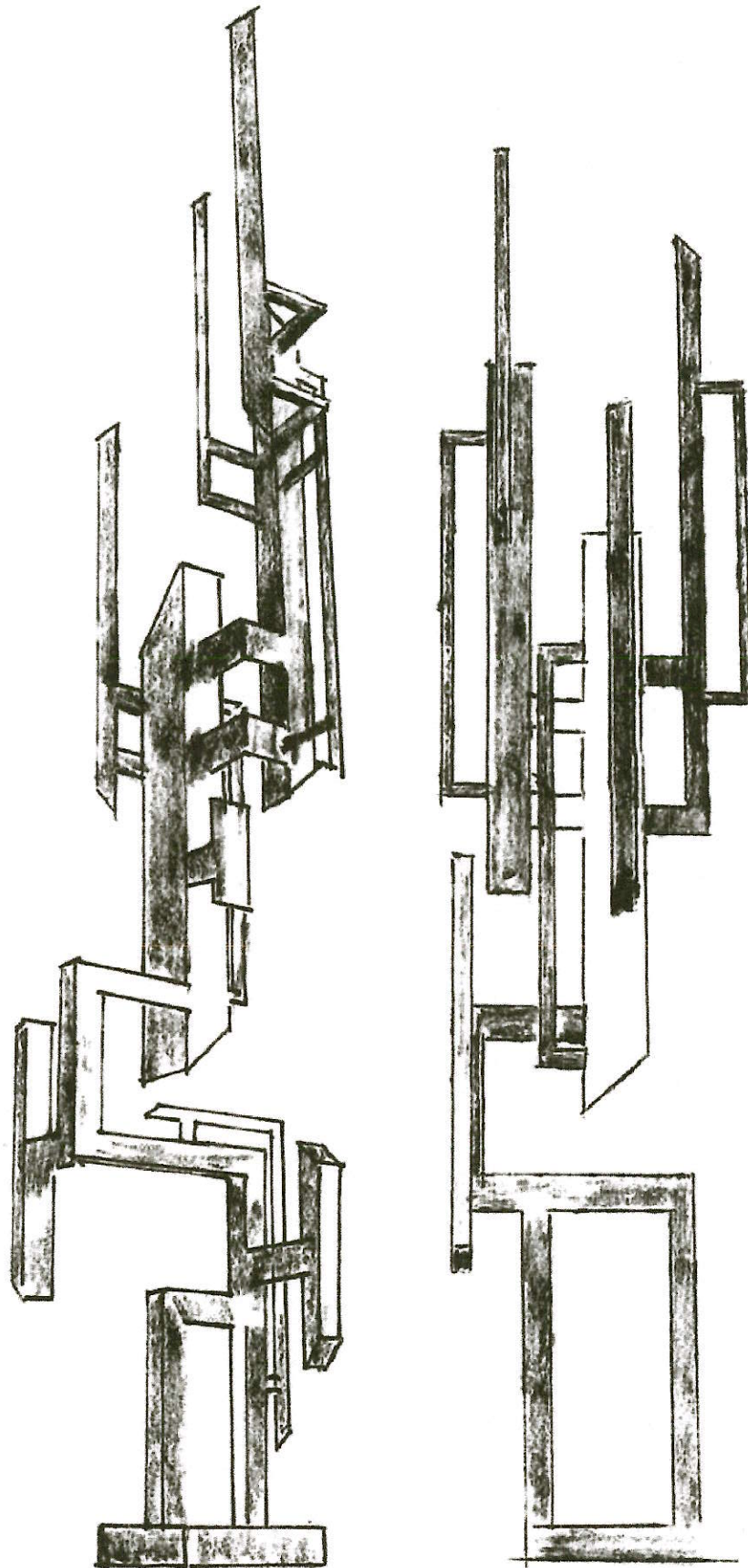

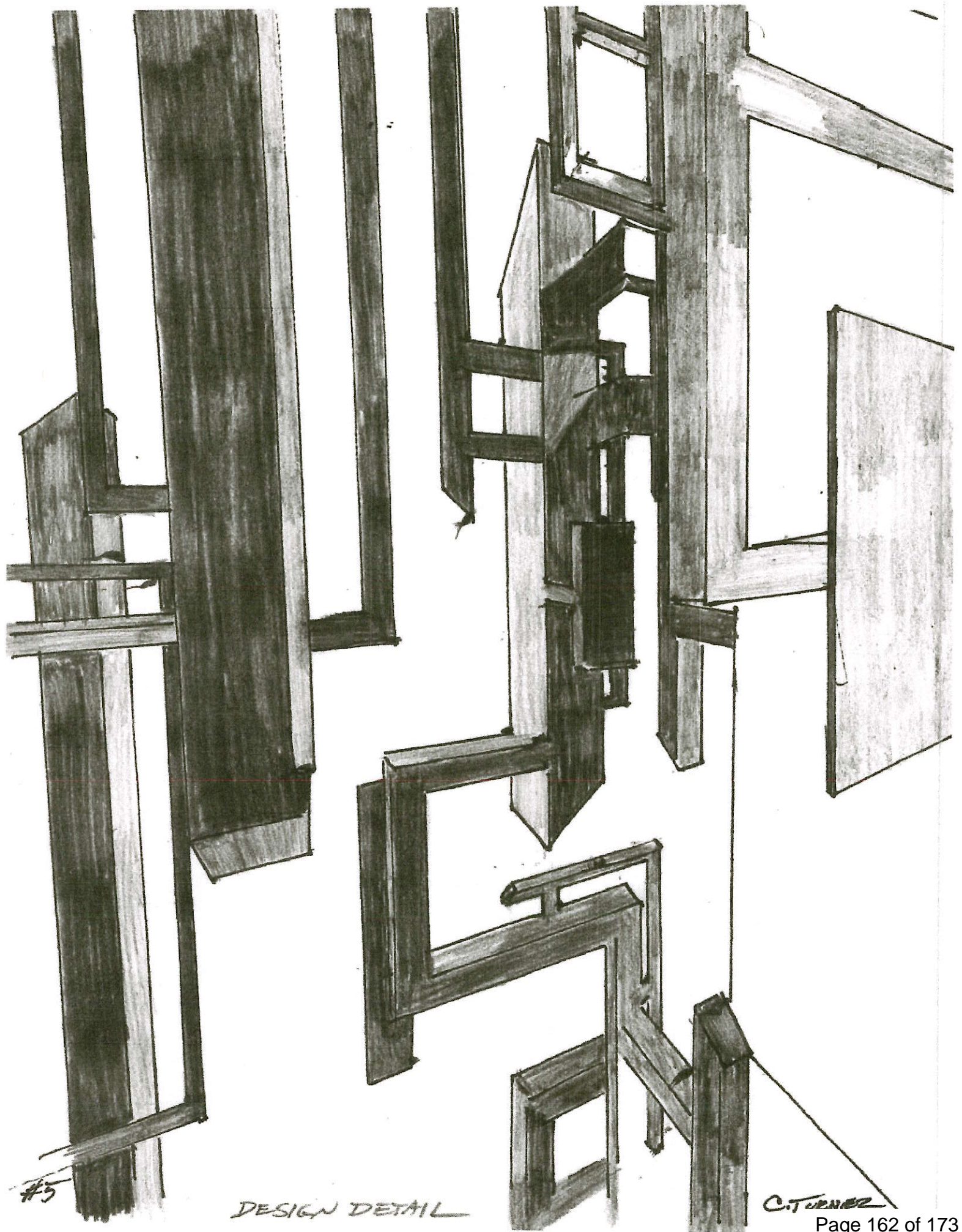

#5

DESIGN DETAIL

C. TURNER

CONCEPT DRAWING
#7

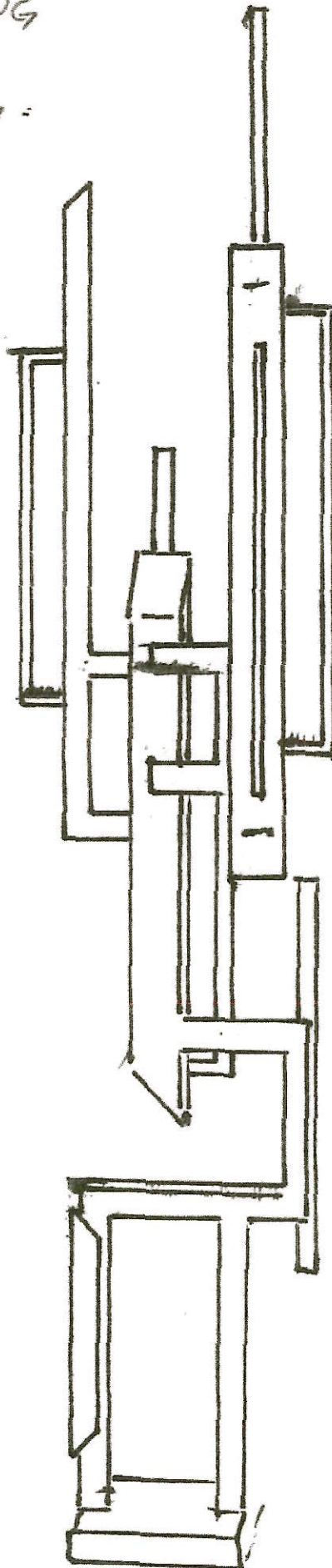

CT 12

CONCEPT DRAWING
#2

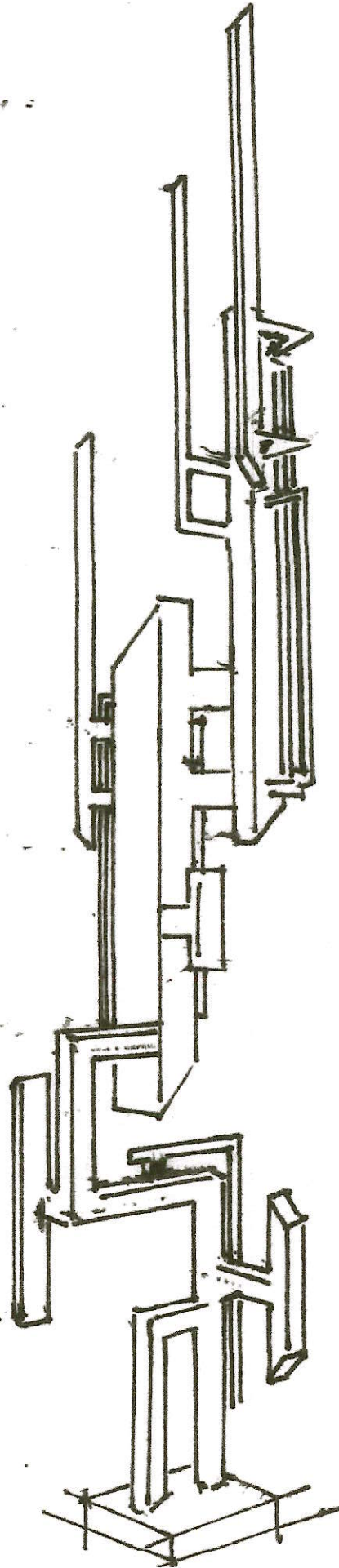

CT (22)

CONCEPT DRAWING
#3

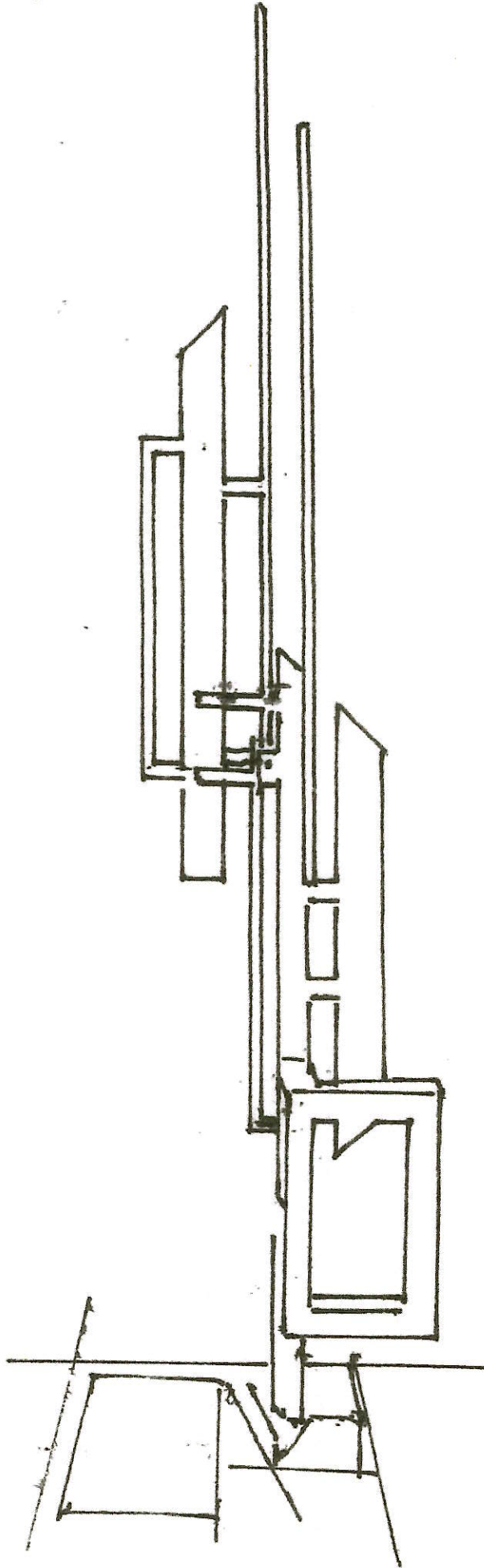

CONCEPT DRAWING
#4

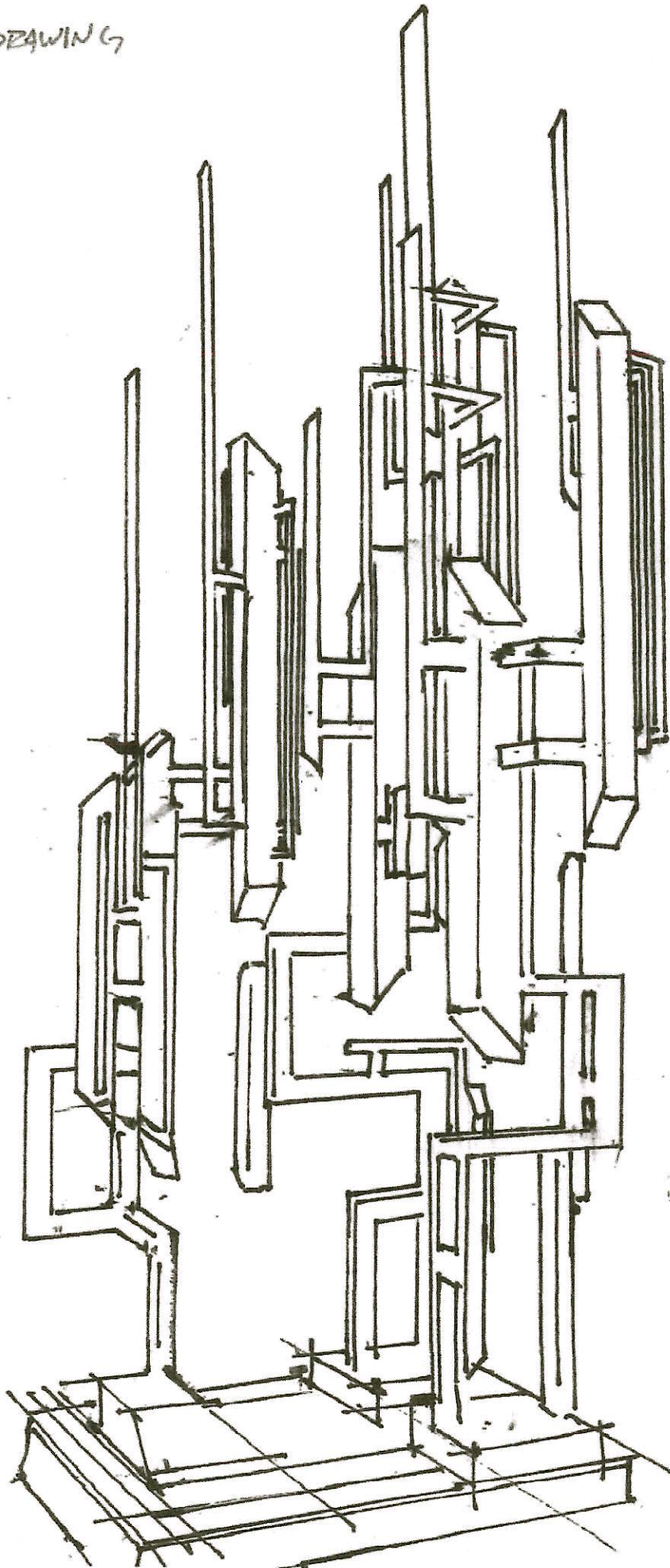

CONCEPT DRAWING
#15

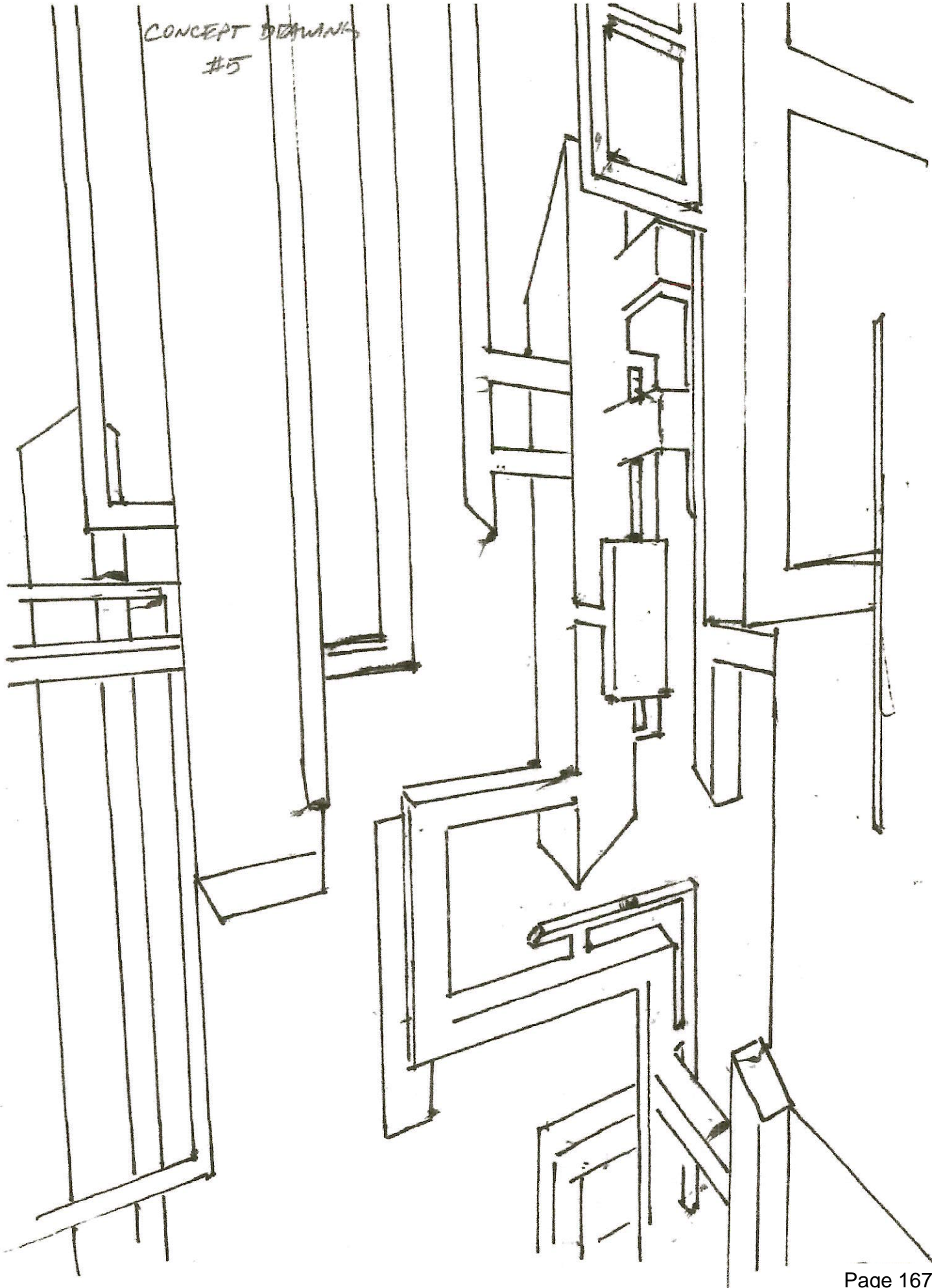

MEMO TO: Mayor and City Councilmembers

FROM: Jonathan Greene, City Manager

DATE: Council Meeting – February 7, 2020

SUBJECT: Resolution for “No Mow May” in the City of Jackson

Recommendation: Do not approve the resolution for “No Mow May” in the City of Jackson.

Attached is a memo from Mike Osborn. Your consideration and concurrence is appreciated.

MEMO TO: Jonathan Greene, City Manager
FROM: Michael Osborn, Director of Public Works
DATE: January 6, 2023
SUBJECT: **No Mow May**

Mr. Greene,

As the Director of Public Works, it is my duty to oversee mowing including the city owned properties and enforcement of violations covered under the mowing ordinance, as such I feel it is important to bring the disadvantages of “No Mow May” to your attention.

Numerous ramifications of delaying the start of mowing season would result from a “No Mow May”. The blight would be extensive, as the city owns 637 properties along with 52 public properties that would not receive any attention during the heart of the growing season. All properties that have a month’s worth of growth during the heaviest growth season would result in excessive height and cleanup charges (covered in the mowing contracts). Both the city mowing budget and the customers would absorb these costs. The contractors would work well into June and July to try to “catch up” with list completion and ordinance violations. “No Mow May”, I’m afraid would turn into “No Mow Summer”.

Last May (2022), our department received 371 complaints on private properties alone resulting in the contractors completing 143 of them. My concern is that this number would surely increase once the residents realized that the standard lawn mower would not be able to handle the height or thickness of the grass they would be attempting to cut at the end of May. Then there is the problem with all the additional clippings which would end up in the gutter pan resulting in clogged catch basins. Furthermore, we would have to decide how to handle all the lawn clippings that produced from such growth and more than likely end up on the right of ways or in the streets. Allowing such an overgrowth could increasing nuances’ such as rodents, fleas, ticks and illegal dumping. Several department heads along with our City Planner are in agreement that “No Mow May” is not feasible for the City of Jackson.

After careful consideration it is my firm opinion that the problems associated with “No Mow May”, far out way the benefits in the City of Jackson.

Thank you for your consideration,

Michael Osborn
City of Jackson
Director of Public Works

CITY OF JACKSON ENVIRONMENTAL COMMISSION

161 W. MICHIGAN AVENUE, JACKSON, MICHIGAN 49201

September 21, 2022

City Council
City of Jackson
161 W Michigan Avenue
Jackson, MI 49201

RE: No Mow May in the City of Jackson

Dear City Council:

The Environmental Commission recommends City Council consider implementing No Mow May starting in May 2023.

No Mow May is a conservation initiative where people refrain from mowing their lawns during the month of May - this allows grass to grow creating habitat for early season pollinators. This is particularly important in urban areas where there are limited spaces for growth.

Communities in Michigan are already getting on board with No Mow May - in 2022 the cities of Albion and Ann Arbor adopted No Mow May. Additional information can be found at <https://www.beecityusa.org/no-mow-may/> or on the City of Albion and/or City of Ann Arbor websites.

RESOLUTION 2023-XX

WHEREAS, the Jackson City Council recognizes that bees and other pollinators are integral to pollination of plants in order to grow a wide diversity of essential foods including fruit, nuts, and vegetables; and

WHEREAS, pollinator populations are threatened due to habitat loss, pathogens, and parasites; and

WHEREAS, recent research suggests that bee pollinators make use of no mow spaces as key floral resources during early spring in the Midwest United States; and

WHEREAS, pollinators and floral resources have a positive relationship, where the increase in pollinators can increase the amount of flora and vice-versa; and

WHEREAS, the City Council finds it is in the public interest and consistent with adopted City policy for the City to demonstrate its commitment to a safe and healthy community environment through the implementation of initiatives that help increase the pollinator population;

THEREFORE BE IT RESOLVED, that Jackson City Council declares “No Mow May,” and encourages property owners to refrain from mowing the open spaces in their rear yards from May 1st until May 31st, 2023; and

THEREFORE BE IT RESOLVED, that the No Mow May initiative does not apply to violations of city ordinance that affect public safety under Jackson City Code; and

THEREFORE BE IT RESOLVED, that Jackson City Council directs City Administration to refrain from issuing citations for tall grass in property owners’ rear yards from May 1st until May 31st, 2023.

MEMO TO: Mayor and City Councilmembers

FROM: Jonathan Greene, City Manager

DATE: February 7, 2023

SUBJECT: Approve the sale of City Owned property located at 352 N. Grinnell Street, 823 Maltby Street, 612 E. Ganson Street and 704 E. Ganson Street to Fresh Start Real Estate Services, LLC.

Recommendation: Approve the sale of City owned property for \$300 per lot, located at 352 N. Grinnell Street, 823 Maltby Street, 612 E. Ganson Street and 704 E. Ganson Street to Fresh Start Real Estate Services, LLC for the purpose of building four new, single family homes. Authorize the City Attorney to create the Property Transfer Agreement and any other authorized documents to complete the sale of the property; authorize the City Manager to sign Property Transfer and other related documents.

Attached is a report from Lisa Moutinho. Your consideration and concurrence is appreciated.

DEPARTMENTAL REPORT

MEMO TO: Jonathan Greene, City Manager

FROM: Lisa Moutinho, Administrative Assistant to the City Manager

DATE: February 7, 2023

RECOMMENDATION: Approve the sale of City owned property located at 352 N. Grinnell Street, 823 Maltby Street, 612 E. Ganson Street and 704 E. Ganson Street to Fresh Start Real Estate Services, LLC, and authorize the City Attorney to prepare property transfer documents; authorize the City Manager to sign property transfer documents.

SUMMARY

The City of Jackson proposes to sell a four parcels of vacant land located at 352 N. Grinnell Street, 823 Maltby Street, 612 E. Ganson Street and 704 E. Ganson Street to Fresh Start Real Estate Services, LLC, for the purpose of building four, single family homes.

HISTORY, BACKGROUND and DISCUSSION

Fresh Start Real Estate Services, LLC would like to purchase the vacant lots at 352 N. Grinnell Street, 823 Maltby Street, 612 E. Ganson Street and 704 E. Ganson Street to build a single family home on each lot. City staff is proposing for the Council to sell the vacant lots subject to a Development Agreement. If Fresh Start Real Estate Services, LLC were to default on the terms of the Development Agreement, and not cure the default in the proper amount of time, then the property would revert to City ownership.

POSITIONS

Requested action is for City Council to approve the sale of 352 N. Grinnell Street, 823 Maltby Street, 612 E. Ganson Street and 704 E. Ganson Street to Fresh Start Real Estate Services, LLC for the purpose of construction of one, single family home per lot.
