



AGENDA- CITY COUNCIL

Tuesday, July 11, 2023
6:30 PM

Page

1. CALL TO ORDER.

2. PLEDGE OF ALLEGIANCE.

Invocation will be given by 3rd Ward Councilmember Angelita Gunn



3. ROLL CALL.

4. ADOPTION OF AGENDA.





5. PRESENTATIONS/PROCLAMATIONS.

6. PUBLIC HEARINGS.

Recess as a City Council and convene as a Board of Review

- | | | |
|-----|-----------------------------------------------------------------------------------------------------------------------------------------------------------------------------------------------------------------------------------------------------------------------------------------------------------------------------------------------------------------------------------------------------------------------------------------------------------------------------------------------|---------|
| 6.1 | Special Assessment Roll No. 3426 - Arnold Street
SA Roll No 3426 agenda item.pdf 
Open public hearing for Special Assessment Roll No. 3426
Close the public hearing for Special Assessment Roll No. 3426
Approve the resolution confirming Special Assessment Roll No. 3426 for street reconstruction and water main replacement on Arnold Street from Cooper to the east end. | 8 - 11 |
| 6.2 | Special Assessment Roll No. 3427 - Biddle Street
SA Roll No 3427 agenda item.pdf 
Open public hearing for Special Assessment Roll No. 3427
Close the public hearing for Special Assessment Roll No. 3427
Approve the resolution comfirming Special Assessment Roll | 12 - 14 |

No. 3427 for street reconstruction and water and sewer main replacement on Biddle from Greenwood to Williams.

- 6.3 Special Assessment Roll No. 3428 - Burr Street Cooper to State 15 - 20
[SA Roll No 3428 agenda item.pdf](#) 
Open public hearing for Special Assessment Roll No. 3428
Close the public hearing for Special Assessment Roll No. 3428
Approve the resolution confirming Special Assessment Roll No. 3428 for street reconstruction and water and sewer main replacement on Burr Street, Cooper to State.
- 6.4 Special Assessment Roll No. 3429 - Burr Street, State to Waterloo 21 - 23
[SA Roll No 3429 agenda item.pdf](#) 
Open public hearing for Special Assessment Roll No. 3429
Close the public hearing for Special Assessment Roll No. 3429
Approve the resolution confirming Special Assessment Roll No. 3429 for street reconstruction and water and sewer main replacement on Burr Street, State to Waterloo
- 6.5 Special Assessment Roll No. 3430 - Deyo Street 24 - 28
[SA Roll No 3430 agenda item.pdf](#) 
Open public hearing for Special Assessment Roll No. 3430
Close the public hearing for Special Assessment Roll No. 3430
Approve the resolution confirming Special Assessment Roll No. 3430 for street reconstruction and water and sewer main replacement on Deyo Street, Elm to Gorham
- 6.6 Special Assessment Roll No. 3431 - Dwight Street 29 - 32
[SA Roll No 3431 agenda item.pdf](#) 
Open public hearing for Special Assessment Roll No. 3431
Close the public hearing for Special Assessment Roll No. 3431
Approve the resolution confirming Special Assessment Roll No. 3431 for street reconstruction and water main replacement on Dwight Street, Chapin to Tyson
- 6.7 Special Assessment Roll No. 3435 - Grinnell 33 - 36

[SA Roll 3435 agenda item.pdf](#) 

Open public hearing for Special Assessment Roll No. 3435

Close the public hearing for Special Assessment Roll No. 3435

Approve the resolution confirming Special Assessment Roll No. 3435 for street reconstruction and water main replacement on Grinnell, Norfolk to Wildwood

6.8 Special Assessment Roll No. 3436 - McBride 37 - 41

[SA Roll No 3436 agenda item.pdf](#) 

Open public hearing for Special Assessment Roll No. 3436

Close the public hearing for Special Assessment Roll No. 3436

Approve the resolution confirming Special Assessment Roll No. 3436 for street reconstruction and water main replacement on McBride, Fourth to First Street.

6.9 Special Assessment Roll No. 3439 - Williams Street 42 - 43

[SA Roll 3439 agenda item.pdf](#) 

Open public hearing for Special Assessment Roll No. 3439

Close the public hearing for Special Assessment Roll No. 3439

Approve the resolution confirming Special Assessment Roll No. 3439 for street reconstruction and water and sewer main replacement on Williams, Biddle to Wilkins Street.

Adjourn as a Board of Review and reconvene as City Council

7. CITIZEN COMMENTS.

(3-Minute Limit)

8. PETITIONS & COMMUNICATION FROM CITY STAFF AND OTHER GOVERNMENTAL ENTITIES.

(Accept and Place on File)

8.1 City of Jackson, Michigan Financial Statements as of and for the 11 Months Ended May 31, 2023 44 - 51







[Monthly Fin Stmts 2023-05-31.pdf](#) 

8.2 CDBG, HOME, & CV Financial Summaries for May 2023

[May 2023 - CDBG, Home, & CV Financial Summaries.pdf](#) 

9. CONSENT CALENDAR

Consent Action

- 9.1 Minutes of the Regular Meeting of June 13, 2023 Council Meeting 52 - 62
[CCMIN 6.13.23.pdf](#) 
Approve the meeting minutes from the June 13, 2023 City Council Meeting.
- 9.2 Recognition of Jackson Area Hockey Association as a non-profit organization 63 - 64
[Jackson Area Hockey Association.pdf](#) 
Approve a resolution recognizing Jackson Area Hockey Association as a non-profit organization.
- 9.3 Local Governmental Unit Approval for Social District Permit 65 - 66
[Tilted social district resolution packet.pdf](#) 
Adopt a resolution recommending the Michigan Liquor Control Commission consider approving a Social District Permit for Tilted Arcade Bar.
- 9.4 Special Event Application: Jackson Hispanic Heritage Festival 67 - 73
[SEA--Hispanic Heritage Festival.pdf](#) 
Approve a request from Nuestra Comunidad to host their Jackson Hispanic Heritage Festival event on September 16, 2023, in Horace Blackman Park, the True Community Credit Union City Square, and on the streets of downtown Jackson.
- 9.5 Special Event Application: Relay for Life 74 - 81
[SEA--Relay For Life 2023.pdf](#) 
Approve a request from the American Cancer Society to host their Relay for Life event July 28-29, 2023, in and around Sparks Foundation Park.
- 9.6 Special Event Application: Veteran Suicide Prevention Ruck March 82 - 91
[SEA--Veteran Ruck March.pdf](#) 
Approve a request from the Jackson County Military Coalition to host their Veteran Suicide Prevention Ruck March on September 09, 2023, on the sidewalks/crosswalks of Jackson.

- 9.7 Special Event Application: Home of New Vision Recovery Out Loud Walk 92 - 100
[SEA--Recovery Outloud Annual Walk.pdf](#) 

Approve a request from the Home of New Vision to host their Recovery Out Loud Walk on September 9, 2023, on the streets/sidewalks of Jackson.

- 9.8 Special Event Application: Downtown Day 101 - 107
[SEA -- Downtown Day.pdf](#) 

Approve a request from the Jackson Downtown Development Authority to host Downtown Day on July 30, 2023 in Horace Blackman Park, Bucky Harris Park, and various downtown sidewalks/parking lots.

10. OTHER BUSINESS.

11. NEW BUSINESS.

- 11.1 Public Works Forestry Services contract extension with Johnny's Tree Service, Inc. 108 - 110

[Johnny's Tree Service extension 2023.pdf](#) 

Approval of the one-year contract extension with Johnny's Tree Service, Inc., for as needed tree trimming, tree removals, and stump grinding, with a 2.5% increase for an estimated cost of \$206,800 for the fiscal year 2023/24.

- 11.2 Purchase of 4,000 tons of road salt for the 2023/2024 winter season 111 - 115

[Road Salt Purchase 2023-24.pdf](#) 



Approve the purchase of 4,000 tons of road salt from Detroit Salt Company at a cost of \$77.87 per ton for a total amount of \$311,480, for the 2023/2024 winter season through cooperative bidding with the Jackson County Department of Transportation.

- 11.3 Award the Loomis Park Playground Project Phase 2 Change Order 2 to R.W. Mercer of Jackson, Michigan in the lesser amount of -\$8,005.00. 116 - 118

[Loomis Park Playground Change Order 2 Agenda lteam.pdf](#)



Award the Loomis Park Playground Project Phase 2 Change Order 2 to R.W. Mercer of Jackson, Michigan in the lesser amount of -\$8,005.00.

- | | | |
|------|-----------------------------------------------------------------------------------------------------------------------------------------------------------------------------------------------------------------------------------------------------------------------------------------------------------------------------------------------------------------------------------------------------------------------------------------------------------------------------------------------------------------------------------------------------------------------------------------------------------------------------------------------|-----------|
| 11.4 | <p>Professional Engineering Services Contract with Fishbeck, for Construction Administration Services for the Drinking Water State Revolving Fund</p> <p>DWSRF Construction Admin Fishbeck.pdf </p> <p><i>Approval of Professional Engineering Services Contract with Fishbeck, for Construction Administration of the Fiscal Year 2023 Drinking Water State Revolving Fund Improvement projects at a not to exceed amount of \$134,000.</i></p> | 119 - 128 |
| 11.5 | <p>Region 2 Planning Commission Invoice – Local Share Cost of JACTS Unified Work Program FY 2023</p> <p>Engineering JACTS Local Share UWP Invoice Region 2.pdf </p> <p><i>Approve payment of the invoice from Region 2 Planning Commission for local share cost of Jackson Area Comprehensive Transportation Study (JACTS) Unified Work Program for FY 2022, in the amount of \$24,508.00, in accordance with the recommendation of the City Engineer, and authorize the City Engineer to sign the Local Funding Resolution.</i></p> | 129 - 133 |
| 11.6 | <p>Change Order No. 1 to the Wastewater Treatment Plant Clean Water State Revolving Fund 2022 Improvements Contract with Allied Mechanical Services, Inc.</p> <p>CWSRF-Allied Contract Change Order #1.pdf </p> <p><i>Approval of Change Order No. 1 to the Wastewater Treatment Plant Clean Water State Revolving Fund 2022 Improvements Contract with Allied Mechanical Services, Inc. in the increased amount of \$158,668, and authorize the City Manager and Director of Public Works to execute the appropriate documents.</i></p> | 134 - 219 |
| 11.7 | <p>2023/2024 Nonunion Pay Scale</p> <p>Nonunion Wage Increase 2023-07-01.pdf </p> <p><i>Adopt an ordinance regulating nonunion pay for the City of Jackson employees</i></p> | 220 - 223 |
| 11.8 | <p>Approve Conditional Phase 1 Facility License</p> <p>Council Packet Phase 1 license application Five Point Farms LLC.pdf </p> <p><i>Approve conditional phase one license for Five Point Farms, LLC, Marihuana Microbusiness at 744 E. South Street, per Ordinance No. 2020-15. Authorize the City Manager to sign the Development Agreement and make minor modifications as necessary.</i></p> | 224 - 229 |

12. CITY COUNCILMEMBER'S COMMENTS.

13. MANAGER'S COMMENTS.

14. ADJOURNMENT.

RESOLUTION
STREET RECONSTRUCTION AND WATER MAIN REPLACEMENT ON ARNOLD STREET

BY THE BOARD OF REVIEW:

WHEREAS, the Assessor, in accordance with the direction of the City Council, did prepare special assessments concerning street reconstruction and water main replacement on Arnold Street, from Cooper Street to east end which assessments were by him placed on Assessment Roll No. 3426 in the amount of \$177,497.29 and reported to the City Council as its meeting held on the 11th day of July, 2023; and

WHEREAS, notice has been duly given that the City Council and Assessor would sit as a Board of Review in the Council Chambers in the City of Jackson on Tuesday, July 11, 2023, at 6:30 p.m. to hear any and all objections and suggestions by interested parties to said special assessment as contained in said roll; and

WHEREAS, the matter of said review having come on to be heard and the City Council and Assessor sitting as a Board of Review having heard all suggestions and objections made thereto and having fully considered the same;

NOW, THEREFORE, BE IT RESOLVED, that each and all of the special assessments as contained in said roll are hereby confirmed and made valid liens against the property and valid claims against the owners thereof, and the City Clerk is hereby directed to make certificates of this determination and attach the same to said roll and to turn said roll over to the City Treasurer for collection; and

BE IT FURTHER RESOLVED that each and all of the special assessments contained in Roll No. 3426 shall be divided into 10 equal installments, the first of which shall be payable by the first summer tax bill following the date of the confirmation without interest charge; and the remaining installments, plus a 2.75% annual interest charge on each installment, shall be due annually each subsequent year at the same times with the same installments as the summer tax bill until each of the special assessments has been paid in full; provided, however, that in the event the City issues bonds in anticipation of special assessments, the unpaid balance of said special assessments shall, in accordance with Section 22-9 of the Jackson City Code of Ordinances, bear a rate of interest which may not be in excess of six percent (6%) per annum, or one percent (1%) above the average interest cost of said special assessment bonds.

BE IT FURTHER RESOLVED that the unpaid balance of any special assessment, including pro rata interest charges, may be paid in full at any time and that each and any special assessment may be paid without interest if payment in full by the first summer tax bill following the date of confirmation.

* * * * *

State of Michigan)
County of Jackson) ss
City of Jackson)

I, Andrea Muray, City Clerk in and for the City of Jackson, County and State aforesaid, do hereby certify that the foregoing is a true and complete copy of a resolution adopted by the Jackson City Council sitting as a Board of Review on the 11th day of July, 2023.

IN WITNESS WHEREOF, I have affixed my signature and the Seal of the City of Jackson, Michigan, on this 12th day of July 2023.

Andrea Muray, City Clerk

Population: Special Assessment District (3426)
Special Population Both Active and Inactive Parcels

Sp. District Heading	Parcel # Owner	Principal Admin Fee	Interest Penalty	Addtl Penlty Cert Fee	Total Installment	Prin Bal Payoff Int	Total Payoff
3426 ARNOLD, COOPER -	8-220900000 CASSA ROBERT E JR 2800 BLACKMAN RD JACKSON MI 49201	0.00 0.00	0.00		0.00	16,591.25 0.00	16,591.25
LOT 4 BLK 4 BINGHAM & RICE ADD							
3426 ARNOLD, COOPER -	8-221000000 KULIKOWSKI KENNETH 109 ARNOLD ST JACKSON MI 49202	0.00 0.00	0.00		0.00	10,750.00 0.00	10,750.00
LOT 5 BLK 4 BINGHAM & RICE ADD							
3426 ARNOLD, COOPER -	8-221100000 MITCHELL TERRANCE D ET AL 113 ARNOLD ST JACKSON MI 49202	0.00 0.00	0.00		0.00	9,325.00 0.00	9,325.00
LOT 8 BLK 4 BINGHAM & RICE ADD							
3426 ARNOLD, COOPER -	8-221200000 LEINDECKER JAMES & VICTORIA 119 ARNOLD ST JACKSON MI 49202	0.00 0.00	0.00		0.00	11,347.19 0.00	11,347.19
LOT 9 BLK 4 BINGHAM & RICE ADD							
3426 ARNOLD, COOPER -	8-221300000 EUBANKS JENNIFER & DONALD 121 ARNOLD ST JACKSON MI 49202	0.00 0.00	0.00		0.00	10,950.00 0.00	10,950.00
LOT 12 BLK 4 BINGHAM & RICE ADD							
3426 ARNOLD, COOPER -	8-221400000 FEY JEANIE M 238 MARVIN RD SMITHVILLE AR 72466	0.00 0.00	0.00		0.00	225.00 0.00	225.00
LOT 13 BLK 4 BINGHAM & RICE ADD							
3426 ARNOLD, COOPER -	8-221500000 GOLDEN BRITTANY L 129 ARNOLD ST JACKSON MI 49202	0.00 0.00	0.00		0.00	10,600.00 0.00	10,600.00
LOT 16 BLK 4 BINGHAM & RICE ADD							
3426 ARNOLD, COOPER -	8-221600000 ALLAN STEPHANIE 133 ARNOLD ST JACKSON MI 49202	0.00 0.00	0.00		0.00	8,125.00 0.00	8,125.00
LOT 17 BLK 4 BINGHAM & RICE ADD							

Special Assessment Roll for CITY OF JACKSON
Roll for Year 2023
Population: Special Assessment District (3426)
Special Population Both Active and Inactive Parcels

Sp. District Heading	Parcel # Owner	Principal Admin Fee	Interest Penalty	Addtl Penlty Cert Fee	Total Installment	Prin Bal Payoff Int	Total Payoff
3426 ARNOLD, COOPER -	8-221700000 GALAXY PROPERTIES 300 WOOLLEY DR MARSHALL MI 49068	0.00 0.00	0.00		0.00	7,875.00 0.00	7,875.00
LOT 20 BLK 4 BINGHAM & RICE ADD							
3426 ARNOLD, COOPER -	8-221800000 LAUER STEVEN 116 S MAIN ST CONCORD MI 49237	0.00 0.00	0.00		0.00	23,312.52 0.00	23,312.52
LOT 1 EX N 1 FT BLK 6 BINGHAM & RICE ADD							
3426 ARNOLD, COOPER -	8-222000000 LENNOX BRENDA J 110 ARNOLD ST JACKSON MI 49202	0.00 0.00	0.00		0.00	12,500.00 0.00	12,500.00
LOTS 3 & 4 BLK 6 BINGHAM & RICE ADD							
3426 ARNOLD, COOPER -	8-222100000 ALBERT RAY SR & ANNETTE 118 ARNOLD ST JACKSON MI 49202	0.00 0.00	0.00		0.00	11,347.19 0.00	11,347.19
LOT 5 BLK 6 BINGHAM & RICE ADD							
3426 ARNOLD, COOPER -	8-222200000 DAVIS STANLEY 122 ARNOLD ST JACKSON MI 49202	0.00 0.00	0.00		0.00	7,210.98 0.00	7,210.98
W 40.83 FT OF LOT 6 BLK 6 BINGHAM & RICE ADD							
3426 ARNOLD, COOPER -	8-222300000 WRIGHT KAYLA 124 ARNOLD ST JACKSON MI 49202	0.00 0.00	0.00		0.00	7,565.97 0.00	7,565.97
E 23.42 FT OF LOT 6 & W 19.42 FT OF LOT 7 BLK 6 BINGHAM & RICE ADD							
3426 ARNOLD, COOPER -	8-222400000 RICHARDS MICHAEL ET AL 126 ARNOLD ST JACKSON MI 49202	0.00 0.00	0.00		0.00	7,650.00 0.00	7,650.00
LOT 7 EX W 19.42 FT BLK 6 BINGHAM & RICE ADD							
3426 OLD, COOPER -	8-222500000 CROAD DUSTIN H 130 ARNOLD ST JACKSON MI 49202	0.00 0.00	0.00		0.00	11,347.19 0.00	11,347.19

LOT BLK6 BINGHAM & RICE ADD

Special Assessment Roll for CITY OF JACKSON
 Roll for Year 2023
 Population: Special Assessment District (3426)
 Special Population Both Active and Inactive Parcels

Sp. District Heading	Parcel # Owner	Principal Admin Fee	Interest Penalty	Addtl Penlty Cert Fee	Total Installment	Prin Bal Payoff Int	Total Payoff
3426	8-222600000	0.00	0.00		0.00	10,775.00	10,775.00
ARNOLD, COOPER -	SHARRER DAVID M & KELLY 136 ARNOLD ST JACKSON MI 49202	0.00				0.00	
2227	LOTS 9 & 10 BLK 6 BINGHAM & RICE ADD						
Total Parcels: 17		0.00	0.00		0.00	177,497.29	177,497.29
		0.00				0.00	

RESOLUTION

STREET RECONSTRUCTION AND WATER AND SEWER MAIN REPLACEMENT ON BIDDLE STREET

BY THE BOARD OF REVIEW:

WHEREAS, the Assessor, in accordance with the direction of the City Council, did prepare special assessments concerning street reconstruction and water and sewer main replacement on Biddle Street, from Greenwood Avenue to Williams Street which assessments were by him placed on Assessment Roll No. 3427 in the amount of \$33,487.50 and reported to the City Council as its meeting held on the 11th day of July, 2023; and

WHEREAS, notice has been duly given that the City Council and Assessor would sit as a Board of Review in the Council Chambers in the City of Jackson on Tuesday, July 11, 2023, at 6:30 p.m. to hear any and all objections and suggestions by interested parties to said special assessment as contained in said roll; and

WHEREAS, the matter of said review having come on to be heard and the City Council and Assessor sitting as a Board of Review having heard all suggestions and objections made thereto and having fully considered the same;

NOW, THEREFORE, BE IT RESOLVED, that each and all of the special assessments as contained in said roll are hereby confirmed and made valid liens against the property and valid claims against the owners thereof, and the City Clerk is hereby directed to make certificates of this determination and attach the same to said roll and to turn said roll over to the City Treasurer for collection; and

BE IT FURTHER RESOLVED that each and all of the special assessments contained in Roll No. 3427 shall be divided into 10 equal installments, the first of which shall be payable by the first summer tax bill following the date of the confirmation without interest charge; and the remaining installments, plus a 2.75% annual interest charge on each installment, shall be due annually each subsequent year at the same times with the same installments as the summer tax bill until each of the special assessments has been paid in full; provided, however, that in the event the City issues bonds in anticipation of special assessments, the unpaid balance of said special assessments shall, in accordance with Section 22-9 of the Jackson City Code of Ordinances, bear a rate of interest which may not be in excess of six percent (6%) per annum, or one percent (1%) above the average interest cost of said special assessment bonds.

BE IT FURTHER RESOLVED that the unpaid balance of any special assessment, including pro rata interest charges, may be paid in full at any time and that each and any special assessment may be paid without interest if payment in full by the first summer tax bill following the date of confirmation.

* * * * *

State of Michigan)
County of Jackson) ss
City of Jackson)

I, Andrea Muray, City Clerk in and for the City of Jackson, County and State aforesaid, do hereby certify that the foregoing is a true and complete copy of a resolution adopted by the Jackson City Council sitting as a Board of Review on the 11th day of July, 2023.

IN WITNESS WHEREOF, I have affixed my signature and the Seal of the City of Jackson, Michigan, on this 12th day of July 2023.

Andrea Muray, City Clerk

Special Assessment Roll for CITY OF JACKSON
Roll for Year 2023
Population: Special Assessment District (3427)
Special Population Both Active and Inactive Parcels

Sp. District Heading	Parcel # Owner	Principal Admin Fee	Interest Penalty	Addtl Penlty Cert Fee	Total Installment	Prin Bal Payoff Int	Total Payoff
3427 BIDDLE, GRNWD -	4-044500000 W NELSON JACK & ERNESTINE 712 S JACKSON ST JACKSON MI 49203	0.00 0.00	0.00		0.00	100.00 0.00	100.00
LAND COM AT INTERS OF N LN OF BIDDLE ST WITH W LN OF JACKSON ST TH N ON W LN OF JACKSON ST 36 FT TH W 66 FT TO A PRIVATE ALLEY TH ALG E LN OF SD ALLEY 36 FT TO N LN OF BIDDLE ST TH E ON N LN OF BIDDLE ST 66 FT TO BEG AN EXT OF VILLAGE OF JACKSONBURG KNOWN AS MOODY'S EXT B7S R1W (E OF GREENWOOD AVE)							
3427 BIDDLE, GRNWD -	4-044600000 W NELSON JACK & TINA 712 S JACKSON ST JACKSON MI 49203	0.00 0.00	0.00		0.00	100.00 0.00	100.00
W 34 FT OF E 108 FT OF LOT 4 & S 24 FT OF W 34 FT OF E 108 FT OF LOT 3 AN EXT OF VILLAGE OF JACKSONBURG KNOWN AS MOODY'S EXT OF B7S R1W (E OF GREENWOOD AVE)							
3427 BIDDLE, GRNWD -	4-044700000 W SINGH WARINDER 206 W BIDDLE ST JACKSON MI 49203	0.00 0.00	0.00		0.00	5,875.00 0.00	5,875.00
LAND COM AT PT OF INTERS OF N LN OF BIDDLE ST WITH W LN OF JACKSON ST TH W ALG N LN OF BIDDLE ST 108 FT TH W 53.25 FT TO A PRIVATE ALLEY TH N 6.35 FT TH NE'LY 6.45 FT TO A STAKE TH NE'LY ALONG PRIVATE ALLEY 87.8 FT TH E 8.85 FT TH S 90 FT TO POB. BEING PART OF LOTS 3, 4 & 5 AN EXT OF VILLAGE OF JACKSONBURG KNOWN AS MOODY'S EXT B7S R1W (E OF GREENWOOD AVE)							
3427 BIDDLE, GRNWD -	4-0450.1000 W SINGH PALWINDER 212 W BIDDLE ST JACKSON MI 49203	0.00 0.00	0.00		0.00	2,412.50 0.00	2,412.50
449 450 LAND COM AT INTERS OF ELY LN OF GREENWOOD AVE & N LN OF BIDDLE ST TH E ON N LN OF BIDDLE ST 93 FT TO A PRIVATE ALLEY TH N AT R/A TO BIDDLE ST 6.25 FT TH NELY ALG LN OF SD ALLEY 24 FT TH NWLY 76.67 FT TO ELY LN OF GREENWOOD AVE TH SWLY ON ELY LN OF SD AVE 75 FT TO BEG ALSO LAND COM AT IRON STAKE ON ELY LN OF GREENWOOD AVE 75 FT NLY FROM N LN OF BIDDLE ST TH NELY ON ELY LN OF SD AVE 42 FT TO AN IRON STAKE TH SELY 90 DEG 28' E 76.67 FT TH SWLY PARA WITH GREENWOOD AVE 42 FT TH NWLY 76.67 FT TO POB AN EXT OF VILLAGE OF JACKSONBURG KNOWN AS MOODY'S EXT B7S R1W (E OF GREENWOOD AVE)							
3427 BIDDLE, GRNWD -	4-049200000 W FITTON RANDALL 809 GREENWOOD AVE JACKSON MI 49203	0.00 0.00	0.00		0.00	300.00 0.00	300.00
N 32.5 FT OF LOTS 1 & 4 AN EXT OF VILLAGE OF JACKSONBURG KNOWN AS MOODY'S EXT B8S R1W (E OF GREENWOOD AVE)							
3427 BIDDLE, GRNWD -	4-050100000 W FITTON RANDALL 809 GREENWOOD AVE JACKSON MI 49203	0.00 0.00	0.00		0.00	2,575.00 0.00	2,575.00

05C
LOI AN EXT OF VILLAGE OF JACKSONBURG KNOWN AS MOODY'S EXT B8S R1W (E OF GREENWOOD AVE)

Special Assessment Roll for CITY OF JACKSON
Roll for Year 2023
Population: Special Assessment District (3427)
Special Population Both Active and Inactive Parcels

Sp. District Heading	Parcel # Owner	Principal Admin Fee	Interest Penalty	Addtl Penlty Cert Fee	Total Installment	Prin Bal Payoff Int	Total Payoff
3427 BIDDLE, GRNWD -	4-0509.1000 W ARNOLD MARK E & ALISA R 207 W BIDDLE ST JACKSON MI 49203	0.00 0.00	0.00		0.00	7,250.00 0.00	7,250.00
W 35 FT OF LOTS 9 & 10 EX S 26 FT OF LOT 9 AN EXT OF VILLAGE OF JACKSONBURG KNOWN AS MOODY'S EXT B8S R1W (E OF GREENWOOD AVE)							
3427 BIDDLE, GRNWD -	4-0509.3000 W ARNOLD MARK E & ALISA R 207 W BIDDLE ST JACKSON MI 49203	0.00 0.00	0.00		0.00	125.00 0.00	125.00
E 21 FT OF W 73.5 FT OF N 40 FT OF LOT 9 & E 21 FT OF W 56 FT OF LOT 10, ALSO N 61 FT OF E 17.5 FT OF W 73.5 FT OF LOT 10, AN EXT OF VILLAGE OF JACKSONBURG KNOWN AS MOODY'S EXT B8S R1W							
3427 BIDDLE, GRNWD -	4-0721.1000 W PARTNERSHIP PARK I LTD DIV HOUSING 4275 FIVE OAKS DR LANSING MI 48911	0.00 0.00	0.00		0.00	9,775.00 0.00	9,775.00
E 58.5 FT OF LOT 114 ASSESSOR'S SOUTH PLAT							
3427 BIDDLE, GRNWD -	4-0737.1000 W RODRIGUEZ VICTORIA L 136 W BIDDLE ST JACKSON MI 49203	0.00 0.00	0.00		0.00	100.00 0.00	100.00
W 42 FT OF LOT 131 ASSESSOR'S SOUTH PLAT							
3427 BIDDLE, GRNWD -	4-073800000 W RODRIGUEZ VICTORIA L 136 W BIDDLE ST JACKSON MI 49203	0.00 0.00	0.00		0.00	4,875.00 0.00	4,875.00
COM AT A PT ON N LN OF BIDDLE ST 98.5 FT E OF E LN OF JACKSON ST TH N 66 FT TH E TO NE COR OF LOT 132 TH S TO N LN OF BIDDLE ST TH W TO BEG BEING LOT 132 & PART OF LOT 133 ASSESSOR'S SOUTH PLAT							
Total Parcels: 11		0.00 0.00	0.00		0.00	33,487.50 0.00	33,487.50

RESOLUTION
STREET RECONSTRUCTION AND WATER AND SEWER MAIN REPLACEMENT ON BURR STREET

BY THE BOARD OF REVIEW:

WHEREAS, the Assessor, in accordance with the direction of the City Council, did prepare special assessments concerning street reconstruction and water and sewer main replacement on Burr Street, from Cooper to State Street which assessments were by him placed on Assessment Roll No. 3428 in the amount of \$173,365.06 and reported to the City Council as its meeting held on the 11th day of July, 2023; and

WHEREAS, notice has been duly given that the City Council and Assessor would sit as a Board of Review in the Council Chambers in the City of Jackson on Tuesday, July 11, 2023, at 6:30 p.m. to hear any and all objections and suggestions by interested parties to said special assessment as contained in said roll; and

WHEREAS, the matter of said review having come on to be heard and the City Council and Assessor sitting as a Board of Review having heard all suggestions and objections made thereto and having fully considered the same;

NOW, THEREFORE, BE IT RESOLVED, that each and all of the special assessments as contained in said roll are hereby confirmed and made valid liens against the property and valid claims against the owners thereof, and the City Clerk is hereby directed to make certificates of this determination and attach the same to said roll and to turn said roll over to the City Treasurer for collection; and

BE IT FURTHER RESOLVED that each and all of the special assessments contained in Roll No. 3428 shall be divided into 10 equal installments, the first of which shall be payable by the first summer tax bill following the date of the confirmation without interest charge; and the remaining installments, plus a 2.75% annual interest charge on each installment, shall be due annually each subsequent year at the same times with the same installments as the summer tax bill until each of the special assessments has been paid in full; provided, however, that in the event the City issues bonds in anticipation of special assessments, the unpaid balance of said special assessments shall, in accordance with Section 22-9 of the Jackson City Code of Ordinances, bear a rate of interest which may not be in excess of six percent (6%) per annum, or one percent (1%) above the average interest cost of said special assessment bonds.

BE IT FURTHER RESOLVED that the unpaid balance of any special assessment, including pro rata interest charges, may be paid in full at any time and that each and any special assessment may be paid without interest if payment in full by the first summer tax bill following the date of confirmation.

* * * * *

State of Michigan)
County of Jackson) ss
City of Jackson)

I, Andrea Muray, City Clerk in and for the City of Jackson, County and State aforesaid, do hereby certify that the foregoing is a true and complete copy of a resolution adopted by the Jackson City Council sitting as a Board of Review on the 11th day of July, 2023.

IN WITNESS WHEREOF, I have affixed my signature and the Seal of the City of Jackson, Michigan, on this 12th day of July 2023.

Andrea Muray, City Clerk

Roll for Year 2023
Population: Special Assessment District (3428)
Special Population Both Active and Inactive Parcels

Sp. District Heading	Parcel # Owner	Principal Admin Fee	Interest Penalty	Addtl Penlty Cert Fee	Total Installment	Prin Bal Payoff Int	Total Payoff
3428 BURR, COOPER -	7-022100000 ST RUSSELL CHRISTOPHER 801 BURR ST JACKSON MI 49201	0.00 0.00	0.00		0.00	2,282.36 0.00	2,282.36
N 50.75 FT OF W 62 FT OF LOT 2 BLK 3 AN EXT OF THE VILLAGE OF JACKSONBURGH ON E SIDE OF GRAND RIVER KNOWN AS FORD'S EASTERN EXT							
3428 BURR, COOPER -	7-0222.1000 ST CROWNLIN PROPERTIES LLC 1894 SUNCREST DR GRASS LAKE MI 49240	0.00 0.00	0.00		0.00	5,675.00 0.00	5,675.00
E 1/2 OF LOT 3 BLK 3 AN EXT OF THE VILLAGE OF JACKSONBURGH ON THE EAST SIDE OF GRAND RIVER KNOWN AS FORD'S EASTERN EXT							
3428 BURR, COOPER -	7-022200000 ST CROWNLIN PROPERTIES LLC 1894 SUNCREST DR GRASS LAKE MI 49240	0.00 0.00	0.00		0.00	6,750.00 0.00	6,750.00
W 1/2 OF LOT 3 & E 4 FT OF N 50.75 FT OF LOT 2 BLK 3 AN EXT OF THE VILLAGE OF JACKSONBURGH ON THE EAST SIDE OF GRAND RIVER KNOWN AS FORD'S EASTERN EXT							
3428 BURR, COOPER -	7-022700000 ST CANNON JAMES D ESTATE 5061 PAGE AVENUE JACKSON MI 49201	0.00 0.00	0.00		0.00	6,450.00 0.00	6,450.00
E 57.75 FT OF N 1/2 OF LOT 7 ALSO A TRIANGULAR STRIP OF LAND ADJ ABOVE LAND ON THE E TO STATE ST BLK 3 AN EXT OF THE VILLAGE OF JACKSONBURGH ON THE EAST SIDE OF GRAND RIVER KNOWN AS FORD'S EASTERN EXT							
3428 BURR, COOPER -	7-0231.0100 ST WHEELDON MICHAEL T 409 N VAN DORN ST JACKSON MI 49201	0.00 0.00	0.00		0.00	6,850.00 0.00	6,850.00
LOTS 1 & 3 AND THE S 1/2 OF LOT 2 BLK 4 AN EXT OF THE VILLAGE OF JACKSONBURGH ON E SIDE OF GRAND RIVER KNOWN AS FORD'S EASTERN EXT COMBINED ON 01/23/2023 FROM 7-023100000, 7-023000000, 7-023300000, 7-023400000							
3428 BURR, COOPER -	7-023200000 ST BIG FISH HOLDINGS LLC 30 N GOULD ST STE R SHERIDAN WY 82801	0.00 0.00	0.00		0.00	9,220.20 0.00	9,220.20
N 1/2 OF LOT 2 BLK 4 AN EXT OF THE VILLAGE OF JACKSONBURGH ON E SIDE OF GRAND RIVER KNOWN AS FORD'S EASTERN EXT							
3428 R, COOPER -	7-023600000 ST PASCARELLA DAVID A PO BOX 680596 ORLANDO FL 32868	0.00 0.00	0.00		0.00	200.00 0.00	200.00

N 1 OF LOT 6 BLK 4 AN EXT OF THE VILLAGE OF JACKSONBURGH ON E SIDE OF GRAND RIVER KNOWN AS FORD'S
EAS N EXT

Roll for Year 2023
Population: Special Assessment District (3428)
Special Population Both Active and Inactive Parcels

Sp. District Heading	Parcel # Owner	Principal Admin Fee	Interest Penalty	Addtl Penlty Cert Fee	Total Installment	Prin Bal Payoff Int	Total Payoff
3428	7-023700000	0.00	0.00		0.00	200.00	200.00
BURR, COOPER - ST	PASCARELLA DAVID A	0.00				0.00	
	PO BOX 680596						
	ORLANDO FL 32868						

N 1/2 OF LOT 7 BLK 4 AN EXT OF THE VILLAGE OF JACKSONBURGH ON E SIDE OF GRAND RIVER KNOWN AS FORD'S EASTERN EXT

3428	7-0243.2000	0.00	0.00		0.00	10,125.00	10,125.00
BURR, COOPER - ST	VROMAN LEE & KIMBERLY R	0.00				0.00	
	605 BURR ST						
	JACKSON MI 49201						

0242, 0243

LOT 6 AND THE N 93 FT OF LOTS 2 & 3 BLK 5 AN EXT OF THE VILLAGE OF JACKSONBURGH ON THE EAST SIDE OF GRAND RIVER KNOWN AS FORD'S EASTERN EXT
COMBINED ON 08/30/2016 FROM 7-0243.1000, 7-024700000;

3428	7-024800000	0.00	0.00		0.00	6,700.00	6,700.00
BURR, COOPER - ST	BOWSER ROBERTA J ET AL ESTATE	0.00				0.00	
	414 N VAN DORN ST						
	JACKSON MI 49201						

LOT 7 EX S 88 FT BLK 5 AN EXT OF THE VILLAGE OF JACKSONBURGH ON E SIDE OF GRAND RIVER KNOWN AS FORD'S EASTERN EXT

3428	7-026400000	0.00	0.00		0.00	6,825.00	6,825.00
BURR, COOPER - ST	H & H RENTAL LLC	0.00				0.00	
	2222 W GRAND RIVER AVE STE A						
	OKEMOS MI 48864						

0270

W 24 FT OF N 64 FT OF LOT 6 & N 64 FT OF LOT 7 BLK 6 AN EXT OF THE VILLAGE OF JACKSONBURGH ON THE EAST SIDE OF GRAND RIVER KNOWN AS FORD'S EASTERN EXT

3428	7-065200000	0.00	0.00		0.00	5,850.00	5,850.00
BURR, COOPER - ST	ARMSTRONG SHIRLEY LE	0.00				0.00	
	610 BURR ST						
	JACKSON MI 49201						

E 1/2 OF LOT 5 BLK 7 FORD'S NORTH ADD

3428	7-065300000	0.00	0.00		0.00	150.00	150.00
BURR, COOPER - ST	ARMSTRONG SHIRLEY LE	0.00				0.00	
	610 BURR ST						
	JACKSON MI 49201						

W 1/2 OF LOT 5 BLK 7 FORD'S NORTH ADD

3428	7-065400000	0.00	0.00		0.00	7,200.00	7,200.00
R, COOPER - ST	BURDICK CHERYL	0.00				0.00	
	606 BURR ST						
	JACKSON MI 49201						

S 8 T OF E 56 FT OF LOT 4 BLK 7 FORD'S NORTH ADD

Roll for Year 2023
Population: Special Assessment District (3428)
Special Population Both Active and Inactive Parcels

Sp. District Heading	Parcel # Owner	Principal Admin Fee	Interest Penalty	Addtl Penlty Cert Fee	Total Installment	Prin Bal Payoff Int	Total Payoff
3428	7-065600000 BURR, COOPER - ST SANTANA MARIA J LE 702 BURR ST JACKSON MI 49201	0.00 0.00	0.00		0.00	8,925.00 0.00	8,925.00
LAND COM AT A PT ON NLY LN OF HAMLIN ST AT SE COR OF BLK 7 TH N ON ELY LN OF SD BLK TO NE COR OF LOT 12 SD BLK TH WLY 78 FT TH SLY TO A PT ON NLY LN OF HAMLIN ST 54 FT WLY OF SE COR OF LOT 12 BLK 7 TH ELY ON NLY LN OF HAMLIN ST 54 FT TO BEG BEING LOT 12 & PART OF LOT 9 BLK 7 FORD'S NORTH ADD							
3428	7-065700000 BURR, COOPER - ST SANTANA MARIA J LE 2824 LASALLE GARDENS LANSING MI 48912	0.00 0.00	0.00		0.00	175.00 0.00	175.00
BEG AT SW COR OF LOT 9 BLK 7 TH ELY ALG NLY LN OF BURR ST 33.3 FT TH NWLY TO PT ON NLY LN OF LOT 9 SD PT BEING 43.9 FT NELY FROM NW CORNER OF LOT 9 TH SWLY TO NW COR OF LOT 9 TH SELY TO BEG BLK 7 FORD'S NORTH ADD							
3428	7-065900000 BURR, COOPER - ST THORNE ROBBROY M & DEBRA A 514 BURR ST JACKSON MI 49201	0.00 0.00	0.00		0.00	12,575.00 0.00	12,575.00
0660.1A S 99 FT OF LOT 1 & E 4 FT OF S 1/2 OF LOT 4 BLK 8 FORD'S NORTH ADD							
3428	7-0660.1000 BURR, COOPER - ST BELTRAN BETTY & JOSE ESTATE 510 BURR ST JACKSON MI 49201	0.00 0.00	0.00		0.00	5,375.00 0.00	5,375.00
0661 W 48 FT OF E 52 FT OF S 1/2 OF LOT 4 & S 1/2 OF N 1/2 OF LOT 4 BLK 8 FORD'S NORTH ADD							
3428	7-0661.1000 BURR, COOPER - ST MALISZEWSKI BRIAN 8124 INDEPENDENCE RD STERLING HEIGHTS MI 48313	0.00 0.00	0.00		0.00	75.00 0.00	75.00
WLY 14 FT OF S 1/2 OF LOT 4 BLK 8 FORD'S NORTH ADD							
3428	7-066400000 BURR, COOPER - ST MALISZEWSKI BRIAN 8124 INDEPENDENCE RD STERLING HEIGHTS MI 48313	0.00 0.00	0.00		0.00	20,075.00 0.00	20,075.00
S 48 FT OF LOT 5 BLK 8 FORD'S NORTH ADD							
3428	7-0700.1000 BURR, COOPER - ST FLACK DONALD L SR & SHERLENE A TRUS 10404 MONTROSE DR MANCELONA MI 49659	0.00 0.00	0.00		0.00	200.00 0.00	200.00

COM INTERS OF NLY LN OF BURR ST WITH E LN OF HARRIS ST BEING SW COR OF LOT 12 HARRIS ADD TH N 105 FT E LN OF HARRIS ST TH E 62.33 FT PARA WITH N LN OF LOT 12 TH SLY 88.4 FT TO NLY LN OF BURR ST 68.5 FT ELY FROM POB OF THIS DESC TH WLY 68.50 FT TO BEG BEING PART OF LOTS 11 & 12 HARRIS ADD

Roll for Year 2023
Population: Special Assessment District (3428)
Special Population Both Active and Inactive Parcels

Sp. District Heading	Parcel # Owner	Principal Admin Fee	Interest Penalty	Addtl Penlty Cert Fee	Total Installment	Prin Bal Payoff Int	Total Payoff
3428 BURR, COOPER - ST	7-070000000 LAMMERS JEFFRY L 1995 KIBBY RD APT 1 JACKSON MI 49203	0.00 0.00	0.00		0.00	9,600.00 0.00	9,600.00
COM AT INTERS OF NLY LN OF BURR ST WITH ELY LN OF HARRIS ST TH ELY ALG NLY LN OF BURR ST 68.5 FT FOR POB OF THIS DESC TH NWLY 88.4 FT TO A PT 62.33 FT E OF E LN OF HARRIS ST TH W 62.33 FT OF E LN OF HARRIS ST TH N 13 FT TH E 127.05 FT TH S 85.8 FT TO NLY LN OF BURR ST TH WLY TO BEG BEING PART OF LOTS 11 & 12 HARRIS ADD							
3428 BURR, COOPER - ST	7-071500000 CHRISTIAN ASSEMBLY CHURCH 506 HARRIS ST JACKSON MI 49201	0.00 0.00	0.00		0.00	200.00 0.00	200.00
S 1/2 OF LOT 23 HARRIS ADD							
3428 BURR, COOPER - ST	7-071600000 CHRISTIAN ASSEMBLY CHURCH 506 HARRIS ST JACKSON MI 49201	0.00 0.00	0.00		0.00	7,162.50 0.00	7,162.50
S 11 FT OF N 1/2 OF LOT 24 & ALL OF S 1/2 OF LOT 24 HARRIS ADD							
3428 BURR, COOPER - ST	7-073000000 BENN CHRIS N & DEBORA 808 BURR ST JACKSON MI 49201	0.00 0.00	0.00		0.00	8,625.00 0.00	8,625.00
BEG AT SE CORNER OF LOT 11 HARRIS ADD TH N 151.8 FT ALG ELY LN OF SD ADD TH NELY 55 FT PARA TO NLY LN OF BURR ST TH SLY 151.8 FT PARA TO ELY LN OF HARRIS ADD TO A PT ON NLY LN OF BURR ST TH SWLY TO BEG NE 1/4 SW 1/4 SEC 35 T2S R1W							
3428 BURR, COOPER - ST	7-073100000 DAINES JOHN 814 BURR ST JACKSON MI 49201	0.00 0.00	0.00		0.00	6,475.00 0.00	6,475.00
BEG AT A PT ON N LN OF BURR ST 242 FT W OF W LN OF STATE ST TH N TO SW CORNER OF LOT 6 MRS E FREY'S ADD TH NELY 55 FT ALG SD ADD TH SLY TO A PT ON NLY LN OF BURR ST SD PT BEING 187 FT W OF W LN OF STATE ST TH SWLY TO BEG NE 1/4 SW 1/4 SEC 35 T2S R1W							
3428 BURR, COOPER - ST	7-073200000 NASTALLY AMBER 816 BURR ST JACKSON MI 49201	0.00 0.00	0.00		0.00	8,925.00 0.00	8,925.00
LAND COM AT INTERS OF NLY LN OF BURR ST WITH W LN OF STATE ST TH WLY ON NLY LN OF BURR ST 132 FT FOR POB OF THIS DESC TH WLY ON NLY LN OF BURR ST 55 FT TH N PARA WITH W LN OF STATE ST TO S LN OF MRS E FREY'S ADD TH ELY ALG SLY LN OF SD ADD 55 FT TH S PARA WITH W LN OF STATE ST 264 FT TO NLY LN OF HAM ST & BEG NE 1/4 SW 1/4 SEC 35 T2S R1W							

Special Assessment Roll for CITY OF JACKSON
Roll for Year 2023
Population: Special Assessment District (3428)
Special Population Both Active and Inactive Parcels

Sp. District Heading	Parcel # Owner	Principal Admin Fee	Interest Penalty	Addtl Penlty Cert Fee	Total Installment	Prin Bal Payoff Int	Total Payoff
3428	7-073400000	0.00	0.00		0.00	10,500.00	10,500.00
BURR, COOPER - ST	GALINDO ERIC	0.00				0.00	
	820 BURR ST						
	JACKSON MI 49201						
LAND COM AT INTERS OF N LN OF BURR ST (FORMERLY HAMLIN ST) WITH W LN OF STATE ST TH N 4 RDS TH WLY PARA WITH N LN OF BURR ST (FORMERLY HAMLIN ST) 8 RDS TH S 4 RDS TO N LN OF BURR ST (FORMERLY HAMLIN ST) TH ELY ON N LN OF BURR ST (FORMERLY HAMLIN ST) 8 RDS TO BEG NE 1/4 SW 1/4 SEC 35 T2S R1W							
Total Parcels: 28		0.00	0.00		0.00	173,365.06	173,365.06
		0.00				0.00	

RESOLUTION
STREET RECONSTRUCTION AND WATER AND SEWER MAIN REPLACEMENT ON BURR STREET

BY THE BOARD OF REVIEW:

WHEREAS, the Assessor, in accordance with the direction of the City Council, did prepare special assessments concerning street reconstruction and water and sewer main replacement on Burr Street, from State Street to Waterloo Street which assessments were by him placed on Assessment Roll No. 3429 in the amount of \$63,450.00 and reported to the City Council as its meeting held on the 11th day of July, 2023; and

WHEREAS, notice has been duly given that the City Council and Assessor would sit as a Board of Review in the Council Chambers in the City of Jackson on Tuesday, July 11, 2023, at 6:30 p.m. to hear any and all objections and suggestions by interested parties to said special assessment as contained in said roll; and

WHEREAS, the matter of said review having come on to be heard and the City Council and Assessor sitting as a Board of Review having heard all suggestions and objections made thereto and having fully considered the same;

NOW, THEREFORE, BE IT RESOLVED, that each and all of the special assessments as contained in said roll are hereby confirmed and made valid liens against the property and valid claims against the owners thereof, and the City Clerk is hereby directed to make certificates of this determination and attach the same to said roll and to turn said roll over to the City Treasurer for collection; and

BE IT FURTHER RESOLVED that each and all of the special assessments contained in Roll No. 3429 shall be divided into 10 equal installments, the first of which shall be payable by the first summer tax bill following the date of the confirmation without interest charge; and the remaining installments, plus a 2.75% annual interest charge on each installment, shall be due annually each subsequent year at the same times with the same installments as the summer tax bill until each of the special assessments has been paid in full; provided, however, that in the event the City issues bonds in anticipation of special assessments, the unpaid balance of said special assessments shall, in accordance with Section 22-9 of the Jackson City Code of Ordinances, bear a rate of interest which may not be in excess of six percent (6%) per annum, or one percent (1%) above the average interest cost of said special assessment bonds.

BE IT FURTHER RESOLVED that the unpaid balance of any special assessment, including pro rata interest charges, may be paid in full at any time and that each and any special assessment may be paid without interest if payment in full by the first summer tax bill following the date of confirmation.

* * * * *

State of Michigan)
County of Jackson) ss
City of Jackson)

I, Andrea Muray, City Clerk in and for the City of Jackson, County and State aforesaid, do hereby certify that the foregoing is a true and complete copy of a resolution adopted by the Jackson City Council sitting as a Board of Review on the 11th day of July, 2023.

IN WITNESS WHEREOF, I have affixed my
signature and the Seal of the City of Jackson, Michigan, on
this 12th day of July 2023.

Andrea Muray, City Clerk

Population: Special Assessment District (3429)
Special Population Both Active and Inactive Parcels

Sp. District Heading	Parcel # Owner	Principal Admin Fee	Interest Penalty	Addtl Penlty Cert Fee	Total Installment	Prin Bal Payoff Int	Total Payoff
3429 BURR, STATE - WAT	7-0209.2000 GROVE MARTIN W 413 N STATE ST JACKSON MI 49201	0.00 0.00	0.00		0.00	150.00 0.00	150.00
E 44 FT OF N 1/2 OF LOT 3 EX THE W 26 FT OF THE N 38 FT THEREOF, BLK 2 AN EXT OF THE VILLAGE OF JACKSONBURGH ON THE E SIDE OF GRAND RIVER KNOWN AS FORD'S EASTERN EXT (BOUNDARY ADJUSTMENT PARCELS 7-0209 & 7-0209.2 FOR 2021)							
3429 BURR, STATE - WAT	7-020900000 BARTOSZEK MICHAEL D 415 N STATE ST JACKSON MI 49201	0.00 0.00	0.00		0.00	5,900.00 0.00	5,900.00
N 38 FT OF N 1/2 OF LOTS 2 & 3 EX E 18 FT OF LOT 3 BLK 2 AN EXT OF VILLAGE OF JACKSONBURGH ON EAST SIDE OF GRAND RIVER KNOWN AS FORD'S EASTERN EXT (BOUNDARY ADJUSTMENT PARCELS 7-0209 & 7-0209.2 FOR 2021)							
3429 BURR, STATE - WAT	7-021000000 MIDSTATE INVESTMENTS INC 4064 LANSING AVE JACKSON MI 49202	0.00 0.00	0.00		0.00	7,250.00 0.00	7,250.00
LOT 6 BLK 2 AN EXT OF THE VILLAGE OF JACKSONBURGH ON E SIDE OF GRAND RIVER KNOWN AS FORD'S EASTERN EXT							
3429 BURR, STATE - WAT	7-021100000 HOWARD RICHARD & CRYSTAL 913 BURR ST JACKSON MI 49201	0.00 0.00	0.00		0.00	9,700.00 0.00	9,700.00
LOT 7 BLK 2 AN EXT OF VILLAGE OF JACKSONBURGH ON E SIDE OF GRAND RIVER KNOWN AS FORD'S EASTERN EXT							
3429 BURR, STATE - WAT	7-021200000 ALSAFFAR YOUNIS & EVELYN 406 N WATERLOO AVE JACKSON MI 49201	0.00 0.00	0.00		0.00	275.00 0.00	275.00
LOT 10 & AS MUCH OF LOT 11 AS LIES W OF WATERLOO AVE BLK 2 AN EXT OF THE VILLAGE OF JACKSONBURGH ON E SIDE OF GRAND RIVER KNOWN AS FORD'S EASTERN EXT							
3429 BURR, STATE - WAT	7-074300000 CIDERHOUSE LLC 268 S PLATT ST MILAN MI 48160	0.00 0.00	0.00		0.00	7,350.00 0.00	7,350.00
LAND COM AT INTERS OF E LN OF STATE ST WITH NLY LN OF HAMLIN ST TH ELY ON NLY LN OF HAMLIN ST 87 FT TH N 51 FT TH WLY 85 FT TO E LN OF STATE ST TH S 62.25 FT TO BEG NE 1/4 SW 1/4 SEC 35 T2S R1W							
3429 R, STATE - WAT	7-074400000 SERAFIN RONALD J & VICTORIA E 906 BURR ST JACKSON MI 49201	0.00 0.00	0.00		0.00	7,625.00 0.00	7,625.00

LAND COM AT A PT ON NLY LN OF HAMLIN ST 87 FT ELY OF E LN OF STATE ST TH NLY 165.85 FT TH E 52.5 FT TH WLY 53 FT TO NLY LN OF HAMLIN ST TH WLY 50 FT TO BEG NE 1/4 SW 1/4 SEC 35 T2S R1W

Special Assessment Roll for CITY OF JACKSON
 Roll for Year 2023
 Population: Special Assessment District (3429)
 Special Population Both Active and Inactive Parcels

Sp. District Heading	Parcel # Owner	Principal Admin Fee	Interest Penalty	Addtl Penlty Cert Fee	Total Installment	Prin Bal Payoff Int	Total Payoff
3429 BURR, STATE - WAT	7-074500000 BURR WILLIAM C & CATHERINE B 13045 WEST 525 SOUTH COLUMBUS IN 47201	0.00 0.00	0.00		0.00	9,550.00 0.00	9,550.00
LAND COM AT A PT ON NLY LN OF HAMLIN ST 137 FT ELY OF E LN OF STATE ST TH N 220 FT TH E 66 FT TH S 204.5 FT TH WLY ON NLY LN OF HAMLIN ST 69 FT TO BEG NE 1/4 SW 1/4 SEC 35 T2S R1W							
3429 BURR, STATE - WAT	7-074600000 MORAN THOMAS J IV & TINA M 914 BURR ST JACKSON MI 49201	0.00 0.00	0.00		0.00	6,800.00 0.00	6,800.00
LAND COM AT A PT ON NLY LN OF HAMLIN ST 68.4 FT WLY OF W LN OF WATERLOO AVE TH N 176.8 FT TH W 45.72 FT TH S 188.5 FT TO NLY LN OF HAMLIN ST TH ELY 51.2 FT TO BEG NE 1/4 SW 1/4 SEC 35 T2S R1W							
3429 BURR, STATE - WAT	7-074700000 CHASE MATTHEW H 916 BURR ST JACKSON MI 49201	0.00 0.00	0.00		0.00	8,850.00 0.00	8,850.00
LAND COM AT INTERS OF W LN OF WATERLOO AVE WITH NLY LN OF HAMLIN ST TH N 81.75 FT TH W 66 FT TH S 99 FT TO NLY LN OF HAMLIN ST TH ELY 68.4 FT TO BEG NE 1/4 SW 1/4 SEC 35 T2S R1W							
Total Parcels: 10		0.00 0.00	0.00		0.00	63,450.00 0.00	63,450.00

RESOLUTION
STREET RECONSTRUCTION AND WATER AND SEWER MAIN REPLACEMENT ON DEYO STREET

BY THE BOARD OF REVIEW:

WHEREAS, the Assessor, in accordance with the direction of the City Council, did prepare special assessments concerning street reconstruction and water and sewer main replacement on Deyo Street, from Elm Street to Gorham Street which assessments were by him placed on Assessment Roll No. 3430 in the amount of \$205,486.56 and reported to the City Council as its meeting held on the 11th day of July, 2023; and

WHEREAS, notice has been duly given that the City Council and Assessor would sit as a Board of Review in the Council Chambers in the City of Jackson on Tuesday, July 11, 2023, at 6:30 p.m. to hear any and all objections and suggestions by interested parties to said special assessment as contained in said roll; and

WHEREAS, the matter of said review having come on to be heard and the City Council and Assessor sitting as a Board of Review having heard all suggestions and objections made thereto and having fully considered the same;

NOW, THEREFORE, BE IT RESOLVED, that each and all of the special assessments as contained in said roll are hereby confirmed and made valid liens against the property and valid claims against the owners thereof, and the City Clerk is hereby directed to make certificates of this determination and attach the same to said roll and to turn said roll over to the City Treasurer for collection; and

BE IT FURTHER RESOLVED that each and all of the special assessments contained in Roll No. 3430 shall be divided into 10 equal installments, the first of which shall be payable by the first summer tax bill following the date of the confirmation without interest charge; and the remaining installments, plus a 2.75% annual interest charge on each installment, shall be due annually each subsequent year at the same times with the same installments as the summer tax bill until each of the special assessments has been paid in full; provided, however, that in the event the City issues bonds in anticipation of special assessments, the unpaid balance of said special assessments shall, in accordance with Section 22-9 of the Jackson City Code of Ordinances, bear a rate of interest which may not be in excess of six percent (6%) per annum, or one percent (1%) above the average interest cost of said special assessment bonds.

BE IT FURTHER RESOLVED that the unpaid balance of any special assessment, including pro rata interest charges, may be paid in full at any time and that each and any special assessment may be paid without interest if payment in full by the first summer tax bill following the date of confirmation.

* * * * *

State of Michigan)
County of Jackson) ss
City of Jackson)

I, Andrea Muray, City Clerk in and for the City of Jackson, County and State aforesaid, do hereby certify that the foregoing is a true and complete copy of a resolution adopted by the Jackson City Council sitting as a Board of Review on the 11th day of July, 2023.

IN WITNESS WHEREOF, I have affixed my signature and the Seal of the City of Jackson, Michigan, on this 12th day of July 2023.

Andrea Muray, City Clerk

Special Assessment Roll for CITY OF JACKSON
Roll for Year 2023
Population: Special Assessment District (3430)
Special Population Both Active and Inactive Parcels

Sp. District Heading	Parcel # Owner	Principal Admin Fee	Interest Penalty	Addtl Penlty Cert Fee	Total Installment	Prin Bal Payoff Int	Total Payoff
3430 DEYO, ELM - GORHA	6-101100000 CHMIEL SHARON L 313 S ELM AVE JACKSON MI 49203	0.00 0.00	0.00		0.00	7,175.00 0.00	7,175.00
LOT 4 EX E 40 FT BLK 31 EAST ADD							
3430 DEYO, ELM - GORHA	6-101200000 GUAJARDO BEVERLY ET AL 1606 DEYO ST JACKSON MI 49203	0.00 0.00	0.00		0.00	5,700.00 0.00	5,700.00
1014 E 40 FT OF LOT 4 & ALL OF LOT 6 BLK 31 EAST ADD							
3430 DEYO, ELM - GORHA	6-101600000 HALL HOME SOLUTIONS LLC 12749 BROOKS MEADOW DR BROOKLYN MI 49230	0.00 0.00	0.00		0.00	7,150.00 0.00	7,150.00
LOT 8 BLK 31 EAST ADD							
3430 DEYO, ELM - GORHA	6-101800000 DEWALT KAYLA E & PATRICK T JR 1619 CHAPIN ST JACKSON MI 49203	0.00 0.00	0.00		0.00	350.00 0.00	350.00
1020 LOT 10 & W 43.34 FT OF LOT 12 BLK 31 EAST ADD							
3430 DEYO, ELM - GORHA	6-102100000 HOWELL MICHAEL L & LAURIE 1704 DEYO ST JACKSON MI 49203	0.00 0.00	0.00		0.00	6,950.00 0.00	6,950.00
W 30 FT OF LOT 14 & E 22 FT OF LOT 12 BLK 31 EAST ADD							
3430 DEYO, ELM - GORHA	6-102200000 NELSON GARY R SR & CHERRY ET AL 1706 DEYO ST JACKSON MI 49203	0.00 0.00	0.00		0.00	5,099.20 0.00	5,099.20
E 35.34 FT OF LOT 14 BLK 31 EAST ADD							
3430 DEYO, ELM - GORHA	6-102400000 COLLINS JOEY S 1708 DEYO ST JACKSON MI 49203	0.00 0.00	0.00		0.00	7,800.00 0.00	7,800.00
LOT 16 BLK 31 EAST ADD							
0 O, ELM - GORHA	6-102600000 PEEK CARROLL D & FERN I 1712 DEYO ST JACKSON MI 49203	0.00 0.00	0.00		0.00	9,427.90 0.00	9,427.90
LOT 16 BLK 31 EAST ADD							

Special Assessment Roll for CITY OF JACKSON
Roll for Year 2023
Population: Special Assessment District (3430)
Special Population Both Active and Inactive Parcels

Sp. District Heading	Parcel # Owner	Principal Admin Fee	Interest Penalty	Addtl Penlty Cert Fee	Total Installment	Prin Bal Payoff Int	Total Payoff
3430 DEYO, ELM - GORHA	6-102900000 GRIEVE MICHAEL 1717 DEYO ST JACKSON MI 49203	0.00 0.00	0.00		0.00	9,250.00 0.00	9,250.00
LOT 2 BLK 32 EAST ADD							
3430 DEYO, ELM - GORHA	6-103100000 PARKER ELIZABETH J 1806 DEYO ST JACKSON MI 49203	0.00 0.00	0.00		0.00	8,900.00 0.00	8,900.00
LOT 4 BLK 32 EAST ADD							
3430 DEYO, ELM - GORHA	6-103300000 NELSON STEVEN J 1808 DEYO ST JACKSON MI 49203	0.00 0.00	0.00		0.00	5,750.00 0.00	5,750.00
LOT 6 BLK 32 EAST ADD							
3430 DEYO, ELM - GORHA	6-103500000 BULL DANIEL L 1812 DEYO ST JACKSON MI 49203	0.00 0.00	0.00		0.00	6,200.00 0.00	6,200.00
LOT 8 BLK 32 EAST ADD							
3430 DEYO, ELM - GORHA	6-103800000 JOSEPH MICHAEL J 627 W MONROE ST JACKSON MI 49202	0.00 0.00	0.00		0.00	8,475.00 0.00	8,475.00
LOT 10 BLK 32 EAST ADD							
3430 DEYO, ELM - GORHA	6-104000000 CLAYBORN ANNE M 1900 DEYO ST JACKSON MI 49203	0.00 0.00	0.00		0.00	5,275.00 0.00	5,275.00
LOT 12 BLK 32 EAST ADD							
3430 DEYO, ELM - GORHA	6-1043.1000 MANNERS DANIEL 414 S GORHAM ST JACKSON MI 49203	0.00 0.00	0.00		0.00	175.00 0.00	175.00
1043 LOT 14 EX N 68 FT BLK 32 EAST ADD							
0 0, ELM - GORHA	6-104400000 MANNERS DANIEL 712 IRVING ST JACKSON MI 49202	0.00 0.00	0.00		0.00	7,825.00 0.00	7,825.00

LOT 26 BLK 32 EAST ADD

Special Assessment Roll for CITY OF JACKSON
Roll for Year 2023
Population: Special Assessment District (3430)
Special Population Both Active and Inactive Parcels

Sp. District Heading	Parcel # Owner	Principal Admin Fee	Interest Penalty	Addtl Penlty Cert Fee	Total Installment	Prin Bal Payoff Int	Total Payoff
3430	6-109100000 DEYO, ELM - GORHA UCTUM LUTFIYE YESIM P O BOX 323 SOUTHFILED MI 48037	0.00 0.00	0.00		0.00	7,525.00 0.00	7,525.00
LOT 3 BLK 37 EAST ADD							
3430	6-1092.A000 DEYO, ELM - GORHA COLEMAN JOSEPH 9105 HARRISON ST LIVONIA MI 48150	0.00 0.00	0.00		0.00	9,332.67 0.00	9,332.67
LOT 5 BLK 37 EAST ADD							
3430	6-109400000 DEYO, ELM - GORHA CARNES SHARON L 1815 DEYO ST JACKSON MI 49203	0.00 0.00	0.00		0.00	8,000.00 0.00	8,000.00
LOT 7 BLK 37 EAST ADD							
3430	6-109900000 DEYO, ELM - GORHA EUTYCHUS PROPERTIES LLC 500 FORD ST APT B8 PLYMOUTH MI 48170	0.00 0.00	0.00		0.00	4,666.33 0.00	4,666.33
E 1/2 OF LOT 11 BLK 37 EAST ADD							
3430	6-110000000 DEYO, ELM - GORHA STUBBLEFIELD LEO JR 1901 DEYO ST JACKSON MI 49203	0.00 0.00	0.00		0.00	4,666.33 0.00	4,666.33
W 1/2 OF LOT 11 BLK 37 EAST ADD							
3430	6-110200000 DEYO, ELM - GORHA MYERS ADAM L & TONI A 1905 DEYO ST JACKSON MI 49203	0.00 0.00	0.00		0.00	6,975.00 0.00	6,975.00
LOT 13 BLK 37 EAST ADD							
3430	6-111100000 DEYO, ELM - GORHA SODERBECK ERIC J ET AL 502 S GORHAM ST JACKSON MI 49203	0.00 0.00	0.00		0.00	6,850.00 0.00	6,850.00
LOT 18 BLK 37 EAST ADD							
3430	6-111200000 O, ELM - GORHA RIDER CATHLINE ET AL 401 S ELM AVE JACKSON MI 49203	0.00 0.00	0.00		0.00	7,225.00 0.00	7,225.00

LOT EX E 50 FT BLK 38 EAST ADD

Special Assessment Roll for CITY OF JACKSON
Roll for Year 2023
Population: Special Assessment District (3430)
Special Population Both Active and Inactive Parcels

Sp. District Heading	Parcel # Owner	Principal Admin Fee	Interest Penalty	Addtl Penlty Cert Fee	Total Installment	Prin Bal Payoff Int	Total Payoff
3430 DEYO, ELM - GORHA	6-111300000 PATTON ERIC 1607 DEYO ST JACKSON MI 49203	0.00 0.00	0.00		0.00	7,214.50 0.00	7,214.50
E 50 FT OF LOT 1 BLK 38 EAST ADD							
3430 DEYO, ELM - GORHA	6-111900000 PATTON ANGELENE (HARRIS) 1611 DEYO ST JACKSON MI 49203	0.00 0.00	0.00		0.00	7,350.00 0.00	7,350.00
LOT 5 BLK 38 EAST ADD							
3430 DEYO, ELM - GORHA	6-112500000 THOMPSON DONNA J 1703 DEYO ST JACKSON MI 49203	0.00 0.00	0.00		0.00	6,253.52 0.00	6,253.52
E 21.67 FT OF LOT 9 & W 22 FT OF LOT 11 BLK 38 EAST ADD							
3430 DEYO, ELM - GORHA	6-112700000 ROCK ANDREA ET AL 1705 DEYO ST JACKSON MI 49203	0.00 0.00	0.00		0.00	5,125.00 0.00	5,125.00
E 43.34 FT OF LOT 11 BLK 38 EAST ADD							
3430 DEYO, ELM - GORHA	6-112900000 ANDREWS SALLY J ET AL 1705 DEYO ST JACKSON MI 49203	0.00 0.00	0.00		0.00	175.00 0.00	175.00
W 39.2 FT OF LOT 13 BLK 38 EAST ADD							
3430 DEYO, ELM - GORHA	6-113200000 ROCKWELL BRIAN P O BOX 1778 JACKSON MI 49204	0.00 0.00	0.00		0.00	5,771.60 0.00	5,771.60
E 26.1 FT OF LOT 13 & W 13.87 FT OF LOT 15 BLK 38 EAST ADDITION							
3430 DEYO, ELM - GORHA	6-113300000 GRIEVE MICHAEL A 1717 DEYO ST JACKSON MI 49203	0.00 0.00	0.00		0.00	5,771.60 0.00	5,771.60
W 40 FT OF E 51.47 FT OF N 85 FT OF LOT 15 BLK 38 EAST ADDITION							
3430 O, ELM - GORHA	6-113500000 GRIEVE MICHAEL A 1717 DEYO ST JACKSON MI 49203	0.00 0.00	0.00		0.00	11,082.91 0.00	11,082.91
N 7 T OF LOT 17 & E 11.47 FT OF N 85 FT OF LOT 15 BLK 38 EAST ADDITION							
al Parcels: 32		0.00 0.00	0.00		0.00	205,486.56 0.00	205,486.56

RESOLUTION
STREET RECONSTRUCTION AND WATER MAIN REPLACEMENT ON DWIGHT STREET

BY THE BOARD OF REVIEW:

WHEREAS, the Assessor, in accordance with the direction of the City Council, did prepare special assessments concerning street reconstruction and water main replacement on Dwight Street, from Chapin to Tyson Street which assessments were by him placed on Assessment Roll No. 3431 in the amount of \$115,883.86 and reported to the City Council as its meeting held on the 11th day of July, 2023; and

WHEREAS, notice has been duly given that the City Council and Assessor would sit as a Board of Review in the Council Chambers in the City of Jackson on Tuesday, July 11, 2023, at 6:30 p.m. to hear any and all objections and suggestions by interested parties to said special assessment as contained in said roll; and

WHEREAS, the matter of said review having come on to be heard and the City Council and Assessor sitting as a Board of Review having heard all suggestions and objections made thereto and having fully considered the same;

NOW, THEREFORE, BE IT RESOLVED, that each and all of the special assessments as contained in said roll are hereby confirmed and made valid liens against the property and valid claims against the owners thereof, and the City Clerk is hereby directed to make certificates of this determination and attach the same to said roll and to turn said roll over to the City Treasurer for collection; and

BE IT FURTHER RESOLVED that each and all of the special assessments contained in Roll No. 3431 shall be divided into 10 equal installments, the first of which shall be payable by the first summer tax bill following the date of the confirmation without interest charge; and the remaining installments, plus a 2.75% annual interest charge on each installment, shall be due annually each subsequent year at the same times with the same installments as the summer tax bill until each of the special assessments has been paid in full; provided, however, that in the event the City issues bonds in anticipation of special assessments, the unpaid balance of said special assessments shall, in accordance with Section 22-9 of the Jackson City Code of Ordinances, bear a rate of interest which may not be in excess of six percent (6%) per annum, or one percent (1%) above the average interest cost of said special assessment bonds.

BE IT FURTHER RESOLVED that the unpaid balance of any special assessment, including pro rata interest charges, may be paid in full at any time and that each and any special assessment may be paid without interest if payment in full by the first summer tax bill following the date of confirmation.

* * * * *

State of Michigan)
County of Jackson) ss
City of Jackson)

I, Andrea Muray, City Clerk in and for the City of Jackson, County and State aforesaid, do hereby certify that the foregoing is a true and complete copy of a resolution adopted by the Jackson City Council sitting as a Board of Review on the 11th day of July, 2023.

IN WITNESS WHEREOF, I have affixed my
signature and the Seal of the City of Jackson, Michigan, on
this 12th day of July 2023.

Andrea Muray, City Clerk

Special Assessment Roll for CITY OF JACKSON
Roll for Year 2023
Population: Special Assessment District (3431)
Special Population Both Active and Inactive Parcels

Sp. District Heading	Parcel # Owner	Principal Admin Fee	Interest Penalty	Addtl Penlty Cert Fee	Total Installment	Prin Bal Payoff Int	Total Payoff
3431 DWIGHT, CHAPIN -	6-089200000 AUSTIN ROBERT & BARBARA 2013 TYSON ST JACKSON MI 49203	0.00 0.00	0.00		0.00	8,700.00 0.00	8,700.00
LOTS 3 & 4 BLK 25 EAST ADD NO 5							
3431 DWIGHT, CHAPIN -	6-089300000 COHEN BENJAMIN C ET AL 208 S DWIGHT ST JACKSON MI 49203	0.00 0.00	0.00		0.00	6,896.77 0.00	6,896.77
N 43 FT OF LOT 5 BLK 25 EAST ADD NO 5							
3431 DWIGHT, CHAPIN -	6-089700000 MISKOVIC JOHN F & KERRY 212 S DWIGHT ST JACKSON MI 49203	0.00 0.00	0.00		0.00	7,050.00 0.00	7,050.00
0897.1 N 44 FT OF S 45 FT OF LOT 8 BLK 25 EAST ADD NO 5							
3431 DWIGHT, CHAPIN -	6-089800000 THOMAS JOHN ET AL 2326 PIONEER DR JACKSON MI 49201	0.00 0.00	0.00		0.00	2,950.00 0.00	2,950.00
S 1 FT OF LOT 8 & N 32 FT OF LOT 9 BLK 25 EAST ADDITION NO 5							
3431 DWIGHT, CHAPIN -	6-089900000 MARSHALL MATTHEW S & PATRICIA 102 DORIS DR CAMDEN TN 38320	0.00 0.00	0.00		0.00	5,292.87 0.00	5,292.87
N 33 FT OF S 34 FT OF LOT 9 BLK 25 EAST ADD NO 5							
3431 DWIGHT, CHAPIN -	6-090300000 NOWLAN JASON 218 S DWIGHT ST JACKSON MI 49203	0.00 0.00	0.00		0.00	6,350.00 0.00	6,350.00
S 1 FT OF LOT 9 & N 44 FT OF LOT 12 BLK 25 EAST ADDITION NO 5							
3431 DWIGHT, CHAPIN -	6-0905.0100 NOWLAN BEVERLY D 222 S DWIGHT ST JACKSON MI 49203	0.00 0.00	0.00		0.00	6,900.00 0.00	6,900.00
LOT 13 & S 22 FT OF LOT 12, BLK 25 EAST ADD NO 5 COMBINED ON 01/30/2022 FROM 6-090500000, 6-090400000							
1 GHT, CHAPIN -	6-091000000 BURROWS DAVID 224 S DWIGHT ST JACKSON MI 49203	0.00 0.00	0.00		0.00	6,175.01 0.00	6,175.01
N 3 /2 FT OF LOTS 17 & 18 BLK 25 E ADD NO 5							

Special Assessment Roll for CITY OF JACKSON
Roll for Year 2023
Population: Special Assessment District (3431)
Special Population Both Active and Inactive Parcels

Sp. District Heading	Parcel # Owner	Principal Admin Fee	Interest Penalty	Addtl Penlty Cert Fee	Total Installment	Prin Bal Payoff Int	Total Payoff
3431 DWIGHT, CHAPIN -	6-091200000 JONES AJAYLAH 2014 CHAPIN ST JACKSON MI 49203	0.00 0.00	0.00		0.00	7,125.00 0.00	7,125.00
E 52 FT OF S 95 FT OF LOT 18 BLK 25 E ADD NO 5							
3431 DWIGHT, CHAPIN -	6-091300000 HARKNESS LESLIE M 207 S DWIGHT ST JACKSON MI 49203	0.00 0.00	0.00		0.00	6,415.60 0.00	6,415.60
S 40 FT OF LOT 1 & S 32 FT OF LOT 2 BLK 26 E ADD NO 5							
3431 DWIGHT, CHAPIN -	6-091400000 TIMPERLEY NATHAN W & JENNIFER 2103 TYSON ST JACKSON MI 49203	0.00 0.00	0.00		0.00	7,100.00 0.00	7,100.00
LOT 1 EX S 40 FT BLK 26 EAST ADD NO 5							
3431 DWIGHT, CHAPIN -	6-092000000 HILAND AMY B ET AL 209 S DWIGHT ST JACKSON MI 49203	0.00 0.00	0.00		0.00	5,292.87 0.00	5,292.87
N 1/2 OF LOT 7 BLK 26 EAST ADD NO 5							
3431 DWIGHT, CHAPIN -	6-092100000 PEREZ MARIA E 211 S DWIGHT ST JACKSON MI 49203	0.00 0.00	0.00		0.00	5,292.87 0.00	5,292.87
S 1/2 OF LOT 7 BLK 26 EAST ADD NO 5							
3431 DWIGHT, CHAPIN -	6-092200000 MISKOVIC JOHN F JR & KERRY L 212 S DWIGHT ST JACKSON MI 49203	0.00 0.00	0.00		0.00	5,292.87 0.00	5,292.87
N 1/2 OF LOT 8 BLK 26 EAST ADD NO 5							
3431 DWIGHT, CHAPIN -	6-092800000 STRICKLER ENRIQUETA 219 S DWIGHT ST JACKSON MI 49203	0.00 0.00	0.00		0.00	7,225.00 0.00	7,225.00
LOT 11 EX S 14.5 FT BLK 26 EAST ADD NO 5							
3431 GHT, CHAPIN -	6-092900000 MATTEI CAROL A ET AL 221 S DWIGHT ST JACKSON MI 49203	0.00 0.00	0.00		0.00	6,950.00 0.00	6,950.00
S 1 /2 FT OF LOT 11 & N 36 1/2 FT OF OT 12 BLK 26 EAST ADD NO 5							

Special Assessment Roll for CITY OF JACKSON
Roll for Year 2023
Population: Special Assessment District (3431)
Special Population Both Active and Inactive Parcels

Sp. District Heading	Parcel # Owner	Principal Admin Fee	Interest Penalty	Addtl Penlty Cert Fee	Total Installment	Prin Bal Payoff Int	Total Payoff
3431 DWIGHT, CHAPIN -	6-093000000 GOMEZ CHRISTOPHER & ASHLEY 223 S DWIGHT ST JACKSON MI 49203	0.00 0.00	0.00		0.00	7,075.00 0.00	7,075.00
S 29 1/2 FT OF LOT 12 & N 16 1/2 FT OF OT 15 BLK 26 EAST ADD NO 5							
3431 DWIGHT, CHAPIN -	6-093400000 BONNYMEDE PROPERTIES LLC 6231 MOON LAKE RD JACKSON MI 49201	0.00 0.00	0.00		0.00	7,450.00 0.00	7,450.00
S 3 RDS OF LOT 15 BLK 26 EAST ADD NO 5							
3431 DWIGHT, CHAPIN -	6-093500000 PENMARK INC 1000 W NORTH AVE CHICAGO IL 60622	0.00 0.00	0.00		0.00	200.00 0.00	200.00
S 95 FT OF LOT 16 BLK 26 EAST ADD NO 5							
3431 DWIGHT, CHAPIN -	6-093600000 PENMARK INC 1000 W NORTH AVE CHICAGO IL 60622	0.00 0.00	0.00		0.00	150.00 0.00	150.00
N 38.5 FT OF LOTS 16 & 17 BLK 26 EAST ADD #5							
Total Parcels: 20		0.00 0.00	0.00		0.00	115,883.86 0.00	115,883.86

RESOLUTION
STREET RECONSTRUCTION AND WATER MAIN REPLACEMENT ON GRINNELL STREET

BY THE BOARD OF REVIEW:

WHEREAS, the Assessor, in accordance with the direction of the City Council, did prepare special assessments concerning street reconstruction and water main replacement on Grinnell Street, from Norfolk to Wildwood which assessments were by him placed on Assessment Roll No. 3435 in the amount of \$185,424.24 and reported to the City Council as its meeting held on the 11th day of July, 2023; and

WHEREAS, notice has been duly given that the City Council and Assessor would sit as a Board of Review in the Council Chambers in the City of Jackson on Tuesday, July 11, 2023, at 6:30 p.m. to hear any and all objections and suggestions by interested parties to said special assessment as contained in said roll; and

WHEREAS, the matter of said review having come on to be heard and the City Council and Assessor sitting as a Board of Review having heard all suggestions and objections made thereto and having fully considered the same;

NOW, THEREFORE, BE IT RESOLVED, that each and all of the special assessments as contained in said roll are hereby confirmed and made valid liens against the property and valid claims against the owners thereof, and the City Clerk is hereby directed to make certificates of this determination and attach the same to said roll and to turn said roll over to the City Treasurer for collection; and

BE IT FURTHER RESOLVED that each and all of the special assessments contained in Roll No. 3435 shall be divided into 10 equal installments, the first of which shall be payable by the first summer tax bill following the date of the confirmation without interest charge; and the remaining installments, plus a 2.75% annual interest charge on each installment, shall be due annually each subsequent year at the same times with the same installments as the summer tax bill until each of the special assessments has been paid in full; provided, however, that in the event the City issues bonds in anticipation of special assessments, the unpaid balance of said special assessments shall, in accordance with Section 22-9 of the Jackson City Code of Ordinances, bear a rate of interest which may not be in excess of six percent (6%) per annum, or one percent (1%) above the average interest cost of said special assessment bonds.

BE IT FURTHER RESOLVED that the unpaid balance of any special assessment, including pro rata interest charges, may be paid in full at any time and that each and any special assessment may be paid without interest if payment in full by the first summer tax bill following the date of confirmation.

* * * * *

State of Michigan)
County of Jackson) ss
City of Jackson)

I, Andrea Muray, City Clerk in and for the City of Jackson, County and State aforesaid, do hereby certify that the foregoing is a true and complete copy of a resolution adopted by the Jackson City Council sitting as a Board of Review on the 11th day of July, 2023.

IN WITNESS WHEREOF, I have affixed my signature and the Seal of the City of Jackson, Michigan, on this 12th day of July 2023.

Andrea Muray, City Clerk

Population: Special Assessment District (3435)
Special Population Both Active and Inactive Parcels

Sp. District Heading	Parcel # Owner	Principal Admin Fee	Interest Penalty	Addtl Penlty Cert Fee	Total Installment	Prin Bal Payoff Int	Total Payoff
3435 GRINNELL, NORFLK	2-016900000 ROBINSON LEE A 815 WILDWOOD AVE JACKSON MI 49202	0.00 0.00	0.00		0.00	14,838.40 0.00	14,838.40
W 13.87 FT OF LOT 3 EX THE S 85 FT ALSO LOT 4 EX THE S 85 FT THEREOF BLK 1 WITHINGTON'S ADD							
3435 GRINNELL, NORFLK	2-017000000 MAYNARD PERRY & KRISTIE 225 N GRINNELL ST JACKSON MI 49202	0.00 0.00	0.00		0.00	6,584.54 0.00	6,584.54
N 35.5 FT OF S 85 FT OF LOT 4 ALSO N 35.5 FT OF S 85 FT OF W 33 FT OF LOT 3 BLK 1 WITHINGTON'S ADD							
3435 GRINNELL, NORFLK	2-017100000 LLY REALTY LLC P O BOX 6182 JACKSON MI 49204	0.00 0.00	0.00		0.00	6,584.54 0.00	6,584.54
N 35.5 FT OF S 49.5 FT OF LOT 4 ALSO N 35.5 FT OF S 49.5 FT OF W 33 FT OF LOT 3 BLK 1 WITHINGTON'S ADD							
3435 GRINNELL, NORFLK	2-017200000 GRINNELL MID-MI HEALTH CENTERS LLC 214 N WEST AVE JACKSON MI 49201	0.00 0.00	0.00		0.00	425.00 0.00	425.00
S 14 FT OF LOTS 3 & 4 & N 26 FT OF LOT 5 BLK 1 WITHINGTON'S ADD							
3435 GRINNELL, NORFLK	2-017300000 GRINNELL MID-MI HEALTH CENTERS LLC 214 N WEST AVE JACKSON MI 49201	0.00 0.00	0.00		0.00	425.00 0.00	425.00
S 40 FT OF LOT 5 BLK 1 WITHINGTON'S ADD							
3435 GRINNELL, NORFLK	2-017400000 GRINNELL MID-MI HEALTH CENTERS LLC 214 N WEST AVE JACKSON MI 49201	0.00 0.00	0.00		0.00	12,241.68 0.00	12,241.68
LOT 6 BLK 1 WITHINGTON'S ADD							
3435 GRINNELL, NORFLK	2-0179.0200 GRINNELL MID-MI HEALTH CENTERS LLC 214 N WEST AVE JACKSON MI 49201	0.00 0.00	0.00		0.00	61,208.40 0.00	61,208.40
LOTS 8, 9, 10, 11, 12, 13, 14, 15, 16 & 17 BLK 1 WITHINGTON'S ADD							
COM ATION ON 01/24/2012 FROM 2-0179.1000, 2-018400000, 2-018700000; 2-017600000, 2-017700000, 2-01800000, 2-018200000							
COM ED ON 02/12/2015 FROM 2-0179.2000, 2-017800000, 2-018000000, 2-018100000							
COM ED ON 02/10/2020 FROM 2-0179.3000, 2-018300000, 2-018500000, 2-018600000							
SPL COMBINED ON 01/19/2021 FROM 2-0179.0100, 2-017500000							

Population: Special Assessment District (3435)
Special Population Both Active and Inactive Parcels

Sp. District Heading	Parcel # Owner	Principal Admin Fee	Interest Penalty	Addtl Penlty Cert Fee	Total Installment	Prin Bal Payoff Int	Total Payoff
3435 GRINNELL, NORFLK	2-018800000 GRINNELL MID-MI HEALTH CENTERS LLC 214 N WEST AVE JACKSON MI 49201	0.00 0.00	0.00		0.00	8,325.00 0.00	8,325.00
LOTS 1 & 2 BLK 2 WITHINGTON'S ADD							
3435 GRINNELL, NORFLK	2-019400000 BROWN DEBRA D 226 N GRINNELL ST JACKSON MI 49202	0.00 0.00	0.00		0.00	8,025.00 0.00	8,025.00
LOT 7 BLK 2 WITHINGTON'S ADD							
3435 GRINNELL, NORFLK	2-020000000 REED WILLIE J SR & ROSE M 222 N GRINNELL ST JACKSON MI 49202	0.00 0.00	0.00		0.00	11,825.00 0.00	11,825.00
0197 LOTS 9 & 11 BLK 2 WITHINGTON'S ADD							
3435 GRINNELL, NORFLK	2-020200000 MILLER LILLI B ET AL 216 N GRINNELL ST JACKSON MI 49202	0.00 0.00	0.00		0.00	9,525.00 0.00	9,525.00
LOT 13 BLK 2 WITHINGTON'S ADD							
3435 GRINNELL, NORFLK	2-020400000 LARSON JOSEPH D 214 N GRINNELL ST JACKSON MI 49202	0.00 0.00	0.00		0.00	10,875.00 0.00	10,875.00
LOT 15 BLK 2 WITHINGTON'S ADD							
3435 GRINNELL, NORFLK	2-020600000 DACK MICHELLE D 210 N GRINNELL ST JACKSON MI 49202	0.00 0.00	0.00		0.00	11,200.00 0.00	11,200.00
LOT 17 BLK 2 WITHINGTON'S ADD							
3435 GRINNELL, NORFLK	2-020800000 MILLMAC PROPERTIES LLC 205 S SANDSTONE RD JACKSON MI 49201	0.00 0.00	0.00		0.00	12,241.68 0.00	12,241.68
LOT 19 BLK 2 WITHINGTON'S ADD							
5 NNELL, NORFLK	2-021300000 SMITH CONROY 202 N GRINNELL ST JACKSON MI 49202	0.00 0.00	0.00		0.00	11,100.00 0.00	11,100.00

E 4 S OF LOT 21 BLK 2 WITHINGTON'S ADD

Special Assessment Roll for CITY OF JACKSON
Roll for Year 2023
Population: Special Assessment District (3435)
Special Population Both Active and Inactive Parcels

Sp. District Heading	Parcel # Owner	Principal Admin Fee	Interest Penalty	Addtl Penlty Cert Fee	Total Installment	Prin Bal Payoff Int	Total Payoff
Total Parcels: 15		0.00 0.00	0.00		0.00	185,424.24 0.00	185,424.24

RESOLUTION
STREET RECONSTRUCTION AND WATER MAIN REPLACEMENT ON MCBRIDE STREET

BY THE BOARD OF REVIEW:

WHEREAS, the Assessor, in accordance with the direction of the City Council, did prepare special assessments concerning street reconstruction and water main replacement on McBride Street, from Fourth to First Street which assessments were by him placed on Assessment Roll No. 3436 in the amount of \$285,670.35 and reported to the City Council as its meeting held on the 11th day of July, 2023; and

WHEREAS, notice has been duly given that the City Council and Assessor would sit as a Board of Review in the Council Chambers in the City of Jackson on Tuesday, July 11, 2023, at 6:30 p.m. to hear any and all objections and suggestions by interested parties to said special assessment as contained in said roll; and

WHEREAS, the matter of said review having come on to be heard and the City Council and Assessor sitting as a Board of Review having heard all suggestions and objections made thereto and having fully considered the same;

NOW, THEREFORE, BE IT RESOLVED, that each and all of the special assessments as contained in said roll are hereby confirmed and made valid liens against the property and valid claims against the owners thereof, and the City Clerk is hereby directed to make certificates of this determination and attach the same to said roll and to turn said roll over to the City Treasurer for collection; and

BE IT FURTHER RESOLVED that each and all of the special assessments contained in Roll No. 3436 shall be divided into 10 equal installments, the first of which shall be payable by the first summer tax bill following the date of the confirmation without interest charge; and the remaining installments, plus a 2.75% annual interest charge on each installment, shall be due annually each subsequent year at the same times with the same installments as the summer tax bill until each of the special assessments has been paid in full; provided, however, that in the event the City issues bonds in anticipation of special assessments, the unpaid balance of said special assessments shall, in accordance with Section 22-9 of the Jackson City Code of Ordinances, bear a rate of interest which may not be in excess of six percent (6%) per annum, or one percent (1%) above the average interest cost of said special assessment bonds.

BE IT FURTHER RESOLVED that the unpaid balance of any special assessment, including pro rata interest charges, may be paid in full at any time and that each and any special assessment may be paid without interest if payment in full by the first summer tax bill following the date of confirmation.

* * * * *

State of Michigan)
County of Jackson) ss
City of Jackson)

I, Andrea Muray, City Clerk in and for the City of Jackson, County and State aforesaid, do hereby certify that the foregoing is a true and complete copy of a resolution adopted by the Jackson City Council sitting as a Board of Review on the 11th day of July, 2023.

IN WITNESS WHEREOF, I have affixed my signature and the Seal of the City of Jackson, Michigan, on this 12th day of July 2023.

Andrea Muray, City Clerk

Special Assessment Roll for CITY OF JACKSON
Roll for Year 2023
Population: Special Assessment District (3436)
Special Population Both Active and Inactive Parcels

Sp. District Heading	Parcel # Owner	Principal Admin Fee	Interest Penalty	Addtl Penlty Cert Fee	Total Installment	Prin Bal Payoff Int	Total Payoff
3436 MCBRIDE, FOURTH	3-206900000 - KOPP KENYON 612 MCBRIDE ST JACKSON MI 49203	0.00 0.00	0.00		0.00	1,000.00 0.00	1,000.00
W 44 FT OF LOTS 1 & 2 BLK 11 HARWOOD'S ADD							
3436 MCBRIDE, FOURTH	3-2070.0100 - COVERT SCOTT 610 MCBRIDE ST JACKSON MI 49203	0.00 0.00	0.00		0.00	8,130.32 0.00	8,130.32
E 44 FT OF W 88 FT OF LOTS 1 & 2 BLK 11 HARWOOD'S ADD, ALSO S 46 OF LOT 1 BLK 3 EATON WEBSTER & HARWOOD'S ADD COMBINED ON 01/28/2020 FROM 3-207000000, 3-198100000							
3436 MCBRIDE, FOURTH	3-207100000 - JOHNSON JAMIE L 608 MCBRIDE ST JACKSON MI 49203	0.00 0.00	0.00		0.00	8,130.32 0.00	8,130.32
E 44 FT OF LOTS 1 & 2 BLK 11 HARWOOD'S ADD							
3436 MCBRIDE, FOURTH	3-207200000 - KEENA JENNIFER E 606 MCBRIDE ST JACKSON MI 49203	0.00 0.00	0.00		0.00	8,130.32 0.00	8,130.32
W 44 FT OF LOT 3 BLK 11 HARWOOD'S ADD							
3436 MCBRIDE, FOURTH	3-207300000 - SUPER KATHERINE E 604 MCBRIDE ST JACKSON MI 49203	0.00 0.00	0.00		0.00	8,130.32 0.00	8,130.32
W 22 FT OF LOT 4 & E 22 FT OF LOT 3 BLK 11 HARWOOD'S ADD							
3436 MCBRIDE, FOURTH	3-207500000 - KELLER DARREN & REPP KARLIE A 516 MCBRIDE ST JACKSON MI 49203	0.00 0.00	0.00		0.00	10,347.68 0.00	10,347.68
W 56 FT OF LOT 6 BLK 11 HARWOOD'S ADD							
3436 MCBRIDE, FOURTH	3-207600000 - MILLER MARCIA J 512 MCBRIDE ST JACKSON MI 49203	0.00 0.00	0.00		0.00	9,978.12 0.00	9,978.12
E 10 FT OF LOT 6 & W 44 FT OF LOT 7 BLK 11 HARWOOD'S ADD							
6 RIDE, FOURTH	3-207700000 - SPREEMAN RUSSELL 510 MCBRIDE ST JACKSON MI 49203	0.00 0.00	0.00		0.00	8,130.32 0.00	8,130.32
E 2 FT OF LOT 7 & W 22 FT OF LOT 8 BLK 11 HARWOOD'S ADD							

Special Assessment Roll for CITY OF JACKSON
Roll for Year 2023
Population: Special Assessment District (3436)
Special Population Both Active and Inactive Parcels

Sp. District Heading	Parcel # Owner	Principal Admin Fee	Interest Penalty	Addtl Penlty Cert Fee	Total Installment	Prin Bal Payoff Int	Total Payoff
3436 MCBRIDE, FOURTH	3-207800000 - LYMAN ERIK T & SARAH L 508 MCBRIDE ST JACKSON MI 49203	0.00 0.00	0.00		0.00	8,130.32 0.00	8,130.32
E 44 FT OF LOT 8 BLK 11 HARWOOD'S ADD							
3436 MCBRIDE, FOURTH	3-207900000 - GLOVER SARAH M 506 MCBRIDE ST JACKSON MI 49203	0.00 0.00	0.00		0.00	12,195.48 0.00	12,195.48
LOT 9 BLK 11 HARWOOD'S ADD							
3436 MCBRIDE, FOURTH	3-208000000 - CARTER DAVID A ET AL 502 MCBRIDE ST JACKSON MI 49203	0.00 0.00	0.00		0.00	8,130.32 0.00	8,130.32
W 44 FT OF LOT 10 BLK 11 HARWOOD'S ADD							
3436 MCBRIDE, FOURTH	3-208100000 - TYSON CHAD M & LEAH M 500 MCBRIDE ST JACKSON MI 49203	0.00 0.00	0.00		0.00	8,130.32 0.00	8,130.32
E 22 FT OF LOT 10 & W 22 FT OF LOT 11 BLK 11 HARWOOD'S ADD							
3436 MCBRIDE, FOURTH	3-208200000 - KARAZIM JOHN J 412 MCBRIDE ST JACKSON MI 49203	0.00 0.00	0.00		0.00	8,130.32 0.00	8,130.32
E 44 FT OF LOT 11 BLK 11 HARWOOD'S ADD							
3436 MCBRIDE, FOURTH	3-208300000 - ANDERSON VERNICE M & FRANKLIN 410 MCBRIDE ST JACKSON MI 49203	0.00 0.00	0.00		0.00	12,195.48 0.00	12,195.48
LOT 12 BLK 11 HARWOOD'S ADD							
3436 MCBRIDE, FOURTH	3-208500000 - MOORE SCOTT E III ET AL 1028 FIRST ST JACKSON MI 49203	0.00 0.00	0.00		0.00	15,000.00 0.00	15,000.00
LOT 14 BLK 11 HARWOOD'S ADD							
3436 RIDE, FOURTH	3-208600000 - SMITH MAX C JR & SUSAN L 611 MCBRIDE ST JACKSON MI 49203	0.00 0.00	0.00		0.00	9,239.00 0.00	9,239.00
W 5 T OF LOTS 1 & 2 BLK 12 HARWOOD'S ADD							

Special Assessment Roll for CITY OF JACKSON
Roll for Year 2023
Population: Special Assessment District (3436)
Special Population Both Active and Inactive Parcels

Sp. District Heading	Parcel # Owner	Principal Admin Fee	Interest Penalty	Addtl Penlty Cert Fee	Total Installment	Prin Bal Payoff Int	Total Payoff
3436 MCBRIDE, FOURTH	3-208700000 - OLLILA ANDREA L 7416 MAGGIE DR ANTOICH TN 37013	0.00 0.00	0.00		0.00	9,054.22 0.00	9,054.22
E 49 FT OF W 6 RDS OF LOTS 1 & 2 BLK 12 HARWOOD'S ADD							
3436 MCBRIDE, FOURTH	3-208800000 - WALL TYLER 607 MC BRIDE ST JACKSON MI 49203	0.00 0.00	0.00		0.00	9,054.22 0.00	9,054.22
E 33 FT OF LOTS 1 & 2 & W 16 FT OF LOT 5 BLK 12 HARWOOD'S ADD							
3436 MCBRIDE, FOURTH	3-209200000 - HOOVER CHRISTOPHER D & SUSAN M LE 758 UNION ST JACKSON MI 49203	0.00 0.00	0.00		0.00	9,239.00 0.00	9,239.00
E 50 FT OF LOT 5 BLK 12 HARWOOD'S ADD							
3436 MCBRIDE, FOURTH	3-209500000 - SLONE SCOTT & BONNIE ET AL 601 MCBRIDE ST JACKSON MI 49203	0.00 0.00	0.00		0.00	12,195.48 0.00	12,195.48
N 72 FT OF LOT 7 BLK 12 HARWOOD'S ADD							
3436 MCBRIDE, FOURTH	3-209800000 - ANGSTMAN ETHAN A ET AL 519 MCBRIDE ST JACKSON MI 49203	0.00 0.00	0.00		0.00	12,195.48 0.00	12,195.48
LOT 11 BLK 12 HARWOOD'S ADD							
3436 MCBRIDE, FOURTH	3-210000000 - GAUSS MAXWELL J 515 MCBRIDE ST JACKSON MI 49203	0.00 0.00	0.00		0.00	12,195.48 0.00	12,195.48
LOT 13 BLK 12 HARWOOD'S ADD							
3436 MCBRIDE, FOURTH	3-210300000 - SEAMAN GEORGE 509 MCBRIDE ST JACKSON MI 49203	0.00 0.00	0.00		0.00	12,195.48 0.00	12,195.48
LOT 15 BLK 12 HARWOOD'S ADD							
3436 RIDE, FOURTH	3-210500000 - HYDE WILLIAM T JR 2105 GANTON DR JACKSON MI 49203	0.00 0.00	0.00		0.00	10,925.00 0.00	10,925.00
LOT 17 BLK 12 HARWOOD'S ADD							

LOT 17 BLK 12 HARWOOD'S ADD

Special Assessment Roll for CITY OF JACKSON
Roll for Year 2023
Population: Special Assessment District (3436)
Special Population Both Active and Inactive Parcels

Sp. District Heading	Parcel # Owner	Principal Admin Fee	Interest Penalty	Addtl Penlty Cert Fee	Total Installment	Prin Bal Payoff Int	Total Payoff
3436 MCBRIDE, FOURTH	3-210700000 - JOHNSON BRITNEY L 503 MCBRIDE ST JACKSON MI 49203	0.00 0.00	0.00		0.00	12,195.48 0.00	12,195.48
LOT 19 BLK 12 HARWOOD'S ADD							
3436 MCBRIDE, FOURTH	3-211000000 - GOFF DAVID R 413 MCBRIDE ST JACKSON MI 49203	0.00 0.00	0.00		0.00	12,195.48 0.00	12,195.48
LOT 21 BLK 12 HARWOOD'S ADD							
3436 MCBRIDE, FOURTH	3-211200000 - LASKY MARK D ET AL 409 MCBRIDE ST JACKSON MI 49203	0.00 0.00	0.00		0.00	12,195.48 0.00	12,195.48
LOT 23 BLK 12 HARWOOD'S ADD							
3436 MCBRIDE, FOURTH	3-211400000 - RIGGINS JEMIASE M & ANGELA L 405 MCBRIDE ST JACKSON MI 49203	0.00 0.00	0.00		0.00	8,006.51 0.00	8,006.51
W 43.33 FT OF LOT 25 & 26 BLK 12 HARWOOD'S ADD							
3436 MCBRIDE, FOURTH	3-211500000 - ION SHAWN & EMMA 1032 FIRST ST JACKSON MI 49203	0.00 0.00	0.00		0.00	10,894.40 0.00	10,894.40
E 88 FT OF LOT 25 BLK 12 HARWOOD'S ADD							
Total Parcels: 29		0.00 0.00	0.00		0.00	285,670.35 0.00	285,670.35

RESOLUTION
STREET RECONSTRUCTION AND WATER AND SEWER MAIN REPLACEMENT ON WILLIAMS STREET

BY THE BOARD OF REVIEW:

WHEREAS, the Assessor, in accordance with the direction of the City Council, did prepare special assessments concerning street reconstruction and water sewer main replacement on Williams Street, from Biddle to Wilkins Street which assessments were by him placed on Assessment Roll No. 3439 in the amount of \$44,600.00 and reported to the City Council as its meeting held on the 11th day of July, 2023; and

WHEREAS, notice has been duly given that the City Council and Assessor would sit as a Board of Review in the Council Chambers in the City of Jackson on Tuesday, July 11, 2023, at 6:30 p.m. to hear any and all objections and suggestions by interested parties to said special assessment as contained in said roll; and

WHEREAS, the matter of said review having come on to be heard and the City Council and Assessor sitting as a Board of Review having heard all suggestions and objections made thereto and having fully considered the same;

NOW, THEREFORE, BE IT RESOLVED, that each and all of the special assessments as contained in said roll are hereby confirmed and made valid liens against the property and valid claims against the owners thereof, and the City Clerk is hereby directed to make certificates of this determination and attach the same to said roll and to turn said roll over to the City Treasurer for collection; and

BE IT FURTHER RESOLVED that each and all of the special assessments contained in Roll No. 3439 shall be divided into 10 equal installments, the first of which shall be payable by the first summer tax bill following the date of the confirmation without interest charge; and the remaining installments, plus a 2.75% annual interest charge on each installment, shall be due annually each subsequent year at the same times with the same installments as the summer tax bill until each of the special assessments has been paid in full; provided, however, that in the event the City issues bonds in anticipation of special assessments, the unpaid balance of said special assessments shall, in accordance with Section 22-9 of the Jackson City Code of Ordinances, bear a rate of interest which may not be in excess of six percent (6%) per annum, or one percent (1%) above the average interest cost of said special assessment bonds.

BE IT FURTHER RESOLVED that the unpaid balance of any special assessment, including pro rata interest charges, may be paid in full at any time and that each and any special assessment may be paid without interest if payment in full by the first summer tax bill following the date of confirmation.

* * * * *

State of Michigan)
County of Jackson) ss
City of Jackson)

I, Andrea Muray, City Clerk in and for the City of Jackson, County and State aforesaid, do hereby certify that the foregoing is a true and complete copy of a resolution adopted by the Jackson City Council sitting as a Board of Review on the 11th day of July, 2023.

IN WITNESS WHEREOF, I have affixed my signature and the Seal of the City of Jackson, Michigan, on this 12th day of July 2023.

Andrea Muray, City Clerk

Special Assessment Roll for CITY OF JACKSON
Roll for Year 2023
Population: Special Assessment District (3439)
Special Population Both Active and Inactive Parcels

Sp. District Heading	Parcel # Owner	Principal Admin Fee	Interest Penalty	Addtl Penlty Cert Fee	Total Installment	Prin Bal Payoff Int	Total Payoff
3439	4-073700000	0.00	0.00		0.00	200.00	200.00
WILLIAMS, BIDDLE	RODRIGUEZ VICTORIA L 136 W BIDDLE ST JACKSON MI 49203	0.00				0.00	
E 90 FT OF LOT 131 ASSESSOR'S SOUTH PLAT							
3439	4-075100000	0.00	0.00		0.00	150.00	150.00
WILLIAMS, BIDDLE	BEAVERS WANDA A 122 W BIDDLE ST JACKSON MI 49203	0.00				0.00	
LOT 148 & W 2 FT OF LOT 149 ASSESSOR'S SOUTH PLAT							
3439	4-076100000	0.00	0.00		0.00	9,800.00	9,800.00
WILLIAMS, BIDDLE	PARTNERSHIP PARK I LTD DIV HOUSING 4275 FIVE OAKS DR LANSING MI 48911	0.00				0.00	
LOT 158 EX E 66 FT ASSESSOR'S SOUTH PLAT							
3439	4-076200000	0.00	0.00		0.00	7,700.00	7,700.00
WILLIAMS, BIDDLE	BROW WILLIAM C & PENNY D LE 678 DOLLAR LAKE DR JACKSON MI 49201	0.00				0.00	
LOT 159 ASSESSOR'S SOUTH PLAT							
3439	4-076300000	0.00	0.00		0.00	26,750.00	26,750.00
WILLIAMS, BIDDLE	WILLIAMS & WILKINS LLC 636 CHESTER ST JACKSON MI 49203	0.00				0.00	
LOT 160 ASSESSOR'S SOUTH PLAT							
Total Parcels: 5		0.00	0.00		0.00	44,600.00	44,600.00
		0.00				0.00	



City of Jackson, Michigan Financial Statements

As of and For the Eleven Months Ended May 31, 2023

Preliminary/Unaudited

INDEX:	Page
General Fund Expenditure Summary	1-2
All Other Funds - Expenditure Summary	3-4
All Funds - Revenue Summary	5-6
Notes to Revenue & Expenditure Summaries	7

City of Jackson, Michigan
General Fund Expenditure Summary
As of and For the Eleven Months Ended May 31, 2023
(Prepared on the Adopted Budget-Basis)
Preliminary/Unaudited

Function Department	2022/23 Budget		Actual Month To Date	Actual Year To Date	Percent Spent	Variance - Favorable (Unfavorable)
	Original	Amended				
<u>General Government :</u>						
101-101 City Council	114,696	124,345	14,776	111,863	89.96%	12,482
101-103 Charter Review Committee	2,500	2,500	0	0	0.00%	2,500
101-172 City Manager	474,901	485,430	48,820	432,456	89.09%	52,974
101-191 Finance	587,942	574,115	39,490	475,452	82.81%	98,663
101-215 City Clerk	331,401	329,518	22,985	273,953	83.14%	55,565
101-228 Management Info. Services	448,021	431,075	26,573	337,003	78.18%	94,072
101-233 Purchasing	130,276	130,276	8,490	107,541	82.55%	22,735
101-253 City Treasurer	413,354	394,583	30,787	335,143	84.94%	59,440
101-254 City Income Tax	235,063	222,765	17,996	162,540	72.96%	60,225
101-257 City Assessor	544,375	480,008	35,989	385,247	80.26%	94,761
101-262 City Clerk-Elections	114,367	131,430	14,502	110,313	83.93%	21,117
101-265 City Hall & Grounds	431,258	608,614	(21,267)	374,882	61.60%	233,732
101-266 City Attorney	731,548	744,026	53,992	623,672	83.82%	120,354
101-270 Personnel	645,907	636,494	48,116	432,255	67.91%	204,239
101-278 Unallocated	879,799	812,859	49,075	623,420	76.69%	189,439
	6,085,408	6,108,038	390,324	4,785,740	78.35%	1,322,298
<u>Judicial:</u>						
101-299 Admin. Hearings Bureau	199,201	303,436	7,083	187,025	61.64%	116,411
	199,201	303,436	7,083	187,025	61.64%	116,411
<u>Public Safety:</u>						
101-301 Police	11,454,098	11,000,196	843,799	9,804,832	89.13%	1,195,364
101-311 OSHP Grant	0	18,182	0	6,064	33.35%	12,118
101-320 Consortium Training	15,750	13,652	0	10,754	78.77%	2,898
101-321 In Service Training	3,185	5,300	3,565	9,906	186.91%	(4,606)
101-340 Fire Suppression	5,709,356	6,322,898	406,120	5,842,757	92.41%	480,141
101-350 Public Safety - Unallocated	2,107,885	1,929,335	135,162	1,782,202	92.37%	147,133
	19,290,274	19,289,563	1,388,646	17,456,515	90.50%	1,833,048
<u>Public Works :</u>						
101-442 Forestry	658,542	939,187	48,507	711,355	75.74%	227,832
101-444 Sidewalk Construction	55,707	73,704	1,123	35,199	47.76%	38,505
101-445 Drains at Large	78,779	106,865	0	68,805	64.38%	38,060
101-450 Street Lighting	601,899	602,066	44,148	450,287	74.79%	151,779
101-455 Weed Control	103,918	92,951	1,531	54,707	58.86%	38,244
101-465 Grounds Maintenance	467,230	460,192	4,141	328,399	71.36%	131,793
101-567 Cemeteries	358,075	363,288	56,514	287,221	79.06%	76,067
101-571 Tax Property Maintenance	226,695	242,266	197	133,591	55.14%	108,675
101-572 Civic Affairs	107,802	117,914	19,657	72,503	61.49%	45,411
	2,658,647	2,998,433	175,818	2,142,067	71.44%	856,366
<u>Community & Economic Development:</u>						
101-701 Planning	234,974	243,567	16,329	198,869	81.65%	44,698
101-728 Economic Development	132,400	132,400	3,585	122,898	92.82%	9,502
	367,374	375,967	19,914	321,767	85.58%	54,200

Note 2

(Continued -)

City of Jackson, Michigan
General Fund Expenditure Summary
As of and For the Eleven Months Ended May 31, 2023
(Prepared on the Adopted Budget-Basis)

- Continued -

Function Department	2022/23 Budget		Actual Month To Date	Actual Year To Date	Percent Spent	Variance - Favorable (Unfavorable)	
	Original	Amended					
<u>Recreation & Culture :</u>							
101-752	Parks, Rec. & Grnds. Admin.	305,867	306,867	49,016	314,976	102.64%	(8,109) Note 2
101-758	Lt. Nixon Memorial Pool	100,476	130,229	6,747	92,292	70.87%	37,937
101-771	Parks & Facilities Maintenance	836,134	850,475	(95,118)	800,020	94.07%	50,455
101-803	Historical District	12,790	13,500	979	10,258	75.99%	3,242
101-806	Diversity, Equity & Inclusion	306,235	296,911	18,620	256,887	86.52%	40,024
		1,561,502	1,597,982	(19,756)	1,474,433	92.27%	123,549
<u>Contributions to Other Funds:</u>							
101-965	Contributions to Other Funds	293,429	1,778,829	85,955	108,429	6.10%	1,670,400
	Total General Fund Expenditures	30,455,835	32,452,248	2,047,984	26,475,976	81.58%	5,976,272
 <u>Funds Consolidated with the General Fund</u> <u>for Financial Reporting Purposes:</u>							
102	Budget Stabilization	25,000	20,000	0	0	0.00%	20,000

City of Jackson
All Other Funds - Expenditure Summary
As of and For the Eleven Months Ended May 31, 2023
(Prepared on the Adopted Budget-Basis)
- Continued -

Fund Type/Fund Name	2022/23 Budget		Actual Month To Date	Actual Year To Date	Percent Spent	Variance - Favorable (Unfavorable)
	Original	Amended				
<u>Permanent Funds :</u>						
151 Cemetery Perpetual Maint.	5,000	5,000	0	0	0.00%	5,000
155 Ella W. Sharp Endowment	23,850	34,264	0	0	0.00%	34,264
160 Lloyd E. Mount Endowment	7,000	5,598	0	0	0.00%	5,598
<u>Special Revenue Funds :</u>						
202 Major Street	24,731,248	34,872,507	1,020,361	7,471,529	21.43%	27,400,978
203 Local Street	3,898,044	1,903,609	203,847	1,159,452	60.91%	744,157
208 Ella W. Sharp Park Operating	986,741	1,048,653	144,196	851,154	81.17%	197,499
218 Affordable Housing	3,250,000	845,700	49,732	619,558	73.26%	226,142
245 Public Improvement	1,027,676	1,504,210	259,944	434,764	28.90%	1,069,446
246 Cortland St. Redev. Project	2,520,493	2,523,391	9,146	32,495	1.29%	2,490,896
249 Building Department	597,332	609,993	(11,604)	481,954	79.01%	128,039
251 Housing Code Enforcement	1,156,790	1,294,179	60,233	1,011,370	78.15%	282,809
252 Building Demolitions	406,815	344,850	10,963	101,139	29.33%	243,711
265 Drug Law Enforcement	16,702	9,830	2,167	11,948	121.55%	(2,118) Note 2
272 SAFER Grant	524,760	562,182	139,744	413,077	73.48%	149,105
273 Project Safe Neighborhoods	120,969	50,129	9,229	76,801	153.21%	(26,672) Note 2
275 Byrne/JAG Programs	0	52,715	25,000	68,614	130.16%	(15,899) Note 2
279 American Rescue Plan Act	200,000	65,000	0	66,283	101.97%	(1,283) Note 2
296 Recreation Activity	206,248	272,324	26,651	244,141	89.65%	28,183
297 Recreation Millage Program	657,274	643,386	(8,021)	584,224	90.80%	59,162
<u>Debt Service Funds :</u>						
308 2020 Capital Improvement D/S	223,702	223,702	206,851	223,702	100.00%	0
352 2017 Mich. Trans. Fund D/S	761,890	761,890	688,445	761,890	100.00%	0
367 2021 City Hall Refunding D/S	729,581	729,581	0	729,581	100.00%	0
385 2016 Capital Improvement D/S	144,087	144,087	0	144,087	100.00%	0
386 2018 Capital Improvement D/S	1,410,000	1,410,000	1,117,750	1,410,000	100.00%	0
389 2017 BRA TIF Refunding D/S	420,556	420,556	312,778	420,556	100.00%	0
391 2021 BRA TIF Refunding D/S	772,512	772,512	740,256	772,512	100.00%	0
394 2001 DDA TIF D/S	2,735,750	2,735,750	2,735,750	2,735,750	100.00%	0
395 2019 DDA TIF Refunding D/S	209,573	209,573	124,787	209,573	100.00%	0
<u>Capital Projects Funds :</u>						
401 Capital Projects	1,955,898	607,658	108,220	443,035	72.91%	164,623
402 Water Equip. and Replacemt.	9,825,900	5,812,315	588,862	2,669,393	45.93%	3,142,922
403 Lead Service Line Replacement	1,661,966	1,316,891	76,412	208,051	15.80%	1,108,840
404 Sanitary Sewer Maint.	399,931	474,399	15,500	273,487	57.65%	200,912
405 Sanitary Sewer Replacement	1,902,121	848,400	131,976	414,687	48.88%	433,713
406 Wastewater Equip. Replacemt.	17,594,940	5,030,754	343,728	1,311,008	26.06%	3,719,746
407 2022 Sewer Sys. Project Const.	0	5,756,226	292,843	1,005,249	17.46%	4,750,977
409 2022 Water Sys. Project Const.	0	311,845	0	0	0.00%	311,845
488 MLK Corridor Improvemt. Authority	10,000	100,000	25,318	91,859	91.86%	8,141
489 Brownfield Redevelopmt. Auth.	1,450,079	1,758,217	1,053,949	1,397,360	79.48%	360,857
494 DDA Project	2,947,323	2,945,323	2,860,537	2,945,323	100.00%	0

(Continued -)

City of Jackson
All Other Funds - Expenditure Summary
As of and For the Eleven Months Ended May 31, 2023
(Prepared on the Adopted Budget-Basis)

- Continued -

Fund Type/Fund Name	2022/23 Budget		Actual Month To Date	Actual Year To Date	Percent Spent	Variance - Favorable (Unfavorable)	
	Original	Amended					
<u>Enterprise Funds :</u>							
514	Auto Parking System	247,011	311,469	81,484	146,177	46.93%	165,292
518	Parking Assessment	303,267	330,718	14,259	215,578	65.18%	115,140
519	Cooper/Francis Parking Deck	283,775	283,344	5,963	47,053	16.61%	236,291
590	Sewer	18,162,790	15,261,012	1,254,753	6,826,082	44.73%	8,434,930
591	Water	19,257,736	14,182,982	670,622	10,553,369	74.41%	3,629,613
<u>Internal Service Funds :</u>							
641	Public Works Administration	477,472	429,245	688	299,328	69.73%	129,917
642	Engineering Administration	328,453	328,184	50,092	265,359	80.86%	62,825
643	Local Site Remed. Revolving	20,000	40,000	0	22,500	56.25%	17,500
661	Motor Pool and Garage	2,881,943	3,109,537	222,440	1,967,129	63.26%	1,142,408
676	Workers' Compensation	183,900	425,339	20,479	320,375	75.32%	104,964
677	Self-Insured Health Care	5,680,600	5,414,911	430,048	4,973,571	91.85%	441,340
<u>Trust & Agency Funds :</u>							
703	County & School Tax Collection	65,000	27,075,000	0	0	0.00%	27,075,000
731	Employees' Retirement System	4,220,000	4,210,000	358,379	3,600,584	85.52%	609,416
732	Policemen's/Firemen's Pension	548,000	548,000	36,842	480,996	87.77%	67,004
734	Police./Fire. Pension-345	7,640,000	6,240,000	871,593	5,207,716	83.46%	1,032,284
736	Public Employee Health Care	10,000	10,000	0	6,222	62.22%	3,778
<u>Special Assessment Funds :</u>							
852	2020 Special Assessment D/S	161,335	161,335	0	161,288	99.97%	47
895	Special Assessment	2,055,241	841,612	169,318	610,608	72.55%	231,004

City of Jackson
All Funds - Revenue Summary
As of and For the Eleven Months Ended May 31, 2023
(Prepared on the Adopted Budget-Basis)

Fund/Fund Name	2022/23 Budget		Actual Month To Date	Actual Year To Date	Percent Collected	
	Original	Amended				
<u>General Fund :</u>						
Property Taxes	10,423,356	10,439,532	705,675	10,733,158	102.81%	
Income Taxes	10,500,000	10,500,000	804,365	11,322,453	107.83%	
State Revenue Sharing	5,028,914	5,417,959	0	3,657,606	67.51%	
Licenses & Permits	367,025	373,562	79,434	300,275	80.38%	
Federal Grants	1,346,427	947,291	1,808	973,873	102.81%	
State Grants	3,185	4,021	0	8,607	214.05%	
Charges For Goods & Services	1,294,072	1,248,210	666,051	1,010,841	80.98%	
Fines & Forfeits	377,094	466,500	56,295	429,084	91.98%	
Investment Income	115,000	235,000	47,884	332,285	141.40%	
Contributions From Other Funds	120,000	125,000	0	16,752	13.40%	
Contributions From Local Units	12,500	12,500	0	16,945	135.56%	
Miscellaneous	225,323	301,701	44,754	500,508	165.90%	
Total General Fund Revenues	29,812,896	30,071,276	2,406,266	29,302,387	97.44%	
<u>Funds Consolidated with the General Fund for Financial Reporting Purposes:</u>						
102	Budget Stabilization	25,000	20,000	2,568	17,460	87.30%
<u>Permanent Funds :</u>						
151	Cemetery Perpetual Maint.	37,000	37,000	5,164	33,036	89.29%
155	Ella W. Sharp Endowment	23,850	34,264	0	0	0.00%
160	Lloyd E. Mount Endowment	7,000	5,598	0	0	0.00%
<u>Special Revenue Funds :</u>						
202	Major Street	24,253,509	33,056,161	291,064	6,069,417	18.36%
203	Local Street	2,889,376	1,225,334	93,520	1,181,309	96.41%
208	Ella W. Sharp Park Operating	921,600	981,362	96,208	558,712	56.93%
213	Opioid Settlement Fund	0	118,175	0	118,176	N/A
218	Affordable Housing	3,250,000	845,700	0	388,813	45.98%
245	Public Improvement	1,269,500	1,289,000	134,188	1,332,152	103.35%
246	Cortland St. Redev. Project	2,500,000	2,501,000	1,985	5,570	0.22%
249	Building Department	497,500	495,180	73,967	506,131	102.21%
251	Housing Code Enforcement	1,157,500	1,550,000	72,312	1,606,399	103.64%
252	Building Demolitions	407,465	160,636	760	109,352	68.07%
265	Drug Law Enforcement	15,610	20,700	2,222	4,540	21.93%
272	SAFER Grant	524,760	562,182	0	218,379	38.84%
273	Project Safe Neighborhood	120,969	50,129	9,229	76,801	153.21%
275	Byrne/JAG Programs	0	52,715	25,145	68,614	130.16%
279	American Rescue Plan Act	200,000	65,000	0	45,028	69.27%
296	Recreation Activity	208,000	275,250	27,380	258,515	93.92%
297	Recreation Millage Program	676,000	650,000	430	305,476	47.00%
<u>Debt Service Funds :</u>						
308	2020 Capital Improvement D/S	223,702	216,614	206,851	223,702	103.27%
352	2017 Mich. Trans. Fund D/S	761,890	761,890	688,445	761,890	100.00%
367	2021 City Hall Refunding D/S	668,000	676,500	93,570	763,990	112.93%
385	2016 Capital Improvement D/S	144,087	144,087	0	144,087	100.00%

(Continued-)

City of Jackson
All Funds - Revenue Summary
As of and For the Eleven Months Ended May 31, 2023
(Prepared on the Adopted Budget-Basis)

- Continued -

Fund/Fund Name	2022/23 Budget		Actual Month To Date	Actual Year To Date	Percent Collected	
	Original	Amended				
<u>Debt Service Funds (Continued) :</u>						
386	2018 Capital Improvement D/S	1,410,000	1,410,000	1,117,750	1,410,000	100.00%
389	2017 BRA TIF Refunding D/S	420,556	420,556	312,778	420,556	100.00%
391	2021 BRA TIF Refunding D/S	772,512	772,512	740,256	772,512	100.00%
394	2001 DDA TIF D/S	2,735,750	2,735,750	2,735,750	2,735,750	100.00%
395	2019 DDA TIF Refunding D/S	209,573	209,573	124,787	209,573	100.00%
<u>Capital Projects Funds :</u>						
401	Capital Projects	1,956,398	590,825	0	569	0.10%
402	Water Equip. and Replacem.	7,808,191	4,688,862	(546,854)	3,939,923	84.03%
403	Lead Service Line Replacement	2,637,759	2,107,090	92,678	1,029,417	48.85%
404	Sanitary Sewer Maintenance	399,931	474,399	15,500	273,487	57.65%
405	Sanitary Sewer Replacement	672,950	1,107,862	263,801	880,324	79.46%
406	Wastewater Equip. Replacem.	16,095,054	4,997,578	144,813	1,705,244	34.12%
407	2022 Sewer Sys. Project Const.	0	6,237,198	210,689	750,084	12.03%
409	2022 Water Sys. Project Const.	0	311,845	0	0	0.00%
488	MLK Corridor Improvemt. Authority	10,000	100,000	0	2,075	2.08%
489	Brownfield Redevelopmt. Auth.	1,559,350	1,895,252	1,878,595	1,905,890	100.56%
494	DDA Project	3,405,000	3,482,999	1,774,966	3,554,877	102.06%
<u>Enterprise Funds :</u>						
514	Auto Parking System	93,743	96,423	962	5,811	6.03%
518	Parking Assessment	221,288	280,776	27,842	298,509	106.32%
519	Cooper/Francis Parking Deck	11,050	15,630	3,748	22,500	143.95%
590	Sewer	6,949,219	13,378,970	820,011	6,434,962	48.10%
591	Water	15,234,895	14,650,309	1,069,411	11,415,592	77.92%
<u>Internal Service Funds :</u>						
641	Public Works Administration	399,794	354,172	25,479	315,601	89.11%
642	Engineering Administration	265,891	259,042	21,655	248,712	96.01%
643	Local Site Remed. Revolving	67,950	61,659	728	12,785	20.74%
661	Motor Pool and Garage	2,823,832	2,905,486	111,047	2,063,682	71.03%
676	Workers' Compensation	185,000	640,000	13,167	138,190	21.59%
677	Self-Insured Health Care	5,940,600	5,677,000	385,049	4,440,906	78.23%
<u>Trust & Agency Funds :</u>						
703	County & School Tax Collection	65,000	27,075,000	11,686	87,107	0.32%
731	Employees' Retirement System	6,040,000	5,090,000	(449,351)	4,315,860	84.79%
732	Policemen's/Firemen's Pension	561,185	549,185	(43,862)	457,259	83.26%
734	Police./Fire. Pension-345	9,629,911	10,504,911	(283,557)	8,775,135	83.53%
736	Public Employees Health Care	230,000	137,438	1,399	299,428	217.86%
<u>Special Assessment Funds :</u>						
852	2020 Special Assessment D/S	161,335	161,335	0	161,288	99.97%
895	Special Assessment	2,055,241	1,010,959	9,501	306,720	30.34%

City of Jackson
Notes to Revenue & Expenditure Summaries
As of and For the Eleven Months Ended May 31, 2023
(Prepared on the Adopted Budget-Basis)

Note 1: Revenues do not include budgeted appropriations from fund balance. These appropriations, together with budgeted revenues, are sufficient to fund budgeted expenditures, in accordance with State law.

Note 2: A Budget Amendment is pending to correct this variance.



CITY COUNCIL MEETING MINUTES

June 13, 2023

CALL TO ORDER:

The Jackson City Council met in regular session in Council Chambers and was called to order at 6:30 p.m. by Mayor Daniel Mahoney.

PLEDGE OF ALLEGIANCE AND INVOCATION:

Council joined in the Pledge of Allegiance. Invocation was given by Second Ward Councilmember Freddie Dancy.

ROLL CALL:

Present: Mayor Daniel Mahoney, Vice Mayor/First Ward Councilmember Arlene Robinson, Second Ward Councilmember Freddie Dancy, Third Ward Councilmember Angelita Gunn, Fourth Ward Councilmember Laura Dwyer Schlecte, Fifth Ward Councilmember Karen Bunnell, and Sixth Ward Councilmember Will Forgrave.

Absent: none.

Also present: City Manager Jonathan Greene, City Attorney Matthew Hagerty, City Clerk Andrea Muray, City Assessor Jason Yoakam, Director of Parks and Recreation Kelli Hoover, Chief Equity Officer John Willis, Director of Police and Fire Services Elmer Hitt, Director of Community Development Shane LaPorte, Director of Public Works Mike Osborne, Director of Finance Heather Ehnis, and City Engineer Jon Dowling.

ADOPTION OF AGENDA:

Motion was made by Councilmember Schlecte, seconded by Councilmember Gunn to adopt the agenda. Vote - Yeas: Mayor Mahoney, Vice Mayor Robinson, Councilmembers Dancy, Gunn, Schlecte, Bunnell, and Forgrave (7). Nays: none. Motion carried.

PRESENTATIONS/PROCLAMATIONS: none.

PUBLIC HEARINGS:

Motion was made by Councilmember Bunnell, seconded by Vice Mayor Robinson to recess as a City Council and convene as a Board of Review. Vote - Yeas: Mayor Mahoney, Vice Mayor Robinson, Councilmembers Dancy, Gunn, Schlecte, Bunnell, and Forgrave (7). Nays: none. Motion carried.

6.1 Special Assessment Roll No. 3445 Confirmation

Motion was made by Councilmember Gunn, seconded by Vice Mayor Robinson to conduct a public hearing regarding the confirmation of Special Assessment Roll No. 3445. Vote - Yeas: Mayor Mahoney, Vice Mayor Robinson, Councilmembers Dancy, Gunn, Schlecte, Bunnell, and Forgrave (7). Nays: none. Motion carried.

Letters of protest were read into the record from John Lennox of 612 Wildwood and Gae Winn of 511 Wildwood.

Motion was made by Councilmember Forgrave, seconded by Councilmember Schlecte to close the public hearing. Vote - Yeas: Mayor Mahoney, Vice Mayor Robinson, Councilmembers Dancy, Gunn, Schlecte, Bunnell, and Forgrave (7). Nays: none. Motion carried.

Motion was made by Councilmember Forgrave, seconded by Councilmember Schlecte to adopt the resolution confirming Special Assessment Roll No. 3445. Vote - Yeas: Mayor Mahoney, Vice Mayor Robinson, Councilmembers Dancy, Gunn, Schlecte, Bunnell, and Forgrave (7). Nays: none. Motion carried.

6.2 Special Assessment Roll No. 3446 Confirmation

Motion was made by Councilmember Bunnell, seconded by Councilmember Schlecte to conduct a public hearing regarding the confirmation of Special Assessment Roll No. 3446. Vote - Yeas: Mayor Mahoney, Vice Mayor Robinson, Councilmembers Dancy, Gunn, Schlecte, Bunnell, and Forgrave (7). Nays: none. Motion carried.

A letter of protest was read into the record from Ruth Pearson of 1202 Wildwood.

Motion was made by Councilmember Schlecte, seconded by Councilmember Gunn to close the public hearing. Vote - Yeas: Mayor Mahoney, Vice Mayor Robinson, Councilmembers Dancy, Gunn, Schlecte, Bunnell, and Forgrave (7). Nays: none. Motion carried.

Motion was made by Councilmember Forgrave, seconded by Councilmember Dancy to adopt the resolution confirming Special Assessment Roll No. 3446. Vote - Yeas: Mayor Mahoney, Vice Mayor Robinson, Councilmembers Gunn, Schlecte, Bunnell, and Forgrave (6). Nays: Councilmember Dancy (1). Motion carried.

CITIZEN COMMENTS:

Citizen comments were heard and the meeting continued.

PETITIONS & COMMUNICATION FROM CITY STAFF AND OTHER GOVERNMENTAL ENTITIES:

8.1 City of Jackson, Michigan Financial Statements as of and for the 10 Months Ended April 30, 2023.

8.2 April 19, 2023 Environmental Commission Meeting Minutes

8.3 March Board of Review Minutes

Motion was made by Councilmember Schlecte, seconded by Councilmember Forgrave to accept and place on file 8.1, 8.2 the April 19, 2023 Environmental Commission Meeting Minutes, and 8.3 the March Board of Review Minutes. Vote - Yeas: Mayor Mahoney, Vice Mayor Robinson, Councilmembers Dancy, Gunn, Schlecte, Bunnell, and Forgrave (7). Nays: none. Motion carried.

CONSENT CALENDAR:

9.1 Minutes of the Regular Meeting on May 23, 2023

Approve the minutes of the regular City Council meeting held on May 23, 2023

9.2 Approve the Mayor's recommendation to appoint Maurice Imhoff to the Human Relations Commission

Approve the Mayor's recommendation to appoint Maurice Imhoff to the Human Relations Commission for a two-year term, beginning immediately and ending on December 31, 2025, in concurrence with the HRC recommendation.

9.3 Special Event Application: Barbeque Battle of Jackson

Approve a request from the Barbeque Battle of Jackson on July 30, 2023, at the Grand River Pavilion and Parking lot in downtown Jackson.

- 9.4 Special Event Application for the Everyheart Night of Worship**
Approve a request from the Everyheart Movement to host the Everyheart Night of Worship on June 16, 2023, in Horace Blackman Park and the True Community Credit Union City Square.
- 9.5 Special Event Application for the YPOP Explorers' Art in the Garden**
Approve a request from the YPOP Explorers to host their Art in the Garden event on June 24 on the streets of Jackson.
- 9.6 Special Event Application for the Jackson Festival of the Arts**
Approve a request from the Monster Box Theatre to host their Jackson Festival of the Arts on September 7-11, 2023, at the True Community Credit Union City Square and various other locations in Jackson.
- 9.7 Special Event Application for the Nation Night Out**
Approve a request from the Ward 2- B2 Watchers Neighborhood Watch Group to host their National Night Out on August 1, 2023, at Loomis Park in the City of Jackson.
- 9.8 Special Event Application: Michigan Theater Capital Campaign**
Approve a request from the Michigan Theatre to host their "Michigan Theatre Capital Campaign" on July 29, 2023, at the Michigan Theater and parking lot number 14.
- 9.9 Special Event Application: Big Miles for Little Smiles**
Approve a request from the Big Brothers Big Sisters to host Big Miles for Little Smiles on September 24, 2023, at Ella Sharp Park.
- 9.10 Special Event Application: Bike Night**
Approve a request from the Bella Notte Ristorante to host their Bike Night every Tuesday, May through October, during nice weather on a section of Michigan Ave in downtown Jackson.
- 9.11 Special Event Application: Jackson Pride Festival**
Approve a request from the Jackson Pride Center to host the Pride Festival on August 19, 2023, in Horace Blackman Park, True Community Credit Union City Square, and the streets of downtown Jackson.
- 9.12 Special Event Application: Heart of a Lion 5K**
Approve the Area 19 Special Olympics request to host "Heart of a Lion 5K" on August 20, 2023, at Ella Sharp Park.
- 9.13 Corrective Resolution -Resolution No. 2023-17**
Approve a resolution correcting a typographical error in Resolution No. 2023-17

9.14 Corrective Resolution for Drinking Water State Revolving Fund Tentative Contract Award to Northwoods Plumbing, LLC of Concord, MI

Approval of the corrective resolution to amend the contract amount to \$703,125 for the resolution of the tentative contract award to Northwoods Plumbing, LLC of Concord, MI for the Drinking Water State Revolving Fund Plumbing for Lead Service Line Replacement.

Motion was made by Councilmember Forgrave, seconded by Councilmember Schlecte to approve the consent calendar. Vote - Yeas: Mayor Mahoney, Vice Mayor Robinson, Councilmembers Dancy, Gunn, Schlecte, Bunnell, and Forgrave (7). Nays: none. Motion carried.

OTHER BUSINESS:

10.1 Ordinance No. 2023-05 Workforce Housing PILOT Ordinance

Recommendation: *Approve the second reading and final adoption of Ordinance No. 2023-05, amending Chapter 24, Taxation, in order to provide for the approval of a PILOT for housing being developed or rehabilitated for workforce housing under the authority of the State Housing Development Authority Act of 1966, Public Act 346 of 1966, as amended by MCL 125.1415a.*

Motion was made by Councilmember Schlecte, seconded by Councilmember Dancy to approve the second reading and final adoption of Ordinance No. 2023-05, amending Chapter 24, Taxation, in order to provide for the approval of a PILOT for housing being developed or rehabilitated for workforce housing under the authority of the State Housing Development Authority Act of 1966, Public Act 346 of 1966, as amended by MCL 125.1415a. Vote - Yeas: Mayor Mahoney, Vice Mayor Robinson, Councilmembers Dancy, Gunn, Schlecte, Bunnell, and Forgrave (7). Nays: none. Motion carried.

10.2 Update - City Homeless Efforts, Winter Sheltering of the Unhoused

Recommendation: *Establish an ad-hoc committee to work with stakeholders in the homeless service sector.*

Motion was made by Mayor Mahoney, seconded by Councilmember Dancy to establish an ad-hoc committee to work with local stakeholders and develop plans to address homelessness in the City of Jackson. Vote - Yeas: Mayor Mahoney, Vice Mayor Robinson, Councilmembers Dancy, Gunn, Schlecte, Bunnell, and Forgrave (7). Nays: none. Motion carried.

Motion was made by Councilmember Forgrave, seconded by Councilmember Bunnell to have Mayor Mahoney, Councilmember Gunn, and Councilmember Dancy appointed to the ad-hoc committee (that was just created).

Councilmember Gunn declined to serve on the committee.

A motion to amend was made by Councilmember Forgrave, seconded by Councilmember Gunn to replace Councilmember Gunn with Councilmember Schlecte. Vote was taken on the motion as amended. Vote - Yeas: Mayor Mahoney, Vice Mayor Robinson, Councilmembers Dancy, Gunn, Schlecte, Bunnell, and Forgrave (7). Nays: none. Motion carried.

NEW BUSINESS:

11.1 Downtown Development Authority Budget, Fiscal Year 2023 – 2024

Recommendation: *Approval for the Jackson Downtown Development Authority budget for the fiscal year 2023-2024.*

Motion was made by Councilmember Dancy, seconded by Councilmember Bunnell to approve the Jackson Downtown Development Authority budget for the fiscal year 2023/24. Councilmember Schlecte informed the Council that she would be abstaining from the vote because of a potential conflict of interest. Vote - Yeas: Mayor Mahoney, Vice Mayor Robinson, Councilmembers Dancy, Gunn, Bunnell, and Forgrave (6). Nays: none. Abstention: Councilmember Schlecte. Motion carried.

11.2 Resolution to Place Delinquent Invoices on 2023 Summer Tax Bills

Recommendation: *Place 90-days overdue invoices on summer tax bills per Section 22-12 of Chapter 22 of the Code of Ordinances.*

Motion was made by Councilmember Schlecte, seconded by Councilmember Gunn to place 90 days overdue invoices on the summer tax bills per Section 22-12 of Chapter 22 of the Code of Ordinances. Vote - Yeas: Mayor Mahoney, Vice Mayor Robinson, Councilmembers Dancy, Gunn, Schlecte, Bunnell, and Forgrave (7). Nays: none. Motion carried.

11.3 Renewal of Liability and Property Insurance with the MML Liability & Property Pool

Recommendation: *Approve the renewal of the City of Jackson's Liability and Property Insurance through the MML Liability & Property Pool in the Amount of \$620,298.00 and authorize the City Attorney and Finance Director to take action necessary to effectuate the policy.*

Motion was made by Councilmember Bunnell, seconded by Vice Mayor Robinson to approve the renewal of the City of Jackson's Liability and Property Insurance through the MML Liability & Property Pool in the Amount of \$620,298.00 and authorize the City Attorney and Finance Director to take action

necessary to effectuate the policy. Vote - Yeas: Mayor Mahoney, Vice Mayor Robinson, Councilmembers Dancy, Gunn, Schlecte, Bunnell, and Forgrave (7). Nays: none. Motion carried.

11.4 Approve a Resolution to Amend the General Fund, Drug Law Enforcement Fund, Project Safe Neighborhood Fund, Byrne/JAG Programs Fund, American Rescue Plan Act Fund, Recreation Activity Fund, and Recreation Millage Fund Budgets for the 2022/23 Fiscal Year.

Recommendation: *Approve a budget resolution amending the General Fund, Drug Law Enforcement Fund, Project Safe Neighborhood Fund, Byrne/JAG Programs Fund, American Rescue Plan Act Fund, Recreation Activity Fund, and Recreation Millage Fund budgets for the fiscal year 2022/23.*

Motion was made by Councilmember Schlecte, seconded by Councilmember Forgrave to approve a resolution to amend the General Fund, Drug Law Enforcement Fund, Project Safe Neighborhood Fund, Byrne/JAG Programs Fund, American Rescue Plan Act Fund, Recreation Activity Fund, and Recreation Millage Fund Budgets for the 2022/23 Fiscal Year. Vote - Yeas: Mayor Mahoney, Vice Mayor Robinson, Councilmembers Dancy, Gunn, Schlecte, Bunnell, and Forgrave (7). Nays: none. Motion carried.

11.5 Approve Program Guidelines and Requests for Proposals for the 100 Homes Program.

Recommendation: *Approve the Program Guidelines, Nonprofit Request for Proposals, and Developer Request for Proposals, for the 100 Homes Program, and authorize the City Manager and City Attorney to make minor modifications as needed.*

Motion was made by Councilmember Dancy, seconded by Vice Mayor Robinson to approve the program guidelines for requests for proposals for the 100 Homes Program. Vote - Yeas: Mayor Mahoney, Vice Mayor Robinson, Councilmembers Dancy, Gunn, Schlecte, Bunnell, and Forgrave (7). Nays: none. Motion carried.

11.6 Approval of updated MAPE wage schedule 2024/2025

Recommendation: *Approve updated MAPE wage schedule 2024/2025*

Motion was made by Councilmember Schlecte, seconded by Councilmember Forgrave to approve the update of MAPE wage schedule for 2024/2025. Vote - Yeas: Mayor Mahoney, Vice Mayor Robinson, Councilmembers Dancy, Gunn, Schlecte, Bunnell, and Forgrave (7). Nays: none. Motion carried.

11.7 Approve the Contract Award for the MLK Equality Trail Reconstruction - West Avenue to Prospect Street project to Dunigan Brothers, Inc. of Jackson, Michigan.

Recommendation: *Approval of an award for the contract for the MLK Equality Trail Reconstruction - West Avenue to Prospect Street project to Dunigan Brothers, Inc. of Jackson, Michigan at a cost of \$695,719.55, and authorization for the Mayor and City Clerk to execute the appropriate document(s) in accordance with the Purchasing Agent.*

Motion was made by Councilmember Bunnell, seconded by Councilmember Schlecte to approve the contract award for the MLK Equality Trail Reconstruction Project, West Avenue to Prospect Street, to Dunigan Brothers in the amount of \$695,719.55. Vote - Yeas: Mayor Mahoney, Vice Mayor Robinson, Councilmembers Dancy, Gunn, Schlecte, Bunnell, and Forgrave (7). Nays: none. Motion carried.

11.8 Award for 2023 Bridge Consulting Services Contract

Recommendation: *Approval of the award for the 2023 Bridge Consulting Services contract to Great Lakes Engineering of Lansing, MI for \$85,240.00, for consulting services related to bridge inspections, and authorization for the Mayor and City Clerk to execute the appropriate document(s) in accordance with the Purchasing Agent.*

Motion was made by Councilmember Schlecte, seconded by Councilmember Dancy to award the 2023 Bridge Consulting Services Contract to Great Lakes Engineering of Lansing, MI in the amount of \$85,240.00. Vote - Yeas: Mayor Mahoney, Vice Mayor Robinson, Councilmembers Dancy, Gunn, Schlecte, Bunnell, and Forgrave (7). Nays: none. Motion carried.

11.9 Resolution for Approval of a Contract with the Michigan Department of Transportation for Street Resurfacing on Wildwood Avenue from West Avenue to Steward Avenue, and on Wisner Street from Wildwood Avenue to Ganson Street.

Recommendation: *Approve a resolution to enter into a contract with the Michigan Department of Transportation (MDOT) for street resurfacing on Wildwood Avenue from West Avenue to Steward Avenue, and street resurfacing on Wisner Street from Wildwood Avenue to Ganson Street, and authorize the Mayor and City Clerk to execute the appropriate documents.*

Motion was made by Councilmember Forgrave, seconded by Councilmember Bunnell to approve a resolution approving a contract with the Michigan Department of Transportation for street reconstruction on Wildwood Avenue, from West Avenue to Steward Avenue, and on Wisner Street from Wildwood Avenue to Ganson Street. Vote - Yeas: Mayor Mahoney, Vice Mayor Robinson, Councilmembers Dancy, Gunn, Schlecte, Bunnell, and Forgrave (7). Nays: none. Motion carried.

11.10 Contract Award for Napoleon Transmission Main Study Engineering

Recommendation: *Approve the award of the Napoleon Transmission Main Study Engineering contract to Fishbeck, of Lansing, Michigan in the amount of \$162,425.08 and authorize the Mayor and City Clerk to execute the appropriate document(s) in accordance with the Purchasing Agent.*

Motion was made by Councilmember Dancy, seconded by Councilmember Schlecte to approve the contract award for Napoleon Transmission Main Study Engineering. Vote - Yeas: Mayor Mahoney, Vice Mayor Robinson, Councilmembers Dancy, Gunn, Schlecte, Bunnell, and Forgrave (7). Nays: none. Motion carried.

11.11 Change Order 4 to the 2021 Morrell and Steward Water Main Replacement Contract

Recommendation: *Approve Change Order 4 to the 2021 Morrell & Steward Water Main Replacement contract with Dunigan Brothers, Inc. in the increased amount of \$247,694.89 for extra work to bore a water main casing pipe through subsurface rock/cobbles within the railroad right-of-way on Steward Avenue and authorize the City Manager and City Engineer to execute the appropriate document.*

Motion was made by Councilmember Forgrave, seconded by Councilmember Gunn to approve Change Order 4 to the 2021 Morrell and Steward Water Main Replacement Contract in the increased amount of \$247,694.89 for extra work to bore a water main casing pipe through subsurface rock/cobbles within the railroad right-of-way on Steward Avenue and authorize the City Manager and City Engineer to execute the appropriate document. Vote - Yeas: Mayor Mahoney, Vice Mayor Robinson, Councilmembers Dancy, Gunn, Schlecte, Bunnell, and Forgrave (7). Nays: none. Motion carried.

11.12 Change Order 4 to the Miscellaneous Construction contract with Bailey Excavating, Inc.

Recommendation: *Approve Change Order 4 to the Miscellaneous Construction contract with Bailey Excavating, Inc. in the increased amount of \$4,505.32 to add temporary traffic control device items to maintain traffic and provide a safe work zone for asphalt patching on E. High Street between Losey Avenue and Executive Drive and authorize the City Manager and City Engineer to execute the appropriate document*

Motion was made by Councilmember Bunnell., seconded by Councilmember Gunn to approve Change Order 4 to the Miscellaneous Construction contract with Bailey Excavating, Inc. in the increased amount of \$4,505.32 to add temporary traffic control device items to maintain traffic and provide a safe work zone for asphalt patching on E. High Street between Losey Avenue and Executive Drive and authorize the City Manager and City Engineer to execute the appropriate document. Vote - Yeas: Mayor Mahoney, Vice Mayor

Robinson, Councilmembers Dancy, Gunn, Schlecte, Bunnell, and Forgrave (7).
Nays: none. Motion carried.

11.13 Resolution for the Grant Agreement with the Michigan Department of Environment, Great Lakes and Energy

Recommendation: *Approval of a resolution to enter into the grant agreement with the Michigan Department of Environment, Great Lakes and Energy (EGLE) for the American Rescue Plan - State Revolving Fund and authorize the Director of Public Works and City Clerk to execute the appropriate documents.*

Motion was made by Councilmember Dancy, seconded by Councilmember Forgrave to approve the resolution for the grant agreement with the Michigan Department of Environment, Great Lakes, and Energy. Vote - Yeas: Mayor Mahoney, Vice Mayor Robinson, Councilmembers Dancy, Gunn, Schlecte, Bunnell, and Forgrave (7). Nays: none. Motion carried.

11.14 Purchase Agreement - 971 N. West Avenue

Recommendation: *Approve the Purchase Agreement from Lormax Stern to purchase city owned property located at 971 N. West Ave and authorize the City Manager and City Attorney to make modifications to effect the sale of the property.*

Motion was made by Councilmember Schlecte, seconded by Vice Mayor Robinson to approve the Purchase Agreement from Lormax Stern to purchase city owned property located at 971 N. West Ave and authorize the City Manager and City Attorney to make modifications to effect the sale of the property. Vote - Yeas: Mayor Mahoney, Vice Mayor Robinson, Councilmembers Dancy, Gunn, Schlecte, Bunnell, and Forgrave (7). Nays: none. Motion carried.

11.15 Approve a one-year contract with MakeMyMove - Community Promotion and Relocation Contract

Recommendation: *Approve a one-year contract with the MakeMyMove organization in the amount of \$24,000, to aid in the recruitment of move-ready talent within the City of Jackson. Authorize the City Manager to make minor modifications and execute the contract.*

Motion was made by Councilmember Schlecte, seconded by Vice Mayor Robinson to approve a one-year contract with the MakeMyMove organization in the amount of \$24,000, to aid in the recruitment of move-ready talent within the City of Jackson. Vote - Yeas: Mayor Mahoney, Vice Mayor Robinson, Councilmembers Dancy, Gunn, Schlecte, Bunnell, and Forgrave (7). Nays: none. Motion carried.

11.16 Dodge Durango Purchase

Recommendation: *Approval for the purchase of one 2023 Dodge Durango for \$45,925 through the John Jones Automotive Group in Salem, Indiana, to be used as a patrol vehicle.*

Motion was made by Councilmember Schlecte, seconded by Councilmember Gunn to approve the purchase of one 2023 Dodge Durango for \$45,925 through the John Jones Automotive Group in Salem, Indiana, to be used as a patrol vehicle. Vote - Yeas: Mayor Mahoney, Vice Mayor Robinson, Councilmembers Dancy, Gunn, Schlecte, and Bunnell (6). Nays: Councilmember Forgrave (1). Motion carried.

CITY COUNCILMEMBER’S COMMENTS:

Mayor Mahoney, Vice Mayor Robinson, and Councilmembers Dancy, Schlecte, and Forgrave offered comments. Councilmembers Gunn and Bunnell declined.

MANAGER’S COMMENTS:

City Manager Jonathan Greene offered comments.

ADJOURNMENT:

No further business being offered, a motion to adjourn was made by Councilmember Dancy, seconded by Councilmember Gunn. Vote was done by voice with all in favor. Mayor Mahoney adjourned the meeting at 8:52 p.m.

MEMO TO: Mayor and City Councilmembers
FROM: Andrea Muray, City Clerk
DATE: July 11, 2023
SUBJECT: Recognition of Jackson Area Hockey Association as a Nonprofit Organization

Recommendation:

Consideration of a resolution recognizing Jackson Area Hockey Association as a Nonprofit Organization operating in the community for the purpose of obtaining Charitable Gaming License through the State of Michigan.

The State of Michigan requires Charitable Gaming License applicants be recognized as a Nonprofit Organization by the local governing unit in order for the application to be considered. The Jackson Area Hockey Association currently has a provisional license. The State will consider issuing a permanent license upon receipt of a Council approved resolution.

Attached is the resolution recognizing Jackson Area Hockey Association as a nonprofit organization in the community for the purpose of obtaining a Raffle License.

Your consideration and concurrence is appreciated.

Attachment



Charitable Gaming Division
 Box 30023, Lansing, MI 48909
 OVERNIGHT DELIVERY:
 101 E. Hillsdale, Lansing MI 48933
 (517) 335-5780
 www.michigan.gov/cg

LOCAL GOVERNING BODY RESOLUTION FOR CHARITABLE GAMING LICENSES
 (Required by MCL.432.103(K)(ii))

At a Regular meeting of the Jackson City Council
REGULAR OR SPECIAL TOWNSHIP, CITY, OR VILLAGE COUNCIL/BOARD

called to order by Mayor Daniel Mahoney on July 11, 2023
DATE

at 6:30 p.m. a.m./p.m. the following resolution was offered:
TIME

Moved by _____ and supported by _____

that the request from Jackson Area Hockey Association of Jackson,
NAME OF ORGANIZATION CITY

county of Jackson, asking that they be recognized as a
COUNTY NAME

nonprofit organization operating in the community for the purpose of obtaining charitable

gaming licenses, be considered for _____.
APPROVAL/DISAPPROVAL

APPROVAL

DISAPPROVAL

Yeas: _____

Yeas: _____

Nays: _____

Nays: _____

Absent: _____

Absent: _____

I hereby certify that the foregoing is a true and complete copy of a resolution offered and
 adopted by the _____ at a _____
TOWNSHIP, CITY, OR VILLAGE COUNCIL/BOARD REGULAR OR SPECIAL

meeting held on _____.
DATE

SIGNED: _____
TOWNSHIP, CITY, OR VILLAGE CLERK

PRINTED NAME AND TITLE

ADDRESS

COMPLETION: Required.
 PENALTY: Possible denial of application.
 BSL-CG-1152/02/00

MEMO TO: Honorable Mayor and City Councilmembers
FROM: Andrea Muray, City Clerk
DATE: July 11, 2023
SUBJECT: Local Governmental Unit Approval for Social District Permit

RECOMMENDATION:

Consideration of a resolution approving the Social District Permit Application for Randu Inc. D/B/A, Tilted. Approval by Council is required in order for the State of Michigan Liquor Control Commission to consider their application.

On December 13, 2022 Council adopted Resolution No. 2022-76 approving the continuation of the Downtown Social District.

Your consideration is appreciated.

C: Jonathan Greene, City Manager



Local Governmental Unit Approval For Social District Permit

Instructions for Governing Body of Local Governmental Unit:

A qualified licensee that wishes to apply for a Social District Permit must first obtain approval from the governing body of the local governmental unit where the licensee is located and for which the local governmental unit has designated a social district with a commons area that is clearly marked and shared by and contiguous to the licensed premises of at least two (2) qualified licensees, pursuant to MCL 436.1551. Complete this resolution or provide a resolution, along with certification from the clerk or adopted minutes from the meeting at which this request was considered.

At a _____ meeting of the _____ council/board
(regular or special) (name of city, township, or village)

called to order by _____ on _____ at _____
(date) (time)

the following resolution was offered:

Moved by _____ and supported by _____

that the application from RANDU INC D/B/A TILTED
(name of licensee - if a corporation or limited liability company, please state the company name)

for a Social District Permit is _____ by this body for consideration for approval by the
(recommended/not recommended)
Michigan Liquor Control Commission.

If not recommended, state the reason: _____

Vote

Yeas: _____

Nays: _____

Absent: _____

I hereby certify that the foregoing is true and is a complete copy of the resolution offered and adopted by the _____
council/board at a _____ meeting held on _____
(regular or special) (date) (name of city, township, or village)

I further certify that the licensed premises of the aforementioned licensee are contiguous to the commons area designated by the council/board as part of a social district pursuant to MCL 436.1551.

Print Name of Clerk

Signature of Clerk

Date

Under Article IV, Section 40, of the Constitution of Michigan (1963), the Commission shall exercise complete control of the alcoholic beverage traffic within this state, including the retail sales thereof, subject to statutory limitations. Further, the Commission shall have the sole right, power, and duty to control the alcoholic beverage traffic and traffic in other alcoholic liquor within this state, including the licensure of businesses and individuals.

MEMO TO: Mayor and City Council Members
FROM: Jonathan Greene, City Manager
DATE: July 11, 2023
SUBJECT: Special Event Application: Jackson Hispanic Heritage Festival

Recommendation:

Approve a request from Nuestra Comunidad to host their Jackson Hispanic Heritage Festival event on September 16, 2023 in Horace Blackman Park, the True Community Credit Union City Square, and on the streets of downtown Jackson.

Attached is a memo and supporting paperwork from Jacqueline Austin regarding the Special Event Application for the Jackson Hispanic Heritage Festival.

I recommend approval of the special event application for the Jackson Hispanic Heritage Festival. Your consideration and concurrence is appreciated.

JG

DEPARTMENTAL REPORT

MEMO TO: Jonathan Greene, City Manager

FROM: Jacqueline Austin, Interim Director, DDA

DATE: June 11, 2023

RECOMMENDATION: Approve a request from Nuestra Comunidad to host their Jackson Hispanic Heritage Festival event on September 16, 2023 in Horace Blackman Park, the True Community Credit Union City Square, and on the streets of downtown Jackson.

SUMMARY: Community event celebrating and inviting the Hispanic and Latino population to come enjoy festivities, music, authentic cuisine, community resources and much more.

DEPARTMENTAL APPROVAL SUMMARY

Approvals noted below by each department indicate they have been made aware of the request and the capacity of their department has been met. Conditions of their approval and special considerations are noted.

<u>DEPARTMENT</u>	<u>APPROVAL</u>	<u>DENIAL</u>	<u>ECONOMIC IMPACT</u>
DDA	X		\$0.00
Engineering	X		\$0.00
Fire	X		\$0.00
Community Development	X		\$0.00
Parks & Recreation	X		\$0.00
Police	X		\$100.00
Public Works	X		\$400.00
	<i>TOTAL</i>		<i>\$500.00</i>

CONDITIONS & CONSIDERATIONS

Road closures, electricity

INSURANCE STATUS

Approved pending receipt of certificate of insurance

ATTACHMENTS: Special Event Application: Jackson Hispanic Heritage Festival



City of Jackson Downtown Development Authority
 161 W Michigan Ave, Jackson Michigan, MI 49201
 Contact for questions at 517-768-6411 or aecon@cityofjackson.org

SPECIAL EVENT APPLICATION

Application must be submitted 60 days PRIOR to event

Application Attachments

- | | |
|-------------------------------------------------------------------------------|--------------------------------------------------------------------------------------|
| <input checked="" type="checkbox"/> \$50 Application Fee | <input type="checkbox"/> Liquor License & Liquor Liability Insurance (if applicable) |
| <input type="checkbox"/> \$25 Late/Rush Fee | <input type="checkbox"/> Carnival Ride Permit (if applicable) |
| <input type="checkbox"/> Insurance documentation for sponsoring organization | <input type="checkbox"/> Insurance documentation for all vendors (if applicable) |
| <input type="checkbox"/> Event Map –Please indicate the location of all items | |

Make checks payable to "Downtown Development Authority"

Special Event Application Policy

Additional charges may occur if policies are broken.

1. The applicant or representative of any business, group, or organization that seeks approval to conduct a special event must be 21 years of age or older.
2. No ground stakes are allowed on City property. Tents and inflatables must be weighted down.
3. Glitter and confetti are prohibited at all events.
4. No plugging into outlets without prior approval.
5. For events utilizing street space, all fixtures (tents, vehicles, trucks, etc.) must be placed near the curbs to allow for emergency vehicle access.
6. No alcoholic beverages allowed unless proper paperwork is provided along with City Council approval. Alcoholic beverages must be consumed within the area in which they are served. No containers, open or closed, may leave the event area unless approval is granted.
7. Only a removable medium, such as chalk and/or tape, can be used to mark event area or routes. No paint of any kind is permitted. Tape must be removed once event is over.
8. One temporary sign/banner is permitted with your event, provided it measures no more than 12 ft² and does not block any intersections, driveways, or right-of-ways.

Applicant Information

Sponsoring Organization Legal Name: Nuestra Comunidad	
Address: 608 N. State St.	Phone: (517) 962-3614
Tax ID#: 92-3256932	Website:
Contact Name: Leticia Albarran	Phone: 517-962-3614 Email: lalbarran08@gmail.com
Contact Name: Jacob Inosencio	Phone: 517-745-9805 Email: jwinosencio@gmail.com
Contact Name During Event: Jacob Inosencio	Phone: (517) 745-9805

Event Information

Event Name: Jackson Hispanic Heritage Festival				
Event Date(s):	Set up Time:	Start Time:	End Time:	Tear Down Time:
9/16/2023	9:00 AM	12:00 PM	9:30 PM	10:00 PM

Has this event occurred before? Yes, (if yes, how many previous years? 1 year) No

Do you expect this event to occur again next year? yes What is the expected attendance for this event? 1,000

Type of Event (please check all that apply)

Walk/Run Festival March/Parade Other: _____

Event Location – Choose any of the following that apply. For parks, include a map of the area being used.

Horace Blackman Park GrandRiver Farmers Market Pavilion
 Bucky Harris Park TRUE City Square (Stage)
 Ella Sharp Park (requires Ella Sharp Board approval) MLK Equality Trail
 Other Location: _____
 Streets: See Street Closure
 Other Park: _____

Brief description of Event

This description will be posted on the Special Events Calendar on our website. Please attach an additional sheet if necessary.

JHHF is a festival celebrating and inviting the Hispanic/Latino population in Jackson and surrounding cities. Vendors, community organizations, and small businesses will be offering authentic Latin American cuisine, access to community resources, live entertainment and music, raffles, and youth activities.

Street Closure– Please indicate all street closures on your map.

Street Name: W. Michigan Ave Cross Streets N. Jackson + W. Michigan Ave
Closure Start Date: 9/16/23 Time: 8:00AM Closure End Date: 9/16/23 Time: 11:30pm
Street Name: W. Michigan Ave Cross Streets N. Blackstone + W. Michigan
Closure Start Date: 9/16/23 Time: 8:00AM Closure End Date: 9/16/23 Time: 11:30pm
Street Name: _____ Cross Streets _____
Closure Start Date: _____ Time: _____ Closure End Date: _____ Time: _____
Street Name: _____ Cross Streets _____
Closure Start Date: _____ Time: _____ Closure End Date: _____ Time: _____
Street Name: _____ Cross Streets _____
Closure Start Date: _____ Time: _____ Closure End Date: _____ Time: _____
Street Name: _____ Cross Streets _____
Closure Start Date: _____ Time: _____ Closure End Date: _____ Time: _____

City Resources Requests

Not all resources may be available at your requested site.

Please be specific and list any additional information or requests. Such requests might include assistance from the Police Department, Fire Department, Parks and Recreation Department, Public Works Department, etc. Attach additional pages, if needed.

Electrical Power: Indicate electrical requirements: _____
 Amount of electrical wattage needed: _____ Amount of plug ins: 17
 Locations of where plugs are needed: _____
****All electrical lines MUST be covered to limit tripping hazards.****

Water Needs: Indicate water requirements: _____
 Amount of water needed: _____ Locations of where water is needed: _____

Food/Vendors: Indicate vendors requirements: Electricity
 Amount of electrical wattage needed: _____ Amount of plug ins: _____
 Locations of where plugs are needed: _____ Number of vendors: _____

Alcohol Sales: (If yes attach liquor license and liquor liability insurance)
 Start Time: _____ End Time: _____

Amusement or Carnival Rides: If yes indicate electrical requirements: _____
 Amount of electrical wattage needed: _____ Amount of plug ins: _____
 Locations of where plugs are needed: _____

Fireworks: If yes indicate electrical requirements: _____
 Amount of electrical wattage needed: _____ Amount of plug ins: _____
 Locations of where plugs are needed: _____

Traffic Cones Mobile Stage (please circle **15-foot** or **25-foot** version)

Other: _____

Insurance

Please request the following documentation from your insurance carrier.

Insurance Type	Requirements
<p style="color: blue;">COI will be issued closer to the date of the event</p> <p>Certificate of Liability Insurance (MUST also be provided by all vendors)</p>	<ul style="list-style-type: none"> Showing a liability coverage of at least \$1,000,000 Identifying "City of Jackson" & " Jackson Downtown Development Authority as additional insured
<p>Liquor Liability Insurance (if needed)</p>	<ul style="list-style-type: none"> Identifying "City of Jackson" & "Jackson Downtown Development Authority" as additional insured
<p>XCU Fireworks Liability Insurance (if needed; required for all fireworks displays)</p>	<ul style="list-style-type: none"> Identifying "City of Jackson" & "Jackson Downtown Development Authority" as additional insured

I am a Level 1 Special Event (low resources), and would like to be considered for eligibility to enter a Hold Harmless Agreement with The City of Jackson in lieu of providing the above-required insurance documentation.

Event Map Details of all event activities MUST be included.

<input type="checkbox"/> Route Plan <input checked="" type="checkbox"/> Vendor Locations <input checked="" type="checkbox"/> Tent Locations <input type="checkbox"/> Assembly Locations	<input type="checkbox"/> Emergency Vehicle Access <input type="checkbox"/> Dispersal Locations <input type="checkbox"/> Trash Receptacles <input type="checkbox"/> Requested Street Closures	<input type="checkbox"/> Restroom Locations <input type="checkbox"/> Tables <input type="checkbox"/> Requested Reserved Parking <input type="checkbox"/> Electrical Wires & Outlets
--------------------------------------------------------------------------------------------------------------------------------------------------------------------------------------------------	-------------------------------------------------------------------------------------------------------------------------------------------------------------------------------------------------------	----------------------------------------------------------------------------------------------------------------------------------------------------------------------------------------------

*If these details change, a revised map must be provided seven days prior to event.
 Revised maps cannot include any additional street use, reserved parking, or additional space reservations.*

Special Event Application

Certification & Signature

1. I am the person with authority to act on behalf of the sponsoring organization.
2. I have submitted all required documents in support of the Special Event application
3. A Special Event Application Fee is submitted along with this application.
4. Only the activities listed on the application will be permitted at the event. If additional activities are added, I will immediately contact the City of Jackson. I understand that the approval of my application may be withdrawn or additional action required.
5. All food vendors must be approved by the Jackson County Health Department and each food and other vendor must provide the City of Jackson with a Certificate of Insurance which names the City of Jackson and the Downtown Development Authority as additional insured parties on the policy.
6. Fire Department permit and approval is required for events including display fireworks. Extreme Close-Up (XCU) fireworks liability insurance is required for all fireworks display.
7. The approval of this special event may include additional requirements, limitations, or fees based on the City's review of the application.
8. If I, or my organization, fail to clean up and repair damages to the event area, my organization may be billed for City services, and that failure to clean up and repair damage will be considered for future applications.
9. As the duly authorized agent of the sponsoring organization applying for approval of the Special Event, I affirm the above understandings and agree that my sponsoring organization will comply with the terms of the written confirmation of approval and all City requirements, ordinances and other laws which apply to this Special Event.
10. By signing this Special Event Application, I declare I am 21 years of age or older.
11. If required to provide liability insurance, the sponsoring organization will add the City of Jackson and the Downtown Development Authority as additional insured parties on the sponsoring organization's liability policy.
12. On behalf of the sponsoring organization, I agree that the sponsoring organization will defend, indemnify, and hold harmless the City of Jackson, its officers, employees and agents from and against any claim, demand, suit, loss, cost or expense, or any damage, which may be asserted, claimed, or recovered against or from the City of Jackson, its officers, employees, and agent, by reason of any damage to property, bodily injury, or death, sustained by any person whomsoever, and which damage, injury, or death arises out of or is incident to or in any way connected with or related to this Special Event.
13. The City of Jackson reserves the right to waive any requirements of this policy in the interests of the health, safety, and welfare of the citizens of Jackson.

Signature: _____

Date: 5-1-23

Office Use ONLY	
Application Received:	
Date:	<u>5-1-23</u>
Time:	<u>3PM</u>
By:	<u>DCS</u>
Application Fee Received:	<u>50 CASH</u>

Application Requirements
Application MUST be submitted 60 days PRIOR to event ***NO EXCEPTIONS***
Application MUST be submitted along with all required attachments to: City of Jackson Downtown Development Authority Office 161 W Michigan Ave, 5 th Floor Jackson Michigan, MI 49201 or aecon@cityofjackson.org (517) 768-6411
Prohibited Items
<i>Additional fees may apply if policies are not followed</i>
No ground stakes No confetti or glitter No use of outlets without prior approval





Only After 5pm

MEMO TO: Mayor and City Council Members
FROM: Jonathan Greene, City Manager
DATE: July 11, 2023
SUBJECT: Special Event Application: Relay for Life

Recommendation:

Approve a request from the American Cancer Society to host their Relay for Life event July 28-29, 2023, in and around Sparks Foundation Park.

Attached is a memo and supporting paperwork from Jacqueline Austin regarding the Special Event Application for Relay for Life.

I recommend approval of the special event application for Relay for Life. Your consideration and concurrence is appreciated.

JG

DEPARTMENTAL REPORT

MEMO TO: Jonathan Greene, City Manager

FROM: Jacqueline Austin, Interim Director, DDA

DATE: June 11, 2023

RECOMMENDATION: Approve a request from the American Cancer Society to host their Relay for Life event July 28-29, 2023, in and around Sparks Foundation Park.

SUMMARY: An event that brings the community together to fight back against cancer

DEPARTMENTAL APPROVAL SUMMARY

Approvals noted below by each department indicate they have been made aware of the request and the capacity of their department has been met. Conditions of their approval and special considerations are noted.

<u>DEPARTMENT</u>	<u>APPROVAL</u>	<u>DENIAL</u>	<u>ECONOMIC IMPACT</u>
DDA	X		\$0.00
Engineering	X		\$0.00
Fire	X		\$0.00
Community Development	X		\$0.00
Parks & Recreation	X		\$0.00
Police	X		\$0.00
Public Works	X		\$1200.00
	<i>TOTAL</i>		<i>\$1200.00</i>

CONDITIONS & CONSIDERATIONS

Electricity; city stage on wheels, light towers

INSURANCE STATUS

Current and on-file with the City Attorney and Downtown Development Authority

ATTACHMENTS: Special Event Application: Relay for Life

SPECIAL EVENT APPLICATION

Application must be submitted 60 days PRIOR to event

Application Attachments

- | | |
|-------------------------------------------------------------------------------|--------------------------------------------------------------------------------------|
| <input checked="" type="checkbox"/> \$50 Application Fee | <input type="checkbox"/> Liquor License & Liquor Liability Insurance (if applicable) |
| <input type="checkbox"/> \$25 Late/Rush Fee | <input type="checkbox"/> Carnival Ride Permit (if applicable) |
| <input type="checkbox"/> Insurance documentation for sponsoring organization | <input type="checkbox"/> Insurance documentation for all vendors (if applicable) |
| <input type="checkbox"/> Event Map –Please indicate the location of all items | |

Make checks payable to “Downtown Development Authority”

Special Event Application Policy

Additional charges may occur if policies are broken.

- The applicant or representative of any business, group, or organization that seeks approval to conduct a special event must be 21 years of age or older.
- No ground stakes are allowed on City property. Tents and inflatables must be waited down.
- Glitter and confetti are prohibited at all events.
- No plugging into outlets without prior approval.
- For events utilizing street space, all fixtures (tents, vehicles, trucks, etc.) must be placed near the curbs to allow for emergency vehicle access.
- No alcoholic beverages allowed unless proper paperwork is provided along with City Council approval. Alcoholic beverages must be consumed within the area in which they are served. No containers, open or closed, may leave the event area unless approval is granted.
- Only a removable medium, such as chalk and/or tape, can be used to mark event area or routes. No paint of any kind is permitted. Tape must be removed once event is over.

Applicant Information

Sponsoring Organization Legal Name: American Cancer Society, Inc.	
Address: PO Box 10069, Detroit, MI 48210	Phone: (517) 325.2272
Tax ID#: 13-1788491	Website: RelayForLife.org/JacksonCountyMI
Contact Name: Katie Jones	Phone: 517.325.2272 Email: katie.jones@cancer.org
Contact Name:	Phone: Email:
Contact Name During Event: Katie Jones	Phone: (269) 967.1762

Event Information

Event Name: Relay For Life of Jackson County				
Event Date(s):	Event Set up Time:	Event Start Time:	Event End Time:	Event Tear Down Time:
7/28/23 - 7/29/23	8am (7/28)	4pm (7/28)	2pm (7/29)	2pm (7/29)

Has this event occurred before? Yes, (if yes, how many previous years? 32 years) No

Do you expect this event to occur again next year? yes What is the expected attendance for this event? 1,000

Type of Event (please check all that apply)

Walk/Run Festival March/Parade Other: Walk in a loop with activities/campsites around loop

Event Location – Choose any of the following that apply. For parks, include a map of the area being used.

- | | |
|-------------------------------------------------------------------------------|-------------------------------------------------------------|
| <input type="checkbox"/> Horace Blackman Park | <input type="checkbox"/> GrandRiver Farmers Market Pavilion |
| <input type="checkbox"/> Bucky Harris Park | <input type="checkbox"/> CP Federal City Square (Stage) |
| <input type="checkbox"/> Ella Sharp Park (requires Ella Sharp Board approval) | <input type="checkbox"/> MLK Equality Trail |
| <input type="checkbox"/> Other Location: _____ | |
| <input checked="" type="checkbox"/> Streets: <u>Randolph Street</u> | |
| <input checked="" type="checkbox"/> Other Park: <u>Cascades Park</u> | |

Brief description of Event

This description will be posted on the Special Events Calendar on our website. Please attach an additional sheet if necessary.

The American Cancer Society's Relay For Life brings the community together to fight back against cancer. Individuals, teams, and survivors rally together. One member of each team is walking the Relay track throughout the event.

Street Closure– Please indicate all street closures on your map.

Street Name: <u>Randolph Street</u>	Cross Streets <u>Between Brown St. and W High St.</u>
Closure Start Date: <u>7/28/23</u> Time: <u>8am</u>	Closure End Date: <u>7/29/23</u> Time: <u>4pm</u>
Street Name: _____	Cross Streets _____
Closure Start Date: _____ Time: _____	Closure End Date: _____ Time: _____
Street Name: _____	Cross Streets _____
Closure Start Date: _____ Time: _____	Closure End Date: _____ Time: _____
Street Name: _____	Cross Streets _____
Closure Start Date: _____ Time: _____	Closure End Date: _____ Time: _____
Street Name: _____	Cross Streets _____
Closure Start Date: _____ Time: _____	Closure End Date: _____ Time: _____

City Resources Requests

Not all resources may be available at your requested site.

Please be specific and list any additional information or requests. Such requests might include assistance from the Police Department, Fire Department, Parks and Recreation Department, Public Works Department, etc. Attach additional pages, if needed.

- Electrical Power:** Indicate electrical requirements: working with consumers Energy as in the past
 Amount of electrical wattage needed: _____ Amount of plug ins: _____
 Locations of where plugs are needed: _____
****All electrical lines MUST be covered to limit tripping hazards. ****
- Water Needs:** Indicate water requirements: _____
 Amount of water needed: _____ Locations of where water is needed: _____
- Food/Vendors:** Indicate vendors requirements: _____
 Amount of electrical wattage needed: _____ Amount of plug ins: _____
 Locations of where plugs are needed: _____ Number of vendors: _____
- Alcohol Sales:** (If yes attach liquor license and liquor liability insurance)
 Start Time: _____ End Time: _____
- Amusement or Carnival Rides:** If yes indicate electrical requirements: _____
 Amount of electrical wattage needed: _____ Amount of plug ins: _____
 Locations of where plugs are needed: _____
- Fireworks:** If yes indicate electrical requirements: _____
 Amount of electrical wattage needed: _____ Amount of plug ins: _____
 Locations of where plugs are needed: _____
- Traffic Cones Mobile Stage (please circle 15-foot or 25-foot version)
- Other:** Use of light tower to be placed Randolph St. and W. High St. Proximity.

Insurance

Please request the following documentation from your insurance carrier.

Insurance Type	Requirements
Certificate of Liability Insurance <i>(MUST also be provided by all vendors)</i>	<ul style="list-style-type: none"> Showing a liability coverage of at least \$1,000,000 Identifying "City of Jackson" & "Jackson Downtown Development Authority" as additional insured
Liquor Liability Insurance <i>(if needed)</i>	<ul style="list-style-type: none"> Identifying "City of Jackson" & "Jackson Downtown Development Authority" as additional insured
XCU Fireworks Liability Insurance <i>(if needed; required for all fireworks displays)</i>	<ul style="list-style-type: none"> Identifying "City of Jackson" & "Jackson Downtown Development Authority" as additional insured

- I am a Level I Special Event (low resources), and would like to be considered for eligibility to enter a Hold Harmless Agreement with The City of Jackson in lieu of providing the above-required insurance documentation.

Event Map *Details of all event activities MUST be included.*

- | | | |
|---------------------------------------------|----------------------------------------------------|-----------------------------------------------------|
| <input type="checkbox"/> Route Plan | <input type="checkbox"/> Emergency Vehicle Access | <input type="checkbox"/> Restroom Locations |
| <input type="checkbox"/> Vendor Locations | <input type="checkbox"/> Dispersal Locations | <input type="checkbox"/> Tables |
| <input type="checkbox"/> Tent Locations | <input type="checkbox"/> Trash Receptacles | <input type="checkbox"/> Requested Reserved Parking |
| <input type="checkbox"/> Assembly Locations | <input type="checkbox"/> Requested Street Closures | <input type="checkbox"/> Electrical Wires & Outlets |

*If these details change, a revised map must be provided seven days prior to event.
 Revised maps cannot include any additional street use, reserved parking, or additional space reservations.*

Special Event Application

Certification & Signature

1. I am the person with authority to act on behalf of the sponsoring organization.
2. I have submitted all required documents in support of the Special Event application
3. A Special Event Application Fee is submitted along with this application.
4. Only the activities listed on the application will be permitted at the event. If additional activities are added, I will immediately contact the City of Jackson. I understand that the approval of my application may be withdrawn or additional action required.
5. All food vendors must be approved by the Jackson County Health Department and each food and other vendor must provide the City of Jackson with a Certificate of Insurance which names the City of Jackson and the Downtown Development Authority as additional insured parties on the policy.
6. Fire Department permit and approval is required for events including display fireworks. Extreme Close-Up (XCU) fireworks liability insurance is required for all fireworks display.
7. The approval of this special event may include additional requirements, limitations, or fees based on the City's review of the application.
8. If I, or my organization, fail to clean up and repair damages to the event area, my organization may be billed for City services, and that failure to clean up and repair damage will be considered for future applications.
9. As the duly authorized agent of the sponsoring organization applying for approval of the Special Event, I affirm the above understandings and agree that my sponsoring organization will comply with the terms of the written confirmation of approval and all City requirements, ordinances and other laws which apply to this Special Event.
10. By signing this Special Event Application, I declare I am 21 years of age or older.
11. If required to provide liability insurance, the sponsoring organization will add the City of Jackson and the Downtown Development Authority as additional insured parties on the sponsoring organization's liability policy.
12. On behalf of the sponsoring organization, I agree that the sponsoring organization will defend, indemnify, and hold harmless the City of Jackson, its officers, employees and agents from and against any claim, demand, suit, loss, cost or expense, or any damage, which may be asserted, claimed, or recovered against or from the City of Jackson, its officers, employees, and agent, by reason of any damage to property, bodily injury, or death, sustained by any person whomsoever, and which damage, injury, or death arises out of or is incident to or in any way connected with or related to this Special Event.
13. The City of Jackson reserves the right to waive any requirements of this policy in the interests of the health, safety, and welfare of the citizens of Jackson.

Signature: Katie Jones

Date: 1/10/2023

Office Use ONLY	
Application Received:	
Date:	1/11/2023
Time:	AE
By:	
Application Fee Received:	<input checked="" type="checkbox"/> yes

Application Requirements
Application MUST be submitted 60 days PRIOR to event ***NO EXCEPTIONS***
Application MUST be submitted along with all required attachments to: City of Jackson Downtown Development Authority Office 161 W Michigan Ave, 5 th Floor Jackson Michigan, MI 49201 or cmays@cityofjackson.org (517) 768-6410
Prohibited Items
Additional fees may apply if policies are not followed
No ground stakes No confetti or glitter No use of outlets without prior approval

Track layout!

- Old road
- The road is no longer there.

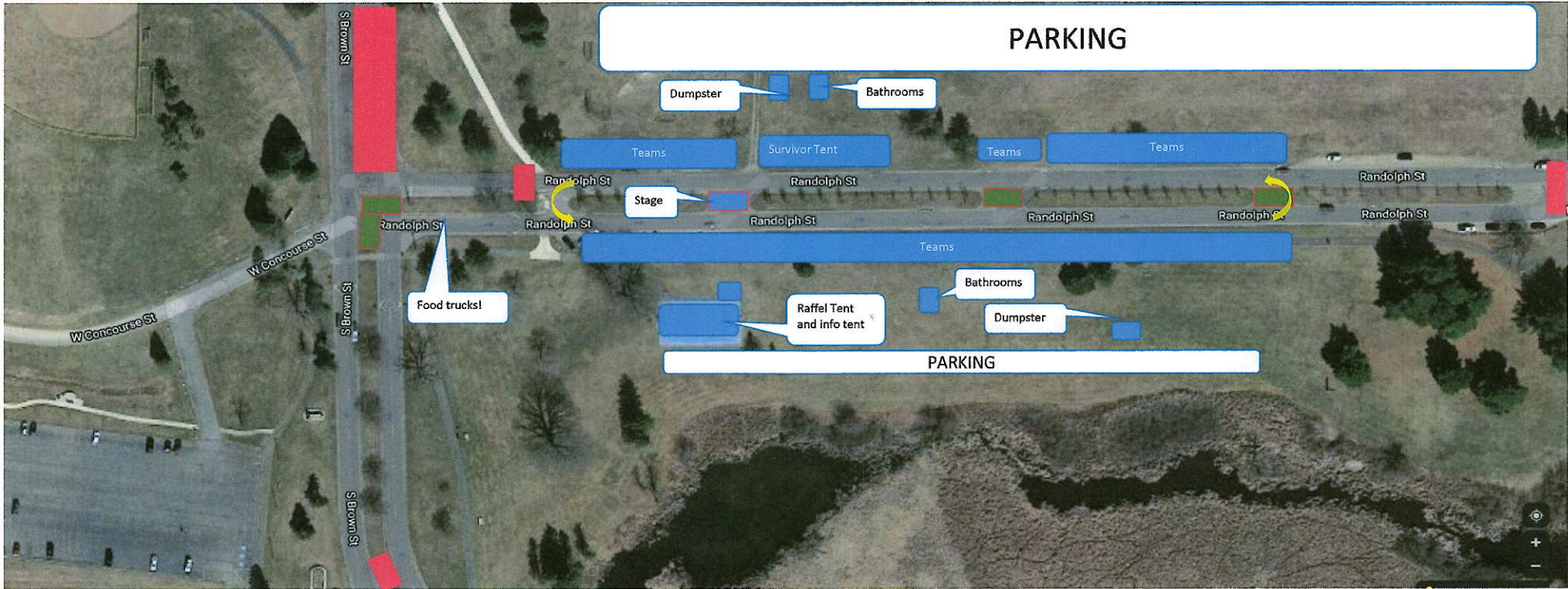

**CERTIFICATE OF LIABILITY INSURANCE**

DATE (MM/DD/YYYY)

6/7/2023

THIS CERTIFICATE IS ISSUED AS A MATTER OF INFORMATION ONLY AND CONFERS NO RIGHTS UPON THE CERTIFICATE HOLDER. THIS CERTIFICATE DOES NOT AFFIRMATIVELY OR NEGATIVELY AMEND, EXTEND OR ALTER THE COVERAGE AFFORDED BY THE POLICIES BELOW. THIS CERTIFICATE OF INSURANCE DOES NOT CONSTITUTE A CONTRACT BETWEEN THE ISSUING INSURER(S), AUTHORIZED REPRESENTATIVE OR PRODUCER, AND THE CERTIFICATE HOLDER.

IMPORTANT: If the certificate holder is an ADDITIONAL INSURED, the policy(ies) must have ADDITIONAL INSURED provisions or be endorsed. If SUBROGATION IS WAIVED, subject to the terms and conditions of the policy, certain policies may require an endorsement. A statement on this certificate does not confer rights to the certificate holder in lieu of such endorsement(s).

PRODUCER Commercial Lines – (404) 923-3700 USI Insurance Services LLC 1 Concourse Parkway NE, Suite 700 Atlanta, GA 30328	CONTACT NAME: Jennifer Lefler PHONE (A/C, No, Ext): 470-875-0441 E-MAIL ADDRESS: jennifer.lefler@usi.com	FAX (A/C, No): 610-537-1929	
	INSURER(S) AFFORDING COVERAGE		NAIC #
INSURED American Cancer Society, Inc. 3380 Chastain Meadows Pkwy. NW Suite 200 Kennesaw, GA 30144-0101	INSURER A: ACE American Insurance Company		22667
	INSURER B:		
	INSURER C:		
	INSURER D:		
	INSURER E:		
	INSURER F:		

COVERAGES**CERTIFICATE NUMBER:** 15734556**REVISION NUMBER:** See below

THIS IS TO CERTIFY THAT THE POLICIES OF INSURANCE LISTED BELOW HAVE BEEN ISSUED TO THE INSURED NAMED ABOVE FOR THE POLICY PERIOD INDICATED. NOTWITHSTANDING ANY REQUIREMENT, TERM OR CONDITION OF ANY CONTRACT OR OTHER DOCUMENT WITH RESPECT TO WHICH THIS CERTIFICATE MAY BE ISSUED OR MAY PERTAIN, THE INSURANCE AFFORDED BY THE POLICIES DESCRIBED HEREIN IS SUBJECT TO ALL THE TERMS, EXCLUSIONS AND CONDITIONS OF SUCH POLICIES. LIMITS SHOWN MAY HAVE BEEN REDUCED BY PAID CLAIMS.

INSR LTR	TYPE OF INSURANCE	ADDL INSD	SUBR WVD	POLICY NUMBER	POLICY EFF (MM/DD/YYYY)	POLICY EXP (MM/DD/YYYY)	LIMITS	
A	<input checked="" type="checkbox"/> COMMERCIAL GENERAL LIABILITY <input type="checkbox"/> CLAIMS-MADE <input checked="" type="checkbox"/> OCCUR GEN'L AGGREGATE LIMIT APPLIES PER: <input checked="" type="checkbox"/> POLICY <input type="checkbox"/> PRO-JECT <input checked="" type="checkbox"/> LOC <input checked="" type="checkbox"/> OTHER: Event	X		HDO G47299081	09/01/2022	09/01/2023	EACH OCCURRENCE	\$ 1,000,000
							DAMAGE TO RENTED PREMISES (Ea occurrence)	\$ 300,000
							MED EXP (Any one person)	\$ 2,500
							PERSONAL & ADV INJURY	\$ 1,000,000
							GENERAL AGGREGATE	\$ 25,000,000
							PRODUCTS - COMP/OP AGG	\$ 2,000,000
								\$
	AUTOMOBILE LIABILITY <input type="checkbox"/> ANY AUTO <input type="checkbox"/> OWNED AUTOS ONLY <input type="checkbox"/> HIRED AUTOS ONLY <input type="checkbox"/> SCHEDULED AUTOS <input type="checkbox"/> NON-OWNED AUTOS ONLY						COMBINED SINGLE LIMIT (Ea accident)	\$
							BODILY INJURY (Per person)	\$
							BODILY INJURY (Per accident)	\$
							PROPERTY DAMAGE (Per accident)	\$
								\$
	UMBRELLA LIAB <input type="checkbox"/> OCCUR EXCESS LIAB <input type="checkbox"/> CLAIMS-MADE DED RETENTION \$						EACH OCCURRENCE	\$
							AGGREGATE	\$
								\$
	WORKERS COMPENSATION AND EMPLOYERS' LIABILITY ANY PROPRIETOR/PARTNER/EXECUTIVE OFFICER/MEMBER EXCLUDED? (Mandatory in NH) If yes, describe under DESCRIPTION OF OPERATIONS below						PER STATUTE	OTH-ER
							E.L. EACH ACCIDENT	\$
							E.L. DISEASE - EA EMPLOYEE	\$
							E.L. DISEASE - POLICY LIMIT	\$

DESCRIPTION OF OPERATIONS / LOCATIONS / VEHICLES (ACORD 101, Additional Remarks Schedule, may be attached if more space is required)

Re: Contract #92466
 Relay For Life of Jackson County
 Cascades Falls Park
 July 28- 29, 2023

The City of Jackson & the Jackson Downtown Development Authority is included as an additional insured in accordance with the terms and conditions of the General Liability policy and only if required by written contract or agreement.

CERTIFICATE HOLDER**CANCELLATION**

City of Jackson Downtown Development Authority
 161 W Michigan Ave
 Jackson Michigan, MI 49201

SHOULD ANY OF THE ABOVE DESCRIBED POLICIES BE CANCELLED BEFORE THE EXPIRATION DATE THEREOF, NOTICE WILL BE DELIVERED IN ACCORDANCE WITH THE POLICY PROVISIONS.

AUTHORIZED REPRESENTATIVE

Paul B. Blum

The ACORD name and logo are registered marks of ACORD © 1988-2015 ACORD CORPORATION. All rights reserved.

MEMO TO: Mayor and City Council Members
FROM: Jonathan Greene, City Manager
DATE: July 11, 2023
SUBJECT: Special Event Application: Veteran Suicide Prevention Ruck March

Recommendation:

Approve a request from the Jackson County Military Coalition to host their Veteran Suicide Prevention Ruck March on September 09, 2023, on the sidewalks/crosswalks of Jackson.

Attached is a memo and supporting paperwork from Jacqueline Austin regarding the Special Event Application for the Veteran Suicide Prevention Ruck March.

I recommend approval of the special event application for the Veteran Suicide Prevention Ruck March. Your consideration and concurrence is appreciated.

JG

DEPARTMENTAL REPORT

MEMO TO: Jonathan Greene, City Manager

FROM: Jacqueline Austin, Interim Director, DDA

DATE: September 09, 2023

RECOMMENDATION: Approve a request from the Jackson County Military Coalition to host their Veteran Suicide Prevention Ruck March on September 09, 2023, on the sidewalks/crosswalks of Jackson.

SUMMARY: Ruck march to raise awareness regarding veteran suicide and prevention.

DEPARTMENTAL APPROVAL SUMMARY

Approvals noted below by each department indicate they have been made aware of the request and the capacity of their department has been met. Conditions of their approval and special considerations are noted.

<u>DEPARTMENT</u>	<u>APPROVAL</u>	<u>DENIAL</u>	<u>ECONOMIC IMPACT</u>
DDA	X		\$0.00
Engineering	X		\$0.00
Fire	X		\$0.00
Community Development	X		\$0.00
Parks & Recreation	X		\$0.00
Police	X		\$0.00
Public Works	X		\$0.00
		<i>TOTAL</i>	<i>\$0.00</i>

CONDITIONS & CONSIDERATIONS

None

INSURANCE STATUS

Approved by the office of the City Attorney, pending receipt of copy of liability insurance

ATTACHMENTS: Special Event Application: Veteran Suicide Prevention Ruck March

SPECIAL EVENT APPLICATION

Application must be submitted 60 days PRIOR to event

Application Attachments

- | | |
|------------------------------------------------------------------------------------------|--------------------------------------------------------------------------------------|
| <input checked="" type="checkbox"/> \$50 Application Fee | <input type="checkbox"/> Liquor License & Liquor Liability Insurance (if applicable) |
| <input type="checkbox"/> \$25 Late/Rush Fee | <input type="checkbox"/> Carnival Ride Permit (if applicable) |
| <input checked="" type="checkbox"/> Insurance documentation for sponsoring organization | <input type="checkbox"/> Insurance documentation for all vendors (if applicable) |
| <input checked="" type="checkbox"/> Event Map –Please indicate the location of all items | |

Make checks payable to “Downtown Development Authority”

Special Event Application Policy

Additional charges may occur if policies are broken.

1. The applicant or representative of any business, group, or organization that seeks approval to conduct a special event must be 21 years of age or older.
2. No ground stakes are allowed on City property. Tents and inflatables must be weighted down.
3. Glitter and confetti are prohibited at all events.
4. No plugging into outlets without prior approval.
5. For events utilizing street space, all fixtures (tents, vehicles, trucks, etc.) must be placed near the curbs to allow for emergency vehicle access.
6. No alcoholic beverages allowed unless proper paperwork is provided along with City Council approval. Alcoholic beverages must be consumed within the area in which they are served. No containers, open or closed, may leave the event area unless approval is granted.
7. Only a removable medium, such as chalk and/or tape, can be used to mark event area or routes. No paint of any kind is permitted. Tape must be removed once event is over.
8. One temporary sign/banner is permitted with your event, provided it measures no more than 12 ft² and does not block any intersections, driveways, or right-of-ways.

Applicant Information

Sponsoring Organization Legal Name: Jackson County Military Coalition	
Address: 1203 1st St. Jackson MI 49203	Phone: (517) 257-1577
Tax ID#: GET FROM VITTORIA	Website: https://m.facebook.com/people/Jackson-County-Military-Coalition/100086685288556/?hc_ref=ARSgMKhrFFn2xpw
Contact Name: Douglas Brinker	Phone: 517-257-1577 Email: Douglas.Brinker@LifeWaysMi.Org
Contact Name: Darcy Herrera	Phone: 517-315-1530 Email: darcy.herrera@lifewaysmi.org
Contact Name During Event: Douglas Brinker	Phone: (517) 257-1577

Event Information

Event Name: Veteran Suicide Prevention Ruck March				
Event Date(s):	Set up Time:	Start Time:	End Time:	Tear Down Time:
09/09/2023	0800	0900	1300	1400

Has this event occurred before? Yes, (if yes, how many previous years? _____) No

Do you expect this event to occur again next year? Yes _____ What is the expected attendance for this event? ¹⁰⁰ _____

Type of Event (please check all that apply)

Walk/Run Festival March/Parade Other: _____

Event Location – Choose any of the following that apply. For parks, include a map of the area being used.

- Horace Blackman Park
- Bucky Harris Park
- Ella Sharp Park (requires Ella Sharp Board approval)
- Other Location: Sidewalks and Cross Walks
- GrandRiver Farmers Market Pavilion
- TRUE City Square (Stage)
- MLK Equality Trail

Streets: ~~Fairgrounds, W. on Ganson, S. on Steward, Merge to W. Washington Ave, S. on Blackstone, E. on Franklin, N. on Cooper, W. on Ganson. Return to Fairgrounds~~

Other Park: _____

Brief description of Event

This description will be posted on the Special Events Calendar on our website. Please attach an additional sheet if necessary.

The Jackson County Military Coalition is hosting the Veteran Suicide Prevention Ruck March to honor Veterans and Service Members who have died by suicide.

Street Closure– Please indicate all street closures on your map.

Street Name: E. Ganson from Steward to Cooper Cross Streets Steward and Cooper
Closure Start Date: 09/09/2023 Time: 0800 Closure End Date: 09/09/2023 Time: 1300
Street Name: Steward Ave from E. Ganson & Blackstone Cross Streets E. Ganson & Blackstone
Closure Start Date: 09/09/2023 Time: 0800 Closure End Date: 09/09/2023 Time: 1300
Street Name: N. Blackstone from Washington & Franklin Cross Streets W. Washington & E. Franklin
Closure Start Date: 09/09/2023 Time: 0800 Closure End Date: 09/09/2023 Time: 1300
Street Name: E. Franklin from Blackstone to Cooper Cross Streets N. Blackstone and S. Cooper
Closure Start Date: 09/09/2023 Time: 0800 Closure End Date: 09/09/2023 Time: 1300
Street Name: S. Cooper from E. Franklin to E. Ganson Cross Streets E. Franklin and E. Ganson
Closure Start Date: 09/09/2023 Time: 0800 Closure End Date: 09/09/2023 Time: 1300
Street Name: N. Jackson St from E. Ganson to Fairgrounds Cross Streets E. Ganson
Closure Start Date: 09/09/2023 Time: 0800 Closure End Date: 09/09/2023 Time: 1300

No street closures. Jackson County Military Coalition has decided to use sidewalks & crosswalks for their ruck march.

City Resources Requests

Not all resources may be available at your requested site.

Please be specific and list any additional information or requests. Such requests might include assistance from the Police Department, Fire Department, Parks and Recreation Department, Public Works Department, etc. Attach additional pages, if needed.

Electrical Power: Indicate electrical requirements: _____
 Amount of electrical wattage needed: _____ Amount of plug ins: _____
 Locations of where plugs are needed: _____
****All electrical lines MUST be covered to limit tripping hazards. ****

Water Needs: Indicate water requirements: _____
 Amount of water needed: _____ Locations of where water is needed: _____

Food/Vendors: Indicate vendors requirements: food trucks; no additional needs
 Amount of electrical wattage needed: _____ Amount of plug ins: _____
 Locations of where plugs are needed: _____ Number of vendors: 1-4

Alcohol Sales: (If yes attach liquor license and liquor liability insurance)
 Start Time: _____ End Time: _____

Amusement or Carnival Rides: If yes indicate electrical requirements: _____
 Amount of electrical wattage needed: _____ Amount of plug ins: _____
 Locations of where plugs are needed: _____

Fireworks: If yes indicate electrical requirements: _____
 Amount of electrical wattage needed: _____ Amount of plug ins: _____
 Locations of where plugs are needed: _____

Traffic Cones Mobile Stage (please circle **15-foot** or **25-foot** version)
 Other: _____

Insurance

Please request the following documentation from your insurance carrier.

Insurance Type	Requirements
Certificate of Liability Insurance <i>(MUST also be provided by all vendors)</i>	<ul style="list-style-type: none"> Showing a liability coverage of at least \$1,000,000 Identifying "City of Jackson" & "Jackson Downtown Development Authority" as additional insured
Liquor Liability Insurance <i>(if needed)</i>	<ul style="list-style-type: none"> Identifying "City of Jackson" & "Jackson Downtown Development Authority" as additional insured
XCU Fireworks Liability Insurance <i>(if needed; required for all fireworks displays)</i>	<ul style="list-style-type: none"> Identifying "City of Jackson" & "Jackson Downtown Development Authority" as additional insured

I am a Level 1 Special Event (low resources), and would like to be considered for eligibility to enter a Hold Harmless Agreement with The City of Jackson in lieu of providing the above-required insurance documentation.

Event Map Details of all event activities MUST be included.

<input checked="" type="checkbox"/> Route Plan <input checked="" type="checkbox"/> Vendor Locations <input type="checkbox"/> Tent Locations <input type="checkbox"/> Assembly Locations	<input checked="" type="checkbox"/> Emergency Vehicle Access <input type="checkbox"/> Dispersal Locations <input type="checkbox"/> Trash Receptacles <input checked="" type="checkbox"/> Requested Street Closures	<input type="checkbox"/> Restroom Locations <input checked="" type="checkbox"/> Tables <input type="checkbox"/> Requested Reserved Parking <input type="checkbox"/> Electrical Wires & Outlets
--------------------------------------------------------------------------------------------------------------------------------------------------------------------------------------------------	-----------------------------------------------------------------------------------------------------------------------------------------------------------------------------------------------------------------------------	---------------------------------------------------------------------------------------------------------------------------------------------------------------------------------------------------------

*If these details change, a revised map must be provided seven days prior to event.
 Revised maps cannot include any additional street use, reserved parking, or additional space reservations.*

Special Event Application

Certification & Signature

1. I am the person with authority to act on behalf of the sponsoring organization.
2. I have submitted all required documents in support of the Special Event application
3. A Special Event Application Fee is submitted along with this application.
4. Only the activities listed on the application will be permitted at the event. If additional activities are added, I will immediately contact the City of Jackson. I understand that the approval of my application may be withdrawn or additional action required.
5. All food vendors must be approved by the Jackson County Health Department and each food and other vendor must provide the City of Jackson with a Certificate of Insurance which names the City of Jackson and the Downtown Development Authority as additional insured parties on the policy.
6. Fire Department permit and approval is required for events including display fireworks. Extreme Close-Up (XCU) fireworks liability insurance is required for all fireworks display.
7. The approval of this special event may include additional requirements, limitations, or fees based on the City's review of the application.
8. If I, or my organization, fail to clean up and repair damages to the event area, my organization may be billed for City services, and that failure to clean up and repair damage will be considered for future applications.
9. As the duly authorized agent of the sponsoring organization applying for approval of the Special Event, I affirm the above understandings and agree that my sponsoring organization will comply with the terms of the written confirmation of approval and all City requirements, ordinances and other laws which apply to this Special Event.
10. By signing this Special Event Application, I declare I am 21 years of age or older.
11. If required to provide liability insurance, the sponsoring organization will add the City of Jackson and the Downtown Development Authority as additional insured parties on the sponsoring organization's liability policy.
12. On behalf of the sponsoring organization, I agree that the sponsoring organization will defend, indemnify, and hold harmless the City of Jackson, its officers, employees and agents from and against any claim, demand, suit, loss, cost or expense, or any damage, which may be asserted, claimed, or recovered against or from the City of Jackson, its officers, employees, and agent, by reason of any damage to property, bodily injury, or death, sustained by any person whomsoever, and which damage, injury, or death arises out of or is incident to or in any way connected with or related to this Special Event.
13. The City of Jackson reserves the right to waive any requirements of this policy in the interests of the health, safety, and welfare of the citizens of Jackson.

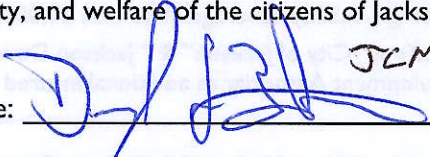
Signature: 

Date: _____

JCMC W LHAIR

Office Use ONLY
Application Received:
Date: <u>A.E.</u>
Time:
By:
Application Fee Received: <u>YES</u>

Application Requirements
Application MUST be submitted 60 days PRIOR to event ***NO EXCEPTIONS***
Application MUST be submitted along with all required attachments to: City of Jackson Downtown Development Authority Office 161 W Michigan Ave, 5 th Floor Jackson Michigan, MI 49201 or aecon@cityofjackson.org (517) 768-6411
Prohibited Items
<i>Additional fees may apply if policies are not followed</i> No ground stakes No confetti or glitter No use of outlets without prior approval



161 W. Michigan Avenue Jackson, MI 49201 – (517) 768-6411 – aecon@cityofjackson.org

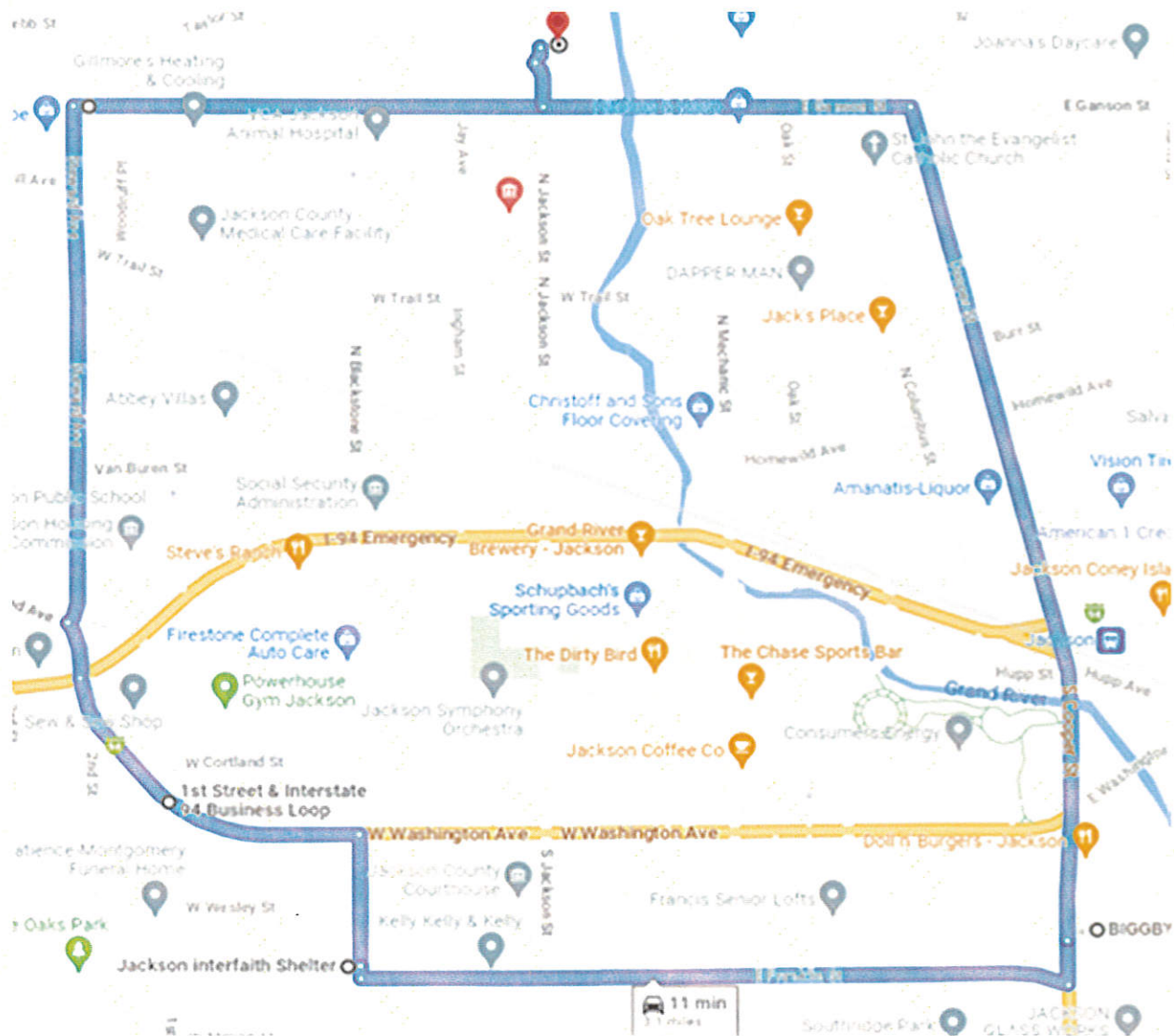

Route – Veteran Suicide Prevention Ruck March – September 9, 2023

1. Blackstone & Ganson
2. Lansing Ave & Ganson
3. Stewart & Ganson (Crossing over Ganson – Turning Left) ****Crossing Guards**
4. Stewart & Oakhill
5. Stewart & Trail (will be passing Jackson High on Right/Reed Manor on left) **CLINICIAN SPOT**
6. Stewart & Wildwood (Turning Right)
7. Wildwood & Michigan Ave/Washington (Slight Right) ****Crossing Guards**
8. Washington & 2nd St.
9. Washington & 1st St.
10. Washington & Blackstone (Turning Right) **CLINICIAN SPOT**
11. Blackstone & Wesley
12. Blackstone & Franklin (Turning Left – cross over) Interfaith Shelter on Right.
13. Vietnam Veterans of America – Chapter 109 – Stopping Point **CLINICIAN SPOT** (Water & fruit)
14. Franklin & N. Jackson
15. Franklin & Mechanic ****Site halfway mark**
16. Franklin & Martin Luther King Jr.
17. Franklin & Cooper (Go to left side of Cooper St. sidewalk)
18. Cooper & Washington
19. Cooper & Hupp ****Crossing Guards**
20. Cooper & E. Michigan Ave **** Crossing Guards**
21. Cooper & Pearl
22. Cooper & Detroit ****Site 22 CLINICIAN SPOT**
23. Cooper & Homewild
24. Cooper & Burr
25. Cooper & Trail
26. Cooper & Quarry
27. Cooper & Ganson (Cross over back to right sidewalk on Ganson)
28. Ganson & Martin Luther King Jr.
29. Ganson & Mechanic
30. Ganson & N. Jackson (Fairground entrance) **CLINICIANS ON SITE**

3.1 Miles total

Need for ruck route: * = city resource request

Safety Vests/Clinician T-shirts/Token of completion for finishing ruck – such as coin?)

Signs – route marker and halfway point – safe spots, start, finish, encourage signs

Maps/Directions of Route

Cones for Fairground Parking Lot --> *on city recourse request page

Gator or Golf Cart

8 crossing guards (2 at 4 different sites)

Vietnam Vets will man the stopping point

4 – 6 clinicians (Tables/water/Gatorade?)

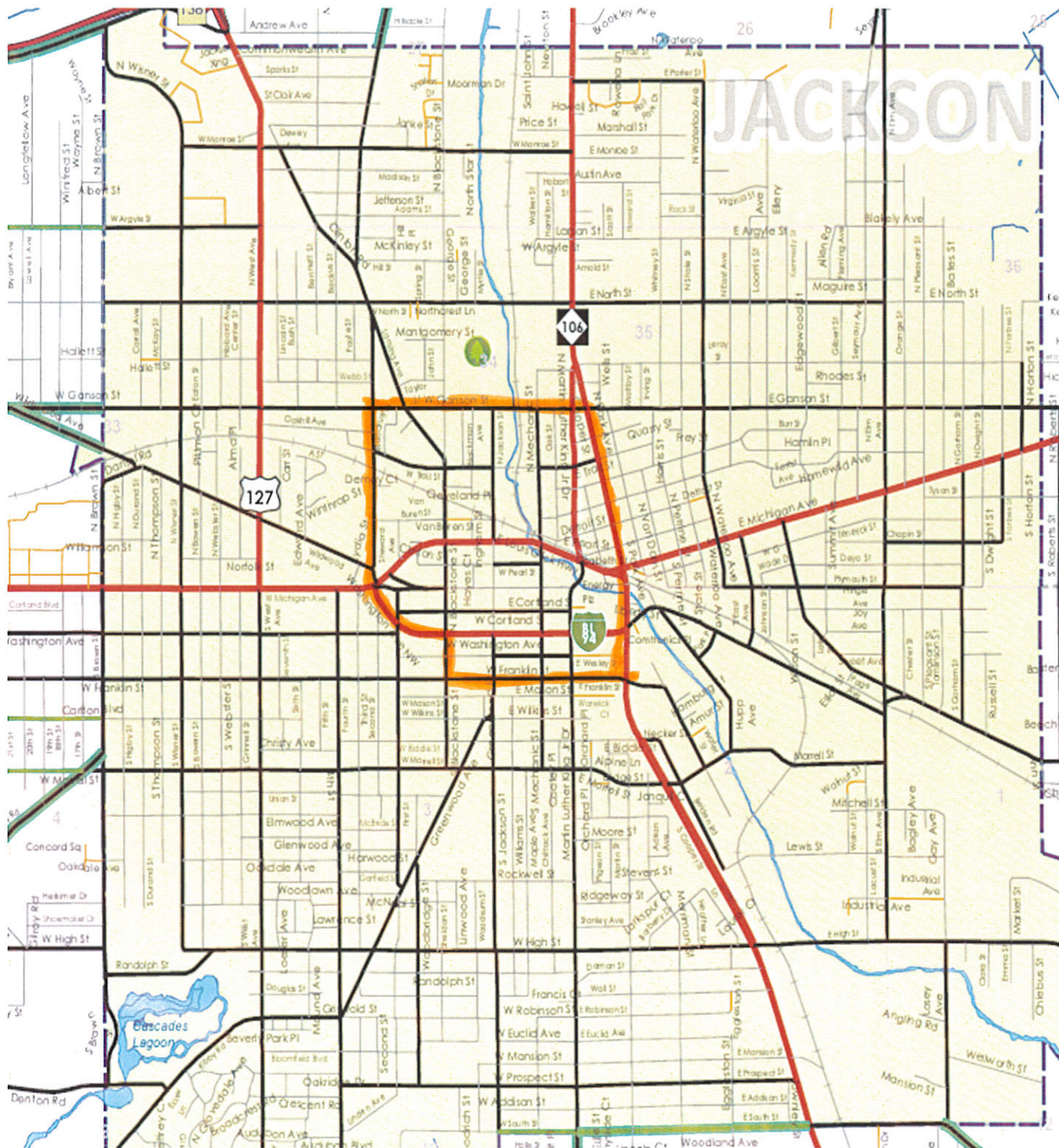

MEMO TO: Mayor and City Council Members
FROM: Jonathan Greene, City Manager
DATE: July 11, 2023
SUBJECT: Special Event Application: Home of New Vision Recovery Out Loud Walk

Recommendation:

Approve a request from the Home of New Vision to host their Recovery Out Loud Walk on September 9, 2023, on the streets/sidewalks of Jackson.

Attached is a memo and supporting paperwork from Jacqueline Austin regarding the Special Event Application for the Home of New Vision Recovery Out Loud Walk.

I recommend approval of the special event application for the Home of New Vision Recovery Out Loud Walk. Your consideration and concurrence is appreciated.

JG

DEPARTMENTAL REPORT

MEMO TO: Jonathan Greene, City Manager

FROM: Jacqueline Austin, Interim Director, DDA

DATE: July 11, 2023

RECOMMENDATION: Approve a request from the Home of New Vision to host their Recovery Out Loud Walk on September 9, 2023, on the streets/sidewalks of Jackson.

SUMMARY: Recovery walk to raise awareness regarding substance abuse recovery.

DEPARTMENTAL APPROVAL SUMMARY

Approvals noted below by each department indicate they have been made aware of the request and the capacity of their department has been met. Conditions of their approval and special considerations are noted.

<u>DEPARTMENT</u>	<u>APPROVAL</u>	<u>DENIAL</u>	<u>ECONOMIC IMPACT</u>
DDA	X		\$0.00
Engineering	X		\$0.00
Fire	X		\$0.00
Community Development	X		\$0.00
Parks & Recreation	X		\$0.00
Police	X		\$225.00
<u>Public Works</u>	X		\$0.00
	<i>TOTAL</i>		<i>\$225.00</i>

CONDITIONS & CONSIDERATIONS

Police Assistance

INSURANCE STATUS

Approved and on-file with the DDA and City Attorney

ATTACHMENTS: Special Event Application: Home of New Vision Recovery Out Loud Walk



City of Jackson Downtown Development Authority
 161 W Michigan Ave, Jackson Michigan, MI 49201
 Contact for questions at 517-768-6410 or cmays@cityofjackson.org

SPECIAL EVENT APPLICATION

Application must be submitted 60 days PRIOR to event

Application Attachments

- | | |
|-----------------------------------------------------------------------------------------|--------------------------------------------------------------------------------------|
| <input checked="" type="checkbox"/> \$50 Application Fee | <input type="checkbox"/> Liquor License & Liquor Liability Insurance (if applicable) |
| <input type="checkbox"/> \$25 Late/Rush Fee | <input type="checkbox"/> Carnival Ride Permit (if applicable) |
| <input checked="" type="checkbox"/> Insurance documentation for sponsoring organization | <input type="checkbox"/> Insurance documentation for all vendors (if applicable) |
| <input type="checkbox"/> Event Map —Please indicate the location of all items | |

Make checks payable to "Downtown Development Authority"

Special Event Application Policy

Additional charges may occur if policies are broken.

- The applicant or representative of any business, group, or organization that seeks approval to conduct a special event must be 21 years of age or older.
- No ground stakes are allowed on City property. Tents and inflatables must be weighted down.
- Glitter and confetti are prohibited at all events.
- No plugging into outlets without prior approval.
- For events utilizing street space, all fixtures (tents, vehicles, trucks, etc.) must be placed near the curbs to allow for emergency vehicle access.
- No alcoholic beverages allowed unless proper paperwork is provided along with City Council approval. Alcoholic beverages must be consumed within the area in which they are served. No containers, open or closed, may leave the event area unless approval is granted.
- Only a removable medium, such as chalk and/or tape, can be used to mark event area or routes. No paint of any kind is permitted. Tape must be removed once event is over.

Applicant Information

Sponsoring Organization Legal Name: <u>Home of New Vision</u>	
Address: <u>407 W. Michigan Ave. Jackson 49201</u>	Phone: <u>(517) 788-5596</u>
Tax ID#: <u>38-3325410</u>	Website: <u>thejarc.org</u>
Contact Name: <u>Brooke Cross</u>	Phone: <u>(517) 416-7593</u> Email: <u>bcross@homeofnewvision.org</u>
Contact Name: <u>Kathryn Williams</u>	Phone: <u>(313) 417-4969</u> Email: <u>kwilliams@homeofnewvision.org</u>
Contact Name During Event: <u>Brooke Cross</u>	Phone: ()

Event Information

Event Name: <u>Recovery Out Loud Annual Walk</u>				
Event Date(s):	Event Set up Time:	Event Start Time:	Event End Time:	Event Tear Down Time:
<u>September 9, 2023</u>	<u>9am</u>	<u>11am</u>	<u>3pm</u>	<u>3pm</u>

Has this event occurred before? Yes, (if yes, how many previous years? 7 years) No
 Do you expect this event to occur again next year? Yes What is the expected attendance for this event? 300

Type of Event (please check all that apply)

Walk/Run Festival March/Parade Other: _____

Event Location – Choose any of the following that apply. For parks, include a map of the area being used.

- Horace Blackman Park
- GrandRiver Farmers Market Pavilion
- Bucky Harris Park
- CP Federal City Square (Stage)
- Ella Sharp Park (requires Ella Sharp Board approval)
- MLK Equality Trail
- Other Location: 407 W. Michigan Ave. Jackson MI 49201
- Streets: _____
- Other Park: _____

Brief description of Event

This description will be posted on the Special Events Calendar on our website. Please attach an additional sheet if necessary.
The event will begin at HNV we will leave for the walk around Noon and return to HNV around 1pm to finish the event.
Event walk will be Michigan Ave to Mechanic to Franklin and up to Washington, returning to Home of new vision.
See attached.

Street Closure – Please indicate all street closures on your map.

Street Name: _____	Cross Streets _____
Closure Start Date: _____ Time: _____	Closure End Date: _____ Time: _____
Street Name: _____	Cross Streets _____
Closure Start Date: _____ Time: _____	Closure End Date: _____ Time: _____
Street Name: _____	Cross Streets _____
Closure Start Date: _____ Time: _____	Closure End Date: _____ Time: _____
Street Name: _____	Cross Streets _____
Closure Start Date: _____ Time: _____	Closure End Date: _____ Time: _____
Street Name: _____	Cross Streets _____
Closure Start Date: _____ Time: _____	Closure End Date: _____ Time: _____
Street Name: _____	Cross Streets _____
Closure Start Date: _____ Time: _____	Closure End Date: _____ Time: _____

City Resources Requests

Not all resources may be available at your requested site.

Please be specific and list any additional information or requests. Such requests might include assistance from the Police Department, Fire Department, Parks and Recreation Department, Public Works Department, etc. Attach additional pages, if needed.

- Electrical Power:** Indicate electrical requirements: _____
 Amount of electrical wattage needed: _____ Amount of plug ins: _____
 Locations of where plugs are needed: _____
****All electrical lines MUST be covered to limit tripping hazards. ****
- Water Needs:** Indicate water requirements: _____
 Amount of water needed: _____ Locations of where water is needed: _____
- Food/Vendors:** Indicate vendors requirements: _____
 Amount of electrical wattage needed: _____ Amount of plug ins: _____
 Locations of where plugs are needed: _____ Number of vendors: _____
- Alcohol Sales:** (If yes attach liquor license and liquor liability insurance)
 Start Time: _____ End Time: _____
- Amusement or Carnival Rides:** If yes indicate electrical requirements: _____
 Amount of electrical wattage needed: _____ Amount of plug ins: _____
 Locations of where plugs are needed: _____
- Fireworks:** If yes indicate electrical requirements: _____
 Amount of electrical wattage needed: _____ Amount of plug ins: _____
 Locations of where plugs are needed: _____
- Traffic Cones Mobile Stage (please circle 15-foot or 25-foot version)
- Other: _____

Insurance

Please request the following documentation from your insurance carrier.

Insurance Type	Requirements
Certificate of Liability Insurance <i>(MUST also be provided by all vendors)</i>	<ul style="list-style-type: none"> Showing a liability coverage of at least \$1,000,000 Identifying "City of Jackson" & "Jackson Downtown Development Authority" as additional insured
Liquor Liability Insurance <i>(if needed)</i>	<ul style="list-style-type: none"> Identifying "City of Jackson" & "Jackson Downtown Development Authority" as additional insured
XCU Fireworks Liability Insurance <i>(if needed; required for all fireworks displays)</i>	<ul style="list-style-type: none"> Identifying "City of Jackson" & "Jackson Downtown Development Authority" as additional insured

- I am a Level 1 Special Event (low resources), and would like to be considered for eligibility to enter a Hold Harmless Agreement with The City of Jackson in lieu of providing the above-required insurance documentation.

Event Map Details of all event activities MUST be included.

- | | | |
|---------------------------------------------------------------------------------------------------------------------------------------------------------------------------------------|---------------------------------------------------------------------------------------------------------------------------------------------------------------------------------------------------------------------------------------|--------------------------------------------------------------------------------------------------------------------------------------------------------------------------------------------------------------------|
| <input checked="" type="checkbox"/> Route Plan
<input type="checkbox"/> Vendor Locations
<input type="checkbox"/> Tent Locations
<input type="checkbox"/> Assembly Locations | <input type="checkbox"/> Emergency Vehicle Access
<input type="checkbox"/> Dispersal Locations
<input type="checkbox"/> Trash Receptacles
<input checked="" type="checkbox"/> Requested Street Closures <i>Police Escort</i> | <input type="checkbox"/> Restroom Locations
<input type="checkbox"/> Tables
<input checked="" type="checkbox"/> Requested Reserved Parking <i>N/A</i>
<input type="checkbox"/> Electrical Wires & Outlets |
|---------------------------------------------------------------------------------------------------------------------------------------------------------------------------------------|---------------------------------------------------------------------------------------------------------------------------------------------------------------------------------------------------------------------------------------|--------------------------------------------------------------------------------------------------------------------------------------------------------------------------------------------------------------------|

*If these details change, a revised map must be provided seven days prior to event.
 Revised maps cannot include any additional street use, reserved parking, or additional space reservations.*

Special Event Application

Certification & Signature

1. I am the person with authority to act on behalf of the sponsoring organization.
2. I have submitted all required documents in support of the Special Event application
3. A Special Event Application Fee is submitted along with this application.
4. Only the activities listed on the application will be permitted at the event. If additional activities are added, I will immediately contact the City of Jackson. I understand that the approval of my application may be withdrawn or additional action required.
5. All food vendors must be approved by the Jackson County Health Department and each food and other vendor must provide the City of Jackson with a Certificate of Insurance which names the City of Jackson and the Downtown Development Authority as additional insured parties on the policy.
6. Fire Department permit and approval is required for events including display fireworks. Extreme Close-Up (XCU) fireworks liability insurance is required for all fireworks display.
7. The approval of this special event may include additional requirements, limitations, or fees based on the City's review of the application.
8. If I, or my organization, fail to clean up and repair damages to the event area, my organization may be billed for City services, and that failure to clean up and repair damage will be considered for future applications.
9. As the duly authorized agent of the sponsoring organization applying for approval of the Special Event, I affirm the above understandings and agree that my sponsoring organization will comply with the terms of the written confirmation of approval and all City requirements, ordinances and other laws which apply to this Special Event.
10. By signing this Special Event Application, I declare I am 21 years of age or older.
11. If required to provide liability insurance, the sponsoring organization will add the City of Jackson and the Downtown Development Authority as additional insured parties on the sponsoring organization's liability policy.
12. On behalf of the sponsoring organization, I agree that the sponsoring organization will defend, indemnify, and hold harmless the City of Jackson, its officers, employees and agents from and against any claim, demand, suit, loss, cost or expense, or any damage, which may be asserted, claimed, or recovered against or from the City of Jackson, its officers, employees, and agent, by reason of any damage to property, bodily injury, or death, sustained by any person whomsoever, and which damage, injury, or death arises out of or is incident to or in any way connected with or related to this Special Event.
13. The City of Jackson reserves the right to waive any requirements of this policy in the interests of the health, safety, and welfare of the citizens of Jackson.

Signature: _____

Brooke Cross

Date: _____

1/30/2023

Office Use ONLY

Application Received:

Date: *2/1/23*

Time:

By: *And*

Application Fee Received: *yes*

Application Requirements

Application **MUST** be submitted 60 days **PRIOR** to event
*****NO EXCEPTIONS*****

Application **MUST** be submitted along with all required attachments to:

City of Jackson Downtown Development Authority
Office
161 W Michigan Ave, 5th Floor
Jackson Michigan, MI 49201 or cmays@cityofjackson.org
(517) 768-6410

Prohibited Items

Additional fees may apply if policies are not followed

No ground stakes
No confetti or glitter
No use of outlets without prior approval



161 W. Michigan Avenue Jackson, MI 49201 – (517) 768-6410 – cmays@cityofjackson.org

RECOVERY WALK ROUTE

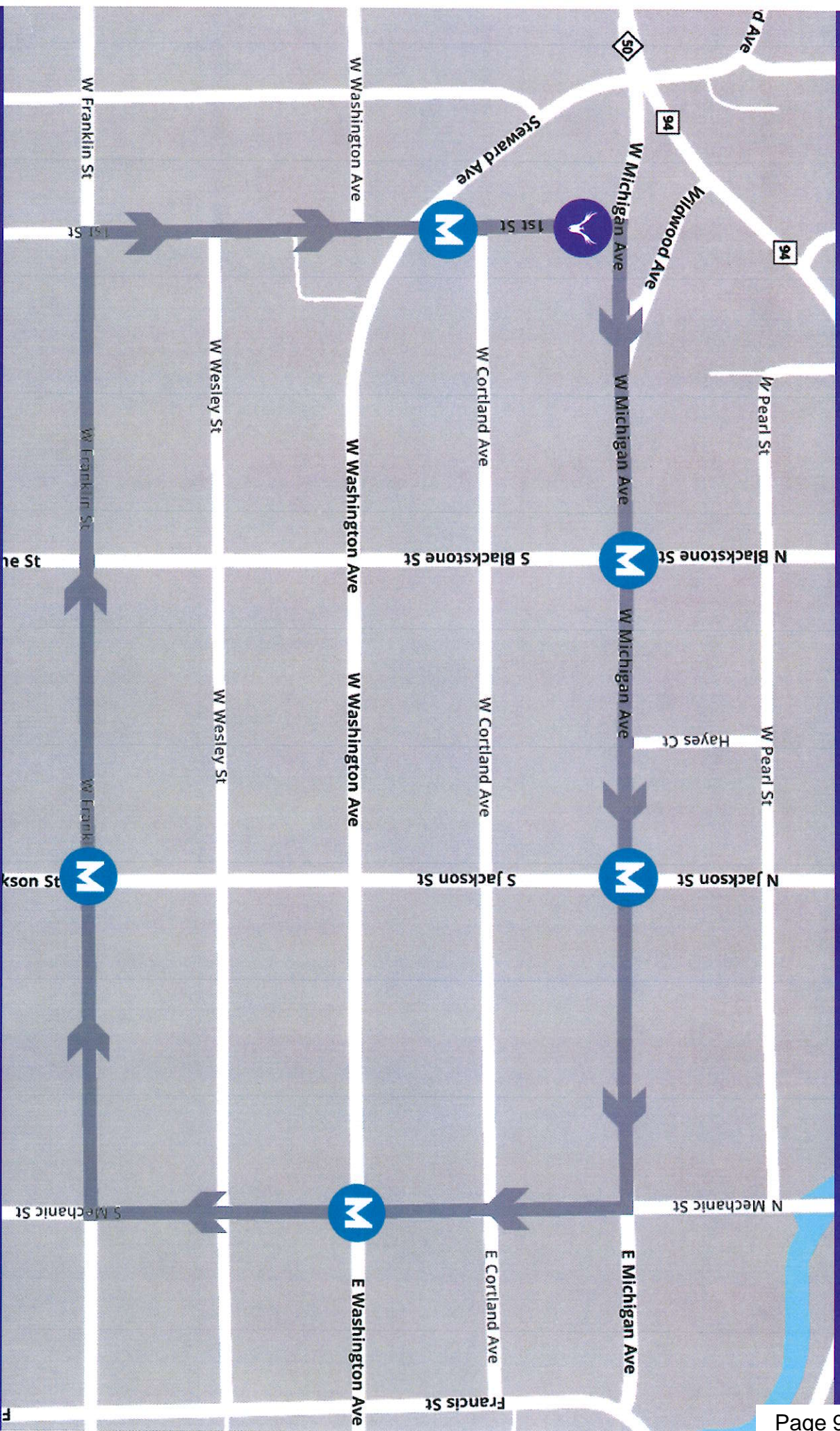

WALK START/STOP



WALK ROUTE



WALK MARSHALL

THIS ENDORSEMENT CHANGES THE POLICY. PLEASE READ IT CAREFULLY.

**ADDITIONAL INSURED – DESIGNATED
PERSON OR ORGANIZATION**

This endorsement modifies insurance provided under the following:

COMMERCIAL GENERAL LIABILITY COVERAGE PART

SCHEDULE

<p>Name Of Additional Insured Person(s) Or Organization(s): City of Jackson Jackson Downtown Development Authority</p>
<p>Information required to complete this Schedule, if not shown above, will be shown in the Declarations.</p>

A. Section II – Who Is An Insured is amended to include as an additional insured the person(s) or organization(s) shown in the Schedule, but only with respect to liability for "bodily injury", "property damage" or "personal and advertising injury" caused, in whole or in part, by your acts or omissions or the acts or omissions of those acting on your behalf:

1. In the performance of your ongoing operations; or
2. In connection with your premises owned by or rented to you.

However:

1. The insurance afforded to such additional insured only applies to the extent permitted by law; and
2. If coverage provided to the additional insured is required by a contract or agreement, the insurance afforded to such additional insured will not be broader than that which you are required by the contract or agreement to provide for such additional insured.

B. With respect to the insurance afforded to these additional insureds, the following is added to **Section III – Limits Of Insurance:**

If coverage provided to the additional insured is required by a contract or agreement, the most we will pay on behalf of the additional insured is the amount of insurance:

1. Required by the contract or agreement; or
2. Available under the applicable Limits of Insurance shown in the Declarations;

whichever is less.

This endorsement shall not increase the applicable Limits of Insurance shown in the Declarations.

MEMO TO: Mayor and City Council Members
FROM: Jonathan Greene, City Manager
DATE: July 11, 2023
SUBJECT: Special Event Application: Downtown Day

Recommendation:

Approve a request from the Jackson Downtown Development Authority to host Downtown Day on July 30, 2023 in Horace Blackman Park, Bucky Harris Park, and various downtown sidewalks/parking lots.

Attached is a memo and supporting paperwork from Jacqueline Austin regarding the Special Event Application for Downtown Day.

I recommend approval of the Downtown Day event. Your consideration and concurrence is appreciated.

JG

DEPARTMENTAL REPORT

MEMO TO: Jonathan Greene, City Manager

FROM: Jacqueline Austin, Interim Director, DDA

DATE: July 11, 2023

RECOMMENDATION: Approve a request from the Jackson Downtown Development Authority to host their Downtown Day on Sunday, July 30, 2023 from 11 am – 4 pm in downtown Jackson.

SUMMARY: Retail event featuring food trucks, sidewalk sales, craft vendors, music, bubbles, and shopping fun.

DEPARTMENTAL APPROVAL SUMMARY

Approvals noted below by each department indicate they have been made aware of the request and the capacity of their department has been met. Conditions of their approval and special considerations are noted.

<u>DEPARTMENT</u>	<u>APPROVAL</u>	<u>DENIAL</u>	<u>ECONOMIC IMPACT</u>
DDA	X		\$0.00
Engineering	X		\$0.00
Fire	X		\$0.00
Community Development	X		\$0.00
Parks & Recreation	X		\$0.00
Police	X		\$0.00
Public Works	X		\$0.00
	<i>TOTAL</i>		<i>\$0.00</i>

CONDITIONS & CONSIDERATIONS

Additional garbage cans & picnic tables; no-parking tripods, electrical for food trucks

INSURANCE STATUS

This event is covered under the City of Jackson's insurance policy.

ATTACHMENTS: Special Event Application: Downtown Day

SPECIAL EVENT APPLICATION

Application must be submitted 60 days PRIOR to event

Application Attachments

- | | |
|------------------------------------------------------------------------------------------|--------------------------------------------------------------------------------------|
| <input type="checkbox"/> \$50 Application Fee | <input type="checkbox"/> Liquor License & Liquor Liability Insurance (if applicable) |
| <input type="checkbox"/> \$25 Late/Rush Fee | <input type="checkbox"/> Carnival Ride Permit (if applicable) |
| <input type="checkbox"/> Insurance documentation for sponsoring organization | <input type="checkbox"/> Insurance documentation for all vendors (if applicable) |
| <input checked="" type="checkbox"/> Event Map —Please indicate the location of all items | |

Make checks payable to “Downtown Development Authority”

Special Event Application Policy

Additional charges may occur if policies are broken.

- The applicant or representative of any business, group, or organization that seeks approval to conduct a special event must be 21 years of age or older.
- No ground stakes are allowed on City property. Tents and inflatables must be weighted down.
- Glitter and confetti are prohibited at all events.
- No plugging into outlets without prior approval.
- For events utilizing street space, all fixtures (tents, vehicles, trucks, etc.) must be placed near the curbs to allow for emergency vehicle access.
- No alcoholic beverages allowed unless proper paperwork is provided along with City Council approval. Alcoholic beverages must be consumed within the area in which they are served. No containers, open or closed, may leave the event area unless approval is granted.
- Only a removable medium, such as chalk and/or tape, can be used to mark event area or routes. No paint of any kind is permitted. Tape must be removed once event is over.

Applicant Information

Sponsoring Organization Legal Name: Jackson Downtown Development Authority	
Address: 161 W. Michigan Avenue Jackson, MI 49201	Phone: (517) 768-6410
Tax ID#:	Website: www.jacksondda.org
Contact Name: Andrea Econ	Phone: 517-768-6411 Email: aecon@cityofjackson.org
Contact Name:	Phone: Email:
Contact Name During Event: SAME	Phone: (517) 392-7912

Event Information

Event Name: Downtown Day				
Event Date(s):	Event Set up Time:	Event Start Time:	Event End Time:	Event Tear Down Time:
Sunday, July 30	9 am	11 am	4 pm	5 pm

Has this event occurred before? Yes, (if yes, how many previous years? 2) No

Do you expect this event to occur again next year? YES What is the expected attendance for this event? 400-500

Type of Event (please check all that apply)

Walk/Run Festival March/Parade Other: _____

Event Location – Choose any of the following that apply. For parks, include a map of the area being used.

Horace Blackman Park GrandRiver Farmers Market Pavilion

Bucky Harris Park CP Federal City Square (Stage)

Ella Sharp Park (requires Ella Sharp Board approval) MLK Equality Trail

Other Location: Downtown Sidewalks ; parking lot #8 (post office only-some parking spaces)

Streets: Michigan Ave, Jackson, Mechanic (angled parking spaces only)

Other Park: _____

Brief description of Event

This description will be posted on the Special Events Calendar on our website. Please attach an additional sheet if necessary.

A downtown shopping and family-friendly event featuring food trucks, pop-up vendors, live music, and bubbles.

Street Closure– Please indicate all street closures on your map.

Street Name: _____ Cross Streets _____

Closure Start Date: _____ Time: _____ Closure End Date: _____ Time: _____

Street Name: _____ Cross Streets _____

Closure Start Date: _____ Time: _____ Closure End Date: _____ Time: _____

Street Name: _____ Cross Streets _____

Closure Start Date: _____ Time: _____ Closure End Date: _____ Time: _____

Street Name: _____ Cross Streets _____

Closure Start Date: _____ Time: _____ Closure End Date: _____ Time: _____

Street Name: _____ Cross Streets _____

Closure Start Date: _____ Time: _____ Closure End Date: _____ Time: _____

Street Name: _____ Cross Streets _____

Closure Start Date: _____ Time: _____ Closure End Date: _____ Time: _____

City Resources Requests

Not all resources may be available at your requested site.

Please be specific and list any additional information or requests. Such requests might include assistance from the Police Department, Fire Department, Parks and Recreation Department, Public Works Department, etc. Attach additional pages, if needed.

Electrical Power: Indicate electrical requirements: Outlets on the side of Lean Rocket Lab + Parks
 Amount of electrical wattage needed: _____ Amount of plug ins: _____
 Locations of where plugs are needed: _____
****All electrical lines MUST be covered to limit tripping hazards. ****

Water Needs: Indicate water requirements: _____
 Amount of water needed: _____ Locations of where water is needed: _____

Food/Vendors: Indicate vendors requirements: Health Dept. License, from the DDA-approved list
 Amount of electrical wattage needed: _____ Amount of plug ins: _____
 Locations of where plugs are needed: _____ Number of vendors: _____

Alcohol Sales: (If yes attach liquor license and liquor liability insurance)
 Start Time: _____ End Time: _____

Amusement or Carnival Rides: If yes indicate electrical requirements: _____
 Amount of electrical wattage needed: _____ Amount of plug ins: _____
 Locations of where plugs are needed: _____

Fireworks: If yes indicate electrical requirements: _____
 Amount of electrical wattage needed: _____ Amount of plug ins: _____
 Locations of where plugs are needed: _____

Traffic Cones Mobile Stage (please circle **15-foot** or **25-foot** version)

Other: 6 trash cans (1 each at of the 6 food truck stations);
6 picnic tables (1 at each of the 6 food truck stations); restrooms will be placed in Bucky Harris Park (2)

Insurance

Please request the following documentation from your insurance carrier.

Insurance Type	Requirements
Certificate of Liability Insurance <i>(MUST also be provided by all vendors)</i>	<ul style="list-style-type: none"> Showing a liability coverage of at least \$1,000,000 Identifying "City of Jackson" & "Jackson Downtown Development Authority as additional insured
Liquor Liability Insurance <i>(if needed)</i>	<ul style="list-style-type: none"> Identifying "City of Jackson" & "Jackson Downtown Development Authority" as additional insured
XCU Fireworks Liability Insurance <i>(if needed; required for all fireworks displays)</i>	<ul style="list-style-type: none"> Identifying "City of Jackson" & "Jackson Downtown Development Authority" as additional insured

I am a Level I Special Event (low resources), and would like to be considered for eligibility to enter a Hold Harmless Agreement with The City of Jackson in lieu of providing the above-required insurance documentation.

Event Map *Details of all event activities MUST be included.*

<input checked="" type="checkbox"/> Route Plan	<input type="checkbox"/> Emergency Vehicle Access	<input checked="" type="checkbox"/> Restroom Locations
<input checked="" type="checkbox"/> Vendor Locations	<input type="checkbox"/> Dispersal Locations	<input checked="" type="checkbox"/> Tables
<input type="checkbox"/> Tent Locations	<input checked="" type="checkbox"/> Trash Receptacles	<input type="checkbox"/> Requested Reserved Parking
<input type="checkbox"/> Assembly Locations	<input type="checkbox"/> Requested Street Closures	<input type="checkbox"/> Electrical Wires & Outlets

*If these details change, a revised map must be provided seven days prior to event.
 Revised maps cannot include any additional street use, reserved parking, or additional space reservations.*

Special Event Application

Certification & Signature

1. I am the person with authority to act on behalf of the sponsoring organization.
2. I have submitted all required documents in support of the Special Event application
3. A Special Event Application Fee is submitted along with this application.
4. Only the activities listed on the application will be permitted at the event. If additional activities are added, I will immediately contact the City of Jackson. I understand that the approval of my application may be withdrawn or additional action required.
5. All food vendors must be approved by the Jackson County Health Department and each food and other vendor must provide the City of Jackson with a Certificate of Insurance which names the City of Jackson and the Downtown Development Authority as additional insured parties on the policy.
6. Fire Department permit and approval is required for events including display fireworks. Extreme Close-Up (XCU) fireworks liability insurance is required for all fireworks display.
7. The approval of this special event may include additional requirements, limitations, or fees based on the City's review of the application.
8. If I, or my organization, fail to clean up and repair damages to the event area, my organization may be billed for City services, and that failure to clean up and repair damage will be considered for future applications.
9. As the duly authorized agent of the sponsoring organization applying for approval of the Special Event, I affirm the above understandings and agree that my sponsoring organization will comply with the terms of the written confirmation of approval and all City requirements, ordinances and other laws which apply to this Special Event.
10. By signing this Special Event Application, I declare I am 21 years of age or older.
11. If required to provide liability insurance, the sponsoring organization will add the City of Jackson and the Downtown Development Authority as additional insured parties on the sponsoring organization's liability policy.
12. On behalf of the sponsoring organization, I agree that the sponsoring organization will defend, indemnify, and hold harmless the City of Jackson, its officers, employees and agents from and against any claim, demand, suit, loss, cost or expense, or any damage, which may be asserted, claimed, or recovered against or from the City of Jackson, its officers, employees, and agent, by reason of any damage to property, bodily injury, or death, sustained by any person whomsoever, and which damage, injury, or death arises out of or is incident to or in any way connected with or related to this Special Event.
13. The City of Jackson reserves the right to waive any requirements of this policy in the interests of the health, safety, and welfare of the citizens of Jackson.

Signature: Andrea D Econ

Date: 6/5/23

Office Use ONLY
Application Received:
Date:
Time: N/A
By:
Application Fee Received:

Application Requirements
Application MUST be submitted 60 days PRIOR to event ***NO EXCEPTIONS***
Application MUST be submitted along with all required attachments to: City of Jackson Downtown Development Authority Office 161 W Michigan Ave, 5 th Floor Jackson Michigan, MI 49201 or cmays@cityofjackson.org (517) 768-6410
Prohibited Items
<i>Additional fees may apply if policies are not followed</i>
No ground stakes No confetti or glitter No use of outlets without prior approval

Food trucks will park in angled parking spaces only, and no roads will be closed. Please place 1 trash can and 1 picnic table near each food truck location. Thanks!

BLACKSTONE ST.

Public Parking

Food Truck

LOUIS GLICK HWY.

PEARL ST.

Food Truck

Rest Rooms

Bubble Fun

Vendors

Food Truck

MECHANIC ST.

WEST MICHIGAN AVE.

Food Truck

Food Truck

CORTLAND ST.

Food Truck

MEMO TO: Jonathan Greene, City Manager
FROM: Michael Osborn, Director of Public Works
DATE: July 11, 2023
SUBJECT: **Public Works Forestry Services contract extension with Johnny's Tree Service, Inc.**

Recommendation:

Approval of the one-year contract extension with Johnny's Tree Service, Inc., for as-needed tree trimming, tree removals, and stump grinding, with a 2.5% increase for an estimated cost of \$206,800 for the fiscal year 2023/24.

Attached is a report from Michael Osborn, Director of Public Works regarding the contract extension referenced above.

Your consideration and concurrence is appreciated.

DEPARTMENTAL REPORT

MEMO TO: Jonathan Greene, City Manager
FROM: Michael Osborn, Director of Public Works
DATE: July 11, 2023

RECOMMENDATION: Approval of a one-year contract extension with Johnny’s Tree Service, Inc., for as-needed tree trimming, tree removals, and stump grinding, with a 2.5% increase for an estimated cost of \$206,800 for the fiscal year 2023/24.

SUMMARY

The City of Jackson maintains an ever-changing list of forestry services that include tree trimming, tree removal, and stump grinding in the public right-of-ways and on other city-owned public property. The City requested bids for these as-needed forestry services in 2022 with Johnny’s Tree Service, Inc. being the lowest responsible bidder therefore they were awarded the contract. Before the 2022 contract award, Johnny’s Tree Service, Inc. had held the contract for the previous two years at the same rates as their original bid in 2019. This one-year contract extension would be the first of two one-year renewals available per the current contract.

BUDGETARY CONSIDERATIONS

Funding for these services is budgeted in the Department of Public Works, Forestry Contractual budget line 101-442-000-818.000. The budgeted amount for the fiscal year 2023/24 is approximately \$206,800.

HISTORY, BACKGROUND and DISCUSSION

The City’s forestry services typically include maintaining the trees located along public right-of-ways, City parks, and on other City owned public property. This contract allows for maintenance trimming and removals, and grinding of the tree stumps that remain following tree removals. This contract also allows Johnny’s Tree Service, Inc. to provide these same services after a storm event when they are especially needed to keep the City streets safe and clear of debris. In providing a faster response to better service to the residents of the City of Jackson, the contractor’s services are used to augment the services provided by city staff.

Johnny’s Tree Service, Inc. has done an exceptional job as the City’s contractor providing these services over the past several years. Both the City and the contractor would like to extend the contract for another year with the 2.5% increase as stated in the contract. If we were not to approve this extension of the contract this year the fear is that the cost to provide these services would be considerably more, due to the rise in the current inflation rate over the past year. In an effort to save money and maintain the same level of services, we believe it would be in the City’s best interest to approve this extension.

DISCUSSION ON THE ISSUE

This work is vital to maintaining the urban forestry contained within the city limits along public right-of-ways and on other city-owned public property. The ability to utilize this contractor will aid in improving our response time and decrease the number of forestry projects that await necessary attention.

POSITIONS

I recommend approval of the one-year contract extension with Johnny’s Tree Service, Inc. for as-needed tree trimming, tree removals, and stump grinding services for the 2023/24 fiscal year.

JOHNNY'S TREE SERVICE INC.

1245 FALAHEE ROAD
JACKSON, MICHIGAN
P.O. BOX 345
MICHIGAN CENTER, MI 49254
(517) 764-2444

We at Johnny's Tree Service accept the renewal of the contract from September 1st 2023 to August 31st 2024 at the 2.5% rate increase. If you have any questions please let us know.

Cameron Smith

Owner

MEMO TO: Mayor and City Councilmembers
FROM: Jonathan Greene, City Manager
DATE: July 11, 2023
SUBJECT: Purchase of 4,000 tons of road salt for the 2023/2024 winter season

Recommendation:

Approve the purchase of 4,000 tons of road salt from Detroit Salt Company at a cost of \$77.87 per ton for a total amount of \$311,480, for the 2023/2024 winter season through cooperative bidding with the Jackson County Department of Transportation.

These purchases are budgeted in 202-478-000-782.000 and 203-478-000-782.000, Major and Local Street Winter Maintenance.

Your consideration and concurrence is appreciated.

JG

DEPARTMENTAL REPORT

MEMO TO: Jonathan Greene, City Manager

FROM: Michael Osborn, Director of Public Works

DATE: July 11, 2023

RECOMMENDATION: Approval of the purchase of 4,000 tons of road salt from Detroit Salt Company for \$77.87 per ton for a total of \$311,480.00 for the 2023/2024 winter season.

SUMMARY

The Jackson County Department of Transportation graciously allows the City to cooperatively purchase road salt through their annual competitive bidding process, and the results of the season bid is to Detroit Salt Company with a cost of \$77.87 per ton. The cost for last year's winter season road salt was \$75.32 per ton. The 2023/2024 road salt cost per ton would be an approximate increase of 3.3% over last year's cost per ton.

BUDGETARY CONSIDERATIONS

The City uses approximately 4,000 tons of road salt per year, and given the bid of \$77.87 per ton, the total cost for the 2023/2024 winter season is \$311,480.00. These purchases are budgeted in the 202-478-000-782.000 and 203-478-000-782.000, Major and Local Street Winter Maintenance.

HISTORY, BACKGROUND and DISCUSSION

These quantities and purchase amounts remain consistent with previous years, and our expectations for required use remain the same for the upcoming 2023/2024 winter season. By spreading salt on our roads we are able to keep them safe and reasonably free from ice in the winter months. Without the salt we would not be able to manage ice buildup on the roads.

POSITIONS

I recommend approval of the road salt purchase from Detroit Salt Company in the amount of \$311,480.00 through the cooperative bid with the Jackson County Department of Transportation.

ATTACHMENTS

BID TAB: RFB#110J-23-SODIUM CHLORIDE

DELIVERY SITE	VENDOR	VENDOR	VENDOR
	CARGILL INC.	COMPASS MINERALS	DETROIT SALT
MARSHALL	\$85.95	\$89.95	\$80.71
BATTLE CREEK	\$85.95	\$89.95	\$80.71
ALBION	\$85.95	\$89.95	\$80.71
CLARK LAKE	\$85.95	\$86.17	\$77.87
JACKSON	\$85.95	\$86.17	\$77.87
HENRIETTA	\$85.95	\$86.17	\$77.87
PARMA	\$85.95	\$86.17	\$77.87
CITY OF JACKSON	\$85.95	\$86.17	\$77.87
PICK UP	\$85.00	\$83.00	\$77.00

**ATTACHMENT C
 BID SHEET RFP#110J-23**

<u>DELIVERY LOCATION</u>	<u>*EST. TONS/YEAR</u>	<u>PRICE/TON</u>
Marshall Garage 13300 15 Mile Rd. Marshall, MI 49068	*7,500 +/-	\$ <u>80.71/ton</u>
Battle Creek Garage 1040 S. Raymond Rd. Battle Creek, MI 49014	*6,500 +/-	\$ <u>80.71/ton</u>
Albion Garage 12980 27 Mile Rd. Albion, MI 49224	*3,000 +/-	\$ <u>80.71/ton</u>
Clark Lake Garage 7245 Clark Lake Road Clark Lake, MI 49234	*8,000 +/-	\$ <u>77.87/ton</u>
Jackson Garage 2400 N. Elm Road Jackson, MI 49201	*6,000 +/-	\$ <u>77.87/ton</u>
Henrietta Garage 11750 Bunkerhill Rd. Pleasant Lake, MI 49272	*6,000 +/-	\$ <u>77.87/ton</u>
Parma Garage 2491 N. Parma Road Parma MI, 49269	*8,000 +/-	\$ <u>77.87/ton</u>
City of Jackson 161 W. Michigan Ave. Jackson, MI 49201	*4,000 +/-	\$ <u>77.87/ton</u>

Stockpile locations: Detroit, MI

Requested Terms of Payment: Net 30

ALTERNATE BID: Salt to be picked up by the Road Department at stockpile location and loaded by supplier.

Loaded by bidder per ton: \$ 77.00

(Attachment C – continued)

COMPLETE FOR BID SHEET C

Company or Bidder's Name: Detroit Salt Company, L.C.

Address: 12841 Sanders St.

City: Detroit **State:** MI **Zip:** 48217

Telephone Number: 313-841-5144 **Fax Number:** 313-841-1102

Contact Person: Jean Szatkowski

Title: Senior Bid Analyst

Email Address: sales@detroitsalt.com

Authorized Signature: 
Richelle Labut, Business Operations Manager

Date: 02/24/2023

EXCEPTIONS/NOTES: see attached

Quantities shown within this contract shall not be construed to represent any amount which the County shall be obligated to purchase under this contract, or relieve the contractor of his obligation to fill all orders placed by the County.

**INCOMPLETE BID RESPONSES MAY BE DEEMED AS NON-RESPONSIVE AND
ELIMINATED FROM FURTHER CONSIDERATION BY THE COUNTY,
Ref. Section 3.3 "Contents of Proposal".**

*** Estimated quantities only and subject to change due to weather.**

MEMO TO: Mayor and City Councilmembers
FROM: Jonathan Greene, City Manager
DATE: July 11, 2023
SUBJECT: Award the Loomis Park Playground Project Change Order 2 to R.W. Mercer of Jackson, Michigan in the lesser amount of -\$8,005.00

Recommendation:

Award the Loomis Park Playground Project Change Order 2 to R.W. Mercer of Jackson, Michigan in the lesser amount of -\$8,005.00

Attached is a memo from Kelli Hoover, Director of Parks, Recreation and Cemeteries regarding the Loomis Park Playground project.

We recommend approval of the contract to R.W. Mercer of Jackson, Michigan and authorization for the Mayor and City Clerk to execute the appropriate documents. Your consideration and concurrence is appreciated.

JG

DEPARTMENTAL REPORT

MEMO TO: Jonathan Greene, City Manager

FROM: Kelli Hoover, Director Parks, Recreation and Cemeteries

DATE: July 13, 2023

RECOMMENDATION: Award the Loomis Park Playground Project Phase 2 Change Order 2 to R. W. Mercer of Jackson, Michigan in the lesser amount of -\$8,005.00

SUMMARY

Award the Loomis Park Playground Project Phase 2 Change Order 2 to R.W. Mercer of Jackson, Michigan in the lesser amount of -\$8,005.00

BUDGETARY CONSIDERATIONS

The change order represents a decreased amount of \$8005.00 bringing the current contract amount to \$1,322,675.00.

HISTORY, BACKGROUND and DISCUSSION

On November 22, 2022, City Council approved the award of the contract to R.W. Mercer of Jackson, Michigan in the amount of \$1,330,680.00.

DISCUSSION OF THE ISSUE

The project was able to move forward without handrails on the walking path due to the addition of the path from the playground connecting to the basketball court trails and reworking the surface area.

POSITIONS

I request approval of balancing the Change Order No.2 and authorization for the City Manager and Director of Parks and Recreation to sign the document.



2322 Brooklyn Rd.
 Jackson, MI 49203
 Ph : (517) 787-2960

TRUST. PERFORMANCE. PRIDE.

Change Order

Project:
 22.0321.04 Boos Recreation Center
 210 Gilbert St.
 Jackson, MI 49201

Change Order: 2
Date: 6/7/2023
Architect's Project:

To Owner:

The Contract is changed as follows:

3	CHANGE ORDER #3	\$-8,005.00
	DEDUCT (\$10,855) FOR NO HANDRAILING REQUIRED	
	REMOVAL OF ADDITIONAL TREE \$2,850.00	
	TOTAL: \$8,005.00	

The original Contract Amount was	\$1,305,090.00
Net change by previously authorized Change Orders	\$25,590.00
The Contract Amount prior to this Change Order was	\$1,330,680.00
The Contract will be increased by this Change Order in the amount of	\$-8,005.00
The new Contract Amount including this Change Order will be	\$1,322,675.00

The date of Substantial Completion as of the date of this Change Order therefore is

NOT VALID UNTIL SIGNED BY THE ARCHITECT, CONTRACT AND OWNER.

ARCHITECT	RW Mercer Co CONTRACTOR 2322 Brooklyn Rd. Jackson, MI 49203	OWNER
-----------	----------------------------------------------------------------------	-------

(Signature)	(Signature)	(Signature)
By	By	By
Date	Date	Date

MEMO TO: Mayor and Councilmembers
FROM: Jonathan Greene, City Manager
DATE: July 11, 2023
SUBJECT: **Professional Engineering Services Contract with Fishbeck, for Construction Administration Services for the Drinking Water State Revolving Fund**

Recommendation:

Approval of Professional Engineering Services Contract with Fishbeck, for Construction Administration of the Fiscal Year 2023 Drinking Water State Revolving Fund Improvement projects at a not to exceed amount of \$134,000.

Your consideration is appreciated.

DEPARTMENTAL REPORT

MEMO TO: Jonathan Greene, City Manager
FROM: Michael Osborn, Director of Public Works
DATE: July 11, 2023

RECOMMENDATION: Approval of Professional Engineering Services Contract with Fishbeck, for Construction Administration of the Fiscal Year 2023 Drinking Water State Revolving Fund (DWSRF) Improvement projects at a not to exceed amount of \$134,000.

SUMMARY

Fishbeck will oversee the DWSRF project's progress, ensuring all jobs are completed according to the plans and contract documents. They will also respond to issues that may arise during the construction phase of this project, including requests for information from the contractors, and providing clarification and interpretation of the City's and DWSRF's contract documents. Fishbeck will visit the project sites regularly and provide final punch list inspections to ensure the project is completed per approved specifications. Fishbeck will also review the contractor's weekly payroll reports to ensure compliance with Davis Bacon's prevailing wage requirements, which are mandated by the funding agency.

BUDGETARY CONSIDERATIONS

The funding for the Fishbeck Professional Engineering Services – Construction Administration for the DWSRF project will be paid for through the American Rescue Plan grant, the Bipartisan Infrastructure Bill grant, or through the DWSRF loan in the not to exceed amount of \$134,000.

HISTORY, BACKGROUND and DISCUSSION

On June 14, 2022, the City adopted the resolution for the water system improvements final project plan as part of the city's DWSRF loan application, with approximately \$12.4 million in loan principal forgiveness, American Rescue Plan, and Bipartisan Infrastructure Law grants. With the tentative contract awards approved by City Council on May 23, 2023, we will then move into the construction phase of the DWSRF projects upon the loan closing in mid-July. Professional engineering construction administration services are essential in ensuring a project of this magnitude is executed per the contract and specifications. If City Council were to vote no, there would be no professional engineering construction administration services for this multi-million dollar project. Additionally, Fishbeck will bring their much-needed engineering expertise and experience to the project, as they were the engineering consultant that developed the project plans for the water system improvements.

The projects Fishbeck will provide the engineering construction administration are, lime and soda ash system improvements, cast iron floor drains and piping, return flow metering, new starters for the well pump motors, new mixers for the elevated tanks, and Davis-Bacon prevailing wage payroll review and field interviews for the contractors associated with the lead service line replacements.

POSITIONS

Approval of Professional Engineering Services Contract with Fishbeck, for Construction Administrative Services for the Drinking Water State Revolving Fund (DWSRF) not to exceed \$134,000.

June 13, 2023

Mike Osborn
Director of Public Works
City of Jackson
161 West Michigan Avenue, 11th Floor
Jackson, Michigan 49201

**Proposal for Professional Engineering Services
DWSRF FY 2023 Improvements – Construction Administration Services**

Fishbeck is pleased to submit this proposal for construction administration services related to the Drinking Water State Revolving Fund (DWSRF) Fiscal Year (FY) 2023 Improvements project. Fishbeck is designing the DWSRF FY 23 Improvements projects as presented in the *DWSRF Project Plan* submitted for the City of Jackson (City) in 2022. The projects proposed in the project plan have been listed within the *Intended Use Plan (IUP)* published by Michigan Department of Environment, Great Lakes, and Energy (EGLE) for the FY 2023 funding cycle. The City is receiving a total of \$8,437,255 in ARP grant funds for these projects. The Lead Service Line Replacement (LSLR) project is being funded through \$887,255 in ARP grant funds, and \$8,112,745 in Bipartisan Infrastructure Law (BIL) DWSRF Loan and Principal Forgiveness for the LSLR.

The water main design was not completed by Fishbeck, and the City is self-performing the LSLR replacements. Therefore, construction administration services for the water main projects are not included in this proposal. However, the City would like Fishbeck to provide the Davis-Bacon payroll review and field interviews for the contractors associated with the LSLR Replacement.

We understand the City is seeking construction administration services related to the DWSRF FY 23 Improvements project. The project bid in March 2023 in accordance with a Quarter 3.5 DWSRF funding schedule. Construction would be expected to begin in Spring of 2023 (dependent on the availability of construction materials).

Background

The project needs for the proposed water treatment plant (WTP) improvements, well pump motors and elevated storage tanks, were identified as a part of the *DWSRF Project Plan* submitted to EGLE in 2022. The following improvements were recommended:

1. Installation of mixers at the East and West Elevated Storage Tanks.
2. Replacement of well pump motor starters with soft starters at all 16 source water wells.
3. Improvements at the WTP:
 - a. Replacement of the lime and soda ash fill lines, including installation of safety railings.
 - b. Replacement of old cast iron floor drains associated piping, and separation of sewer lines from the floor drains.
 - c. Installation of a flow meter on the existing return flow stream.

Project Understanding

Water Treatment Plant

Lime and Soda Ash System

The WTP uses lime and soda ash for the water softening process. These chemicals are stored in three bins on top of the WTP roof. Each bin has its own dedicated fill line, with three long radius bends and supports. The fill lines and supports are original to the plant and need to be replaced. As part of the project, permanent railing will be installed around the perimeter of the roof area to provide a safe workspace during construction. Therefore, the following scope of improvements is included:

- Removal and replacement of the lime and soda ash feed lines, long radius bends, and associated supports with new 4-inch carbon steel piping.
- Installation of a permanent railing around the perimeter of the roof as a safety measure for maintenance work in this area.

Cast Iron Floor Drains and Piping

There are several 4-inch cast iron floor drains in the basement of the WTP that are original to the plant. These drains are beyond their useful life, performing poorly, clogged with debris and pipe tuberculation. In addition, the sanitary waste piping from the locker rooms, and bathrooms on the floor above is connected to the same drain piping as the basement floor drains and leads to a common sump. When the drains become clogged, sanitary waste comes up through the floor drains, and floods the WTP basement. In addition to the health concerns caused by this flooding, the critical electrical and mechanical equipment located on and near the basement floor must stay dry.

Therefore, the following scope of improvements is included:

- Removal and replacement of existing cast iron floor drains, along with the associated drain piping. This includes concrete floor slab removal, and replacement of approximately two feet to either side of the existing drains and pipe.
- Disconnection of the existing combined locker room sanitary line from the floor drains. Installation of separate piping for the upstairs locker room, and restroom sanitary waste lines.

Return Flow Metering

The WTP operates as a surface water softening and treatment plant because it returns backwash and lime sludge lagoon decanted water for additional treatment. Under current State of Michigan and EGLE rules, the WTP can only supply 10% of the total treated plant flow from the return flow stream. Currently, the WTP operators estimate the volume of the return flow, based on pump capacities, and run time, but there is no flow meter installed on the return flow line to record measurements. An electromagnetic meter installed on the line would allow the return flow to be monitored and logged.

Therefore, the following scope of improvements is included:

- Installation of a magnetic flow meter on the return flow line.

Well Pump Motors

The motors for all 16 water supply wells do not have soft starts. This leads to wear and tear on the motors and associated equipment due to the inrush current and torque for a temporary period. There is also the potential for hydraulic transients associated with the sudden startup which can lead to pressure surges and breaks in the raw water main. The addition of soft starts to the existing well pump motors would mitigate these issues.

Therefore, the following scope of improvements is included:

- Installation of soft starts on all existing supply wells.

Elevated Storage Tanks

The East and West Elevated Storage Tanks are critical components in the distribution system. Historic water demands in the City's water system have declined in recent years, as some large industrial users have left. This reduced demand has decreased the rate of turnover in the elevated tanks, resulting in issues with thermal stratification, which can lead to microbial growth, and the potential for icing during cold weather. Ice formation has been observed in these tanks recently, increasing the risk of equipment damage. The scope of improvements includes the following:

- Installation of mechanical mixer systems in the City's East and West Elevated Storage Tanks.

Scope of Services

Fishbeck proposes to provide construction administration services for the tasks outlined. It should be noted that TetraTech will provide construction administration services for the electrical portions of the project as a subconsultant to Fishbeck. TetraTech's scope will include construction administration associated with the electrical and instrumentation aspects of the installation of the East and West Elevated Tank Mixers, the installation of well pump motor starters and other electrical equipment for 16 source wells, and the electrical and instrumentation aspects of the new magnetic flow meter on the WTP return flow pipeline.

Construction Administration Services

Fishbeck proposes to provide construction administration services to complete all the tasks outlined in this proposal:

1. Review the Contractor's bond and insurance information and assist the City in the execution of the contract documents by providing the necessary forms and documents.
2. Conduct a preconstruction meeting with contractors and Owner representatives. Meetings will be held at the Jackson Water Treatment Plant. Engineers from Fishbeck will attend.
3. Review the Contractor's schedule information.
4. Participate in project progress meetings, as necessary. Monthly meetings at the WTP are assumed. Our scope assumes Fishbeck will attend up to 14 progress meeting and TetraTech will attend up to six progress meetings.
5. Respond in writing to Contractor's Requests for Information and issue clarifications and interpretations to the contract documents, as applicable, including recommending change orders and work change directives to the Owner as applicable.
6. Review detailed project submittals, including construction drawings, shop drawings, erection drawings, samples, schedule information, and other data that the Contractor is required to submit for compliance with design concepts and American Iron and Steel requirements.
7. Consult and advise the City as to the acceptability of substitute materials and equipment that may be proposed by the Contractor.
8. Visit the site at intervals appropriate to the various stages of construction and notify the Contractor of defective work, if applicable. Site visits will be conducted by the project manager, the lead engineer or specific discipline engineers, or other qualified personnel dependent on the progress of the work. We have assumed that on average, site visits would need to occur approximately twice per month. Visits would occur more frequently during the busiest periods of contractor work, and there would be some longer periods of time with no site visits during the times that the Contractor is not actively working on site. We have assumed up to 25 visits for Fishbeck staff and 8 visits for TetraTech staff.

9. Provide clarifications and interpretations during the construction. Issue bulletins and change orders, as appropriate.
10. Keep the City informed of the progress of the Work. Review Contractor’s applications for payment and provide recommendations for payment to the City.
11. Fishbeck will review the weekly payroll reports from the Contractor to ensure compliance with Davis-Bacon requirements. Fishbeck will also complete the Davis-Bacon interviews as necessary to comply with requirements. Fishbeck will also complete the Davis-Bacon interviews for the contractors associated with the lead service line replacements over the expected three years of lead service line replacement.
12. Make recommendations for the replacement or correction of defective work, as necessary.
13. Engineers from Fishbeck and TetraTech will review the completed work to verify substantial completion and develop a project closeout punch list.
14. Review completed work for final completion and correction of punch list items.
15. Collect and review operation and maintenance manual documentation from the Contractor.
16. Review Contractor project closeout documents, including waivers of lien, consent of surety, and warranties.
17. Conduct a final inspection to verify project completion.
18. Provide project record drawings to the City based on the Contractor’s as-built documentation. Three full-size copies and one electronic copy of the record drawings will be distributed to the City.

Project Staffing

Fishbeck intends to utilize the following key staff for construction administration:

- Project Manager – Dave Baar, PE
- Lead Process Engineer – Colin McCorkle, PE
- Process Engineer – Bailey Papes, PE
- Project Advisor, QAQC – Jeff Brown, PE

Additional staff from the following disciplines will be involved in this project:

- Process, Architectural, Mechanical and Structural.

Tetrattech would provide staff for the construction administration of the electrical and controls portions of the project.

Schedule

The following construction schedule is estimated based on the estimated lead times and construction periods:

Task	Schedule
Bid Advertisement	March 30, 2023
Bid Opening	May 2, 2023
Resolution of Tentative Contract Award	May 26, 2023
EGLE Order of Approval	June 26, 2023
Start of Construction	August 17, 2023*
End of Construction	February 14, 2025*

** Start and end dates of construction are estimated. Given the uncertainty of the bidding climate, these dates are subject to change.*

Assumptions

- The City will provide daily coordination with the Contractor and complete project inspection between visits by the engineering team.

- The City or another consultant secured by the City will handle all aspects of the lead service replacements and water main portions of the DWSRF project, excepting Davis-Bacon weekly payroll and interview reviews for the lead service replacements.
- Programming services are not included in this proposal. Programming services are included as an allowance within the bid documents for this project.

Professional Services Fee

Our fee to complete the work as outlined in the referenced scope of services for an hourly not-to-exceed fee of One Hundred Thirty-Four Thousand Dollars (\$134,000).

Authorization

Attached is our Professional Services Agreement. If you concur with our scope of services, please sign in the space provided and return the executed contract to the attention of Darcy McWilliams (dmcwilliams@fishbeck.com). This proposal is made subject to the attached Terms and Conditions for Professional Services. Invoices will be submitted every four weeks and payment is due upon receipt.

If you have any questions or require additional information, please contact me at 616.464.3825 or cmccorkle@fishbeck.com.

Sincerely,



Colin G. McCorkle, PE
Senior Water and Wastewater Engineer



David J. Baar, PE
Vice President/Senior Water and Wastewater Engineer

Attachments
By email

Professional Services Agreement

PROJECT NAME DWSRF FY 2023 Improvements – Construction Administration Services
FISHBECK CONTACT David J. Baar, PE
CLIENT City of Jackson
CLIENT CONTACT Mike Osborn
ADDRESS 161 West Michigan Avenue, 11th Floor, Jackson, MI 49201

Client hereby requests and authorizes Fishbeck to perform the following:

SCOPE OF SERVICES: Perform Construction Administration Services in accordance with the attached Fishbeck Proposal Letter, dated June 13, 2023.

AGREEMENT. The Agreement consists of this page and the documents that are checked:

- Terms and Conditions for Professional Services, attached.
- Proposal dated June 13, 2023.
- Other:

METHOD OF COMPENSATION:

- Lump Sum for Defined Scope of Services
- Hourly Billing Rates plus Reimbursable Expenses
- Other:

Budget for Above Scope of Services: Our fee to complete the work as outlined in the referenced scope of services for an hourly not-to-exceed fee of One Hundred Thirty-Four Thousand Dollars (\$134,000).

ADDITIONAL PROVISIONS (IF ANY): None.

APPROVED FOR:

City of Jackson

BY: _____

TITLE: _____

DATE: _____

ACCEPTED FOR:

Fishbeck

BY:  _____

Vice President/Senior Water and
 Wastewater Engineer

TITLE: _____

DATE: June 13, 2023

1. **METHOD OF AUTHORIZATION.** Client may authorize Fishbeck to proceed with work either by signing a Professional Services Agreement or by issuance of an acknowledgment, confirmation, purchase order, or other communication. Regardless of the method used, these Terms and Conditions shall prevail as the basis of Client’s authorization to Fishbeck. Any Client document or communication in addition to or in conflict with these Terms and Conditions is rejected.
2. **CLIENT RESPONSIBILITIES.** Client shall provide all criteria and full information as to requirements for the Project and designate in writing a person with authority to act on Client’s behalf on all matters concerning the Project. If Fishbeck’s services under this Agreement do not include full-time construction observation or review of Contractor’s performance, Client shall assume responsibility for interpretation of contract documents and for construction observation, and shall waive all claims against Fishbeck that may be in any way connected thereto.
3. **HOURLY BILLING RATES.** Unless stipulated otherwise, Client shall compensate Fishbeck at hourly billing rates in effect when services are provided by Fishbeck employees of various classifications.
4. **REIMBURSABLE EXPENSES.** Those costs incurred on or directly for Client’s Project. Reimbursement shall be at Fishbeck’s current rate for mileage for service vehicles and automobiles, special equipment, and copying, printing, and binding. Reimbursement for commercial transportation, meals, lodging, special fees, licenses, permits, insurances, etc., and outside technical or professional services shall be on the basis of actual charges plus 10 percent.
5. **OPINIONS OF COST.** Any opinions of probable construction cost and/or total project cost provided by Fishbeck will be on a basis of experience and judgment, but since it has no control over market conditions or bidding procedures, Fishbeck cannot warrant that bids or ultimate construction or total project costs will not vary from such estimates.
6. **PROFESSIONAL STANDARDS; WARRANTY.** The standard of care for services performed or furnished by Fishbeck will be the care and skill ordinarily used by members of Fishbeck’s profession practicing under similar circumstances at the same time and in the same locality. Fishbeck makes no warranties, express or implied, under this Agreement or otherwise, in connection with Fishbeck’s services.
7. **TERMINATION.** Either Client or Fishbeck may terminate this Agreement by giving ten days’ written notice to the other party. In such event, Client shall pay Fishbeck in full for all work previously authorized and performed prior to the effective date of termination, plus (at the discretion of Fishbeck) a termination charge to cover finalization work necessary to bring ongoing work to a logical conclusion. Such charge shall not exceed 30 percent of all charges previously incurred. Upon receipt of such payment, Fishbeck will return to Client all documents and information which are the property of Client.
8. **SUBCONTRACTORS.** Fishbeck may engage subcontractors on behalf of Client to perform any portion of the services to be provided by Fishbeck hereunder.
9. **PAYMENT TO FISHBECK.** Invoices will be issued every four weeks, payable upon receipt, unless otherwise agreed. Interest of 1 percent per four-week period will be payable on all amounts not paid within 28 days from date of invoice, payment thereafter to be applied first to accrued interest and then to the principal unpaid amount. Any attorney’s fees or other costs incurred in collecting any delinquent amount shall be paid by Client.

Client agrees to pay on a current basis, in addition to any proposal or contract fee understandings, all taxes including, but not limited to, sales taxes on services or related expenses which may be imposed on Fishbeck by any governmental entity.

If Client directs Fishbeck to invoice another, Fishbeck will do so, but Client agrees to be ultimately responsible for Fishbeck’s compensation until Client provides Fishbeck with that third party’s written acceptance of all terms of this Agreement and until Fishbeck agrees to the substitution.

In addition to any other remedies Fishbeck may have, Fishbeck shall have the absolute right to cease performing any basic or additional services in the event payment has not been made on a current basis.

10. **HAZARDOUS WASTE.** Fishbeck has neither created nor contributed to the creation or existence of any hazardous, radioactive, toxic, irritant, pollutant, or otherwise dangerous substance or condition at any site, and its compensation hereunder is in no way commensurate with the potential risk of injury or loss that may be caused by exposure to such substances or conditions. Fishbeck shall not be responsible for any alleged contamination, whether such contamination occurred in the past, is occurring presently, or will occur in the future, and the performance of services hereunder does not imply risk-sharing on the part of Fishbeck.
11. **LIMITATION OF LIABILITY.** To the fullest extent permitted by law, Fishbeck’s total liability to Client for any cause or combination of causes, which arise out of claims based upon professional liability errors or omissions, whether based upon contract, warranty, negligence, strict liability, or otherwise is, in the aggregate, limited to the greater of \$250,000 or the amount of the fee earned under this Agreement.

To the fullest extent permitted by law, Fishbeck’s total liability to Client for any cause or combination of causes, which arise out of claims for which Fishbeck is covered by insurance other than professional liability errors and omissions, whether based upon contract, warranty, negligence, strict liability, or otherwise is, in the aggregate, limited to the total insurance proceeds paid on behalf of or to Fishbeck by Fishbeck’s insurers in settlement or satisfaction of Client’s claims under the terms and conditions of Fishbeck’s insurance policies applicable thereto.

Higher limits of liability may be considered upon Client’s written request, prior to commencement of services, and agreement to pay an additional fee.

12. **DELEGATED DESIGN.** Client recognizes and holds Fishbeck harmless for the performance of certain components of the Project which are traditionally specified to be designed by the Contractor.
13. **INSURANCE.** Client shall cause Fishbeck and Fishbeck's consultants, employees, and agents to be listed as additional insureds on all commercial general liability and property insurance policies carried by Client which are applicable to the Project. Client shall also provide workers' compensation insurance for Client's employees. Client agrees to have their insurers endorse these insurance policies to reflect that, in the event of payment of any loss or damages, subrogation rights under this Agreement are hereby waived by the insurer with respect to claims against Fishbeck.

Upon request, Client and Fishbeck shall each deliver to the other certificates of insurance evidencing their coverages.

Client shall require Contractor to purchase and maintain commercial general liability and other insurance as specified in the contract documents and to cause Fishbeck and Fishbeck's consultants, employees, and agents to be listed as additional insureds with respect to such liability and other insurance purchased and maintained by Contractor for the Project. Contractor must agree to have their insurers endorse these insurance policies to reflect that, in the event of payment of any loss or damages, subrogation rights under this Agreement are hereby waived by the insurer with respect to claims against Fishbeck.

14. **INDEMNIFICATION.** Fishbeck will defend, indemnify, and hold Client harmless from any claim, liability, or defense cost for injury or loss sustained by any party from exposures to the extent caused by Fishbeck's negligence or willful misconduct. Client agrees to defend, indemnify, and hold Fishbeck harmless from any claim, liability, or defense cost for injury or loss sustained by any party from exposures allegedly caused by Fishbeck's performance of services hereunder, except for injury or loss to the extent caused by the negligence or willful misconduct of Fishbeck. These indemnities are subject to specific limitations provided for in this Agreement.
15. **CONSEQUENTIAL DAMAGES.** Client and Fishbeck waive consequential damages for claims, disputes, or other matters in question relating to this Agreement including, but not limited to, loss of business.
16. **LEGAL EXPENSES.** If either Client or Fishbeck makes a claim against the other as to issues arising out of the performance of this Agreement, the prevailing party will be entitled to recover its reasonable expenses of litigation, including reasonable attorney's fees. If Fishbeck brings a lawsuit against Client to collect invoiced fees and expenses, Client agrees to pay Fishbeck's reasonable collection expenses including attorney fees.
17. **OWNERSHIP OF WORK PRODUCT.** Fishbeck shall remain the owner of all drawings, reports, and other material provided to Client, whether in hard copy or electronic media form. Client shall be authorized to use the copies provided by Fishbeck only in connection with the Project. Any other use or reuse by Client or others for any purpose whatsoever shall be at Client's risk and full legal responsibility, without liability to Fishbeck. Client shall defend, indemnify, and hold harmless Fishbeck from all claims, damages, losses, and expenses, including attorney's fees arising out of or resulting therefrom.
18. **ELECTRONIC MEDIA.** Data, reports, drawings, specifications, and other material and deliverables may be transmitted to Client in either hard copy, digital, or both formats. If transmitted electronically, and a discrepancy or conflict with the electronically transmitted version occurs, the hard copy in Fishbeck's files used to create the digital version shall govern. If a hard copy does not exist, the version of the material or document residing on Fishbeck's computer network shall govern. Fishbeck cannot guarantee the longevity of any material transmitted electronically nor can Fishbeck guarantee the ability of the Client to open and use the digital versions of the documents in the future.
19. **GENERAL CONSIDERATIONS.** Client and Fishbeck each are hereby bound and the partners, successors, executors, administrators, and legal representatives of Client and Fishbeck are hereby bound to the other party to this Agreement and to the partners, successors, executors, administrators, and legal representatives (and said assigns) of such other party, in respect of all covenants, agreements, and obligations of this Agreement.

Neither Client nor Fishbeck shall assign this Agreement without the written consent of the other.

Neither Client nor Fishbeck will have any liability for nonperformance caused in whole or in part by causes beyond Fishbeck's reasonable control. Such causes include, but are not limited to, Acts of God, civil unrest and war, labor unrest and strikes, acts of authorities, and events that could not be reasonably anticipated.

This Agreement shall be governed by the law of the principal place of business of Fishbeck.

This Agreement constitutes the entire agreement between Client and Fishbeck and supersedes all prior written or oral understandings. This Agreement may only be amended, supplemented, modified, or canceled by a duly executed written instrument.

End of Terms and Conditions for Professional Services

MEMO TO: Mayor and City Councilmembers
FROM: Jonathan Greene, City Manager
DATE: July 11, 2023
SUBJECT: **Region 2 Planning Commission Invoice – Local Share Cost of JACTS Unified Work Program FY 2023**

Recommendation:

Approve payment of the invoice from Region 2 Planning Commission for local share cost of Jackson Area Comprehensive Transportation Study (JACTS) Unified Work Program for FY 2022, in the amount of \$24,508.00, in accordance with the recommendation of the City Engineer, and authorize the City Engineer to sign the Local Funding Resolution.

Attached is a report from Jon Dowling, City Engineer, regarding approval of payment to JACTS for the City's local share cost of the JACTS Unified Work Program for FY 2023, and authorization to sign the resolution.

I recommend approval of the payment and resolution. Your consideration and concurrence is appreciated.

JG

Attachments

DEPARTMENTAL REPORT

MEMO TO: Jonathan Greene, City Manager
FROM: Jon H. Dowling, P.E., City Engineer
DATE: July 11, 2023

RECOMMENDATION: Approve payment of the invoice from Region 2 Planning Commission for local share cost of Jackson Area Comprehensive Transportation Study (JACTS) Unified Work Program for FY 2023, in the amount of \$24,508.00, in accordance with the recommendation of the City Engineer, and authorize the City Engineer to sign the Local Funding Resolution.

SUMMARY

The attached invoice and funding resolution from Region 2 Planning Commission is for the local agencies' matching requirement for the fiscal year 2023 JACTS Unified Work Program.

BUDGETARY CONSIDERATIONS

This invoice of \$24,508.00 will be paid from the Major Street Fund.

HISTORY, BACKGROUND and DISCUSSION

Originally this cost was a soft match to Region 2 with City staff working in conjunction with the Unified Work Program. Years ago, the Federal Highway Commission changed their policy and wanted to see actual payments from the local agencies to the planning agencies. Since FY2010-2011, this has appeared in the City's budget in Major Street Fund Street and Bridge Construction (202-451) for JACTS Planning Region 2.

DISCUSSION OF THE ISSUE

Region 2 Planning Commission is the state designated Metropolitan Planning Organization (MPO) for the Jackson urbanized area. The MPO oversees the Unified Work Program and receives planning funds from the Federal Highway Administration. These planning funds are required to have a local match of 18.15%. This local match is split between the City and the County Department of Transportation.

POSITIONS

I request approval of payment of the invoice and authorization for the City Engineer to sign the resolution.

JHD/sms

Attachments

Region 2

PLANNING COMMISSION

Serving Hillsdale, Jackson & Lenawee Counties

TO: Jon Dowling, City of Jackson; Michael Brown, Jackson Area Transportation Authority; and Angie Kline, Jackson County Department of Transportation

FROM: Jacob Hurt, Executive Director

RE: JACTS FY 2023 Unified Work Program Local Matching Funds

DATE: June 28, 2023

Attached, please find an invoice and funding resolution for the local Act 51 agencies' match requirement for the FY 2023 JACTS Unified Work Program. Please sign and date the resolution and return to me along with your payment. I will forward a copy of the resolution to you once I obtain our R2PC Chair's signature.

Let me know if you have any questions.

Thanks for your on-going assistance and cooperation with the JACTS process.



Serving Hillsdale, Jackson & Lenawee Counties

120 W. Michigan Avenue, 9th Floor
Jackson, MI 49201

Invoice

DATE: June 26, 2023
 INVOICE NO.: 8004
 FOR: FY 2023 Local Share
 Cost

Jon Dowling, Engineering Department
 City of Jackson
 161 W. Michigan Avenue
 Jackson, MI 49201

DESCRIPTION	AMOUNT
City of Jackson Engineering Department Local share cost of JACTS Unified Work Program for FY 2023 (October 1, 2022 - September 30, 2023) Please refer to the enclosed resolution.	\$ 24,508.00
TOTAL	\$ 24,508.00

Make all checks payable to the Region 2 Planning Commission.
 If you have any questions concerning this invoice, please contact
 James Latham, Accountant at 517.768.6710 or email to jlatham@mijackson.org

Thank you.

**REGION 2 PLANNING COMMISSION / JACKSON AREA COMPREHENSIVE
TRANSPORTATION STUDY FY 2023 UNIFIED WORK PROGRAM
LOCAL FUNDING RESOLUTION**

WHEREAS, the urban transportation planning regulations implementing sections of the Fixing America's Surface Transportation (FAST) Act legislation requires that each urbanized area, as a condition of receipt of Federal capital or operating assistance, have a continuing, cooperative, and comprehensive urban transportation planning process that results in plans and programs consistent with the comprehensively planned development of the urbanized areas; and

WHEREAS, the Region 2 Planning Commission (R2PC), as the state designated Metropolitan Planning Organization (MPO) for the Jackson urbanized area, conducts the continuing, cooperative, and comprehensive planning process through the Jackson Area Comprehensive Transportation Study (JACTS), a forum for cooperative transportation decision-making developed under federal guidelines for the purposes of urban transportation planning conduct; and

WHEREAS, JACTS annually develops an urban transportation Unified Work Program (UWP) which identifies activities and costs necessary for the conduct of the urban transportation planning process; and

WHEREAS, transportation planning funds provided by the U.S. Department of Transportation to the Michigan Department of Transportation and are passed through to the R2PC to carry out the activities defined in the UWP; and

WHEREAS, these funds, available under the FAST Act as Federal Highway Administration (FHWA) PL require a local matching contribution of 18.15 percent; and

WHEREAS, the Region 2 Planning Commission has recommended that the local match contribution required to assure the timely conduct of JACTS activities be divided and contributed equally by the City of Jackson Engineering Department and the Jackson County Department of Transportation; and

WHEREAS, it has been determined that the total local share costs for the JACTS Unified Work Program for FY 2023 (October 1, 2022 – September 30, 2023) is \$49,017;

NOW, THEREFORE BE IT RESOLVED,
That the City of Jackson Engineering Department agrees to participate in 50 percent of the funding of the local share costs by providing \$24,508 to the Region 2 Planning Commission.

BE IT FURTHER RESOLVED,
That the Region 2 Planning Commission agrees to reimburse the City of Jackson Engineering Department for planning activities necessary for the completion of, and identified within, the JACTS FY 2023 Unified Work Program.

Pete Jancek, Chair
Region 2 Planning Commission

Jacob Hurt, Executive Director
Region 2 Planning Commission

Date

Date

Jon H. Dowling, P.E., City Engineer
City of Jackson Engineering Department.

Date

MEMO TO: Mayor and Councilmembers

FROM: Jonathan Greene, City Manager

DATE: July 11, 2023

SUBJECT: **Change Order No. 1 to the Wastewater Treatment Plant Clean Water State Revolving Fund 2022 Improvements Contract with Allied Mechanical Services, Inc.**

Recommendation:

Approval of Change Order No. 1 to the Wastewater Treatment Plant Clean Water State Revolving Fund 2022 Improvements Contract with Allied Mechanical Services, Inc. in the increased amount of \$158,668, and authorize the City Manager and Director of Public Works to execute the appropriate documents.

Your consideration and concurrence are appreciated.

DEPARTMENTAL REPORT

MEMO TO: Jonathan Greene, City Manager

FROM: Michael Osborn, Director of Public Works

DATE: July 11, 2023

RECOMMENDATION: Approval of Change Order No. 1 to the Wastewater Treatment Plant Clean Water State Revolving Fund (CWSRF) 2022 Improvements Contract with Allied Mechanical Services, Inc. in the increased amount of \$158,668, and authorize the City Manager and Director of Public Works to execute the appropriate documents.

SUMMARY

In the fall of 2022, Allied Mechanical Services, Inc. was awarded the project at a contract price of \$11,030,000.00. Since beginning the work, the contractor identified various issues based on existing conditions that need addressing. The items include additional concrete repairs needed to Primary Clarifier Tanks 1–6, changes to the electrical distribution equipment to maintain provisions for backup generator hook-ups, adjustments to the clarifier equipment based on field measurements, and adjustments to the concrete pad and wall penetrations to accommodate the electrical equipment connections. The items also include a credit (deduct) for an alternative electrical equipment option. To proceed with these changes to the existing contract, the change order to modify the contract price requires the approval of City Council.

BUDGETARY CONSIDERATIONS

This change order for the Wastewater Treatment Plant CWSRF 2022 Improvements Contract will be funded using the CWSRF loan contingency along with twenty percent in principal forgiveness.

HISTORY, BACKGROUND and DISCUSSION

The Wastewater Treatment Plant CWSRF 2022 Improvements project work includes replacing equipment, refurbishing Primary Clarifier Tanks 1–6 and 13, and replacing the unit substations that provide all the electrical power distribution, as well as additional improvements at the Wastewater Treatment Plant. Since being awarded the contract and starting work onsite, Allied Mechanical Services, Inc. has continually communicated the field findings and issues with Fishbeck for review and concurrence.

The items comprising this change order represent changes or additional work, labor, or materials, in the project scope which Fishbeck finds warranted. Primary Clarifier Tanks 1–6 are nearly 90 years old and the additional concrete repairs will increase the longevity of the structures. The provisions for the generator hook-ups are necessary to maintain operation of the plant during any power outage. Fishbeck has also reviewed the adjustments to the equipment and found the clarifier weirs and baffles to be necessary to maintain the standard of operation of the treatment process, and the credit for the electrical equipment change to be acceptable in meeting the same equivalent needs. The warranted changes to the contract will have no impact on the contract's existing substantial completion date.

If these necessary changes are not incorporated into this contract, it will compromise the contractor's ability to complete the project to the Fishbeck recommended standards and specifications. Furthermore, hindering our ability to continue to provide a no-fail level of service in the treatment of wastewater to those we serve at the City's Wastewater Treatment Plant.

POSITIONS

Approval of Change Order No. 1 to the Clean Water State Revolving Fund Wastewater Treatment Plant 2022 Improvements Contract with Allied Mechanical Services, Inc., and authorize the City Manager and Director of Public Works to execute the appropriate documents.

**Change Order No. 1
To Contract for
Jackson WWTP CWSRF 2022 Improvements
Wastewater Treatment Plant Jackson, Michigan**

Notice is hereby given that the following additional information and changes shall become a part of the Contract Documents of the above-named contract.

ORIGINAL CONTRACT AMOUNT	\$11,030,000.00
CHANGE ORDER NO. 1	\$158,668.00
NEW CONTRACT AMOUNT AS SET BY Change Order NO. 1	\$11,188,668.00

REASON FOR AMENDMENT:

As outlined in the attached Bulletin No. 1 and Bulletin No. 2 proposals for the additional work, labor, and materials, in the project for the Primary Clarifier Tanks 1–6 and additional concrete repairs needed to increase the longevity of the structures. Provisions for the generator hook ups are necessary to maintain operation of the plant during any power outage. Adjustments to the equipment and the clarifier weirs and baffles are necessary to maintain the standard of operation of the treatment process, and the credit for the electrical equipment change to be acceptable in meeting the same equivalent needs. Allied Mechanical Services, Inc would be able to complete this work without any additional delays to the substantial completion date.

Prepared by Chandra Willinger
Public Works/Utilities Fiscal Supervisor

ACCEPTED BY:

Bob Sweet, Project Manager
Allied Mechanical Service, Inc

Date:

ACCEPTED BY:

Michael Osborn, Director of Public Works

Date:

ACCEPTED BY:

Jonathan Greene, City Manager

Date:

CHANGE ORDER
PAGE 1 OF 3

CONTRACT FOR: WWTP CWSRF 2022 Improvements
OWNER: City of Jackson
161 West Michigan Avenue
Jackson, MI 49201
CONTRACTOR: Allied Mechanical Services, Inc.
3860 Roger B Chaffee Memorial Dr., SE
Grand Rapids, MI 49548
ENGINEER: Fishbeck
39500 MacKenzie Drive, Suite 100
Novi, MI 48377
ATTACHMENTS: Bulletin No. 1, Bulletin No. 2, Proposals from AMS

YOU ARE DIRECTED TO MAKE THE FOLLOWING CHANGES IN THE CONTRACT DOCUMENTS:

- A. Incorporate all items identified in Bulletin No. 1:
- ITEM NO. 1: Unit Substation 4 Transformer
Change liquid-filled transformer in Unit Substation 4 to VPE dry type.

DEDUCT: \$12,811.00
- ITEM NO. 2: Temporary Generator Connection Provision
Salvage Owner's generator connection cabinet to avoid interference. Provide 600A camlock connection at Unit Substation 1 for temporary generator connection during demolition of Substation 3.

ADD: \$9,811.00
- ITEM NO. 3: Primary Sludge Building Crack Injection
Provide option for crack injection in the Primary Sludge Building at wall cracks showing signs of corrosion staining and water infiltration.

ADD: \$878.00
- ITEM NO. 4: Clarifier Tank Wall Cap Repair
Repair area of removed tank wall cap.

ADD: \$5,384.00
- ITEM NO. 5: Clarifier Tank Concrete Crack and Spall Repairs
Adjust quantity of concrete to be removed and replaced to 78 square feet total, including 19 square feet overhead repairs. Add 102 linear feet of crack injection.

ADD: \$38,124.00
- ITEM NO. 6: Clarifier Tank Concrete Repairs
Add patching of 3 holes, typical 6 tanks.

ADD: \$3,014.00
- ITEM NO. 7: Exterior Lights
Replace exterior lights at Primary Clarifier Tanks 1-6.

ADD: \$50,564.00

CHANGE ORDER
 PAGE 2 OF 3

ITEM NO. 8: Substation 4 Equipment Pad
 Increase concrete pad for Unit Substation 4. Adjust grading around pad to provide drainage.

ADD: \$2,180.00

- B. Incorporate Change Request Proposal dated May 30, 2023.
 Proposal regarding "Permanent Generator Connection Point in New Sub 1" dated May 30, 2023, is approved to change the kirk key location in Unit Substation 1 to allow a 1200 A generator connection.

ADD: \$968.00

- C. Incorporate Change Request Proposal dated June 7, 2023.
 Proposal regarding "RFI #27 Scum Line from Clarifier 7-12" dated June 7, 2023, is approved for plugging the scum pipe from Primary Clarifiers 7-12 to isolate excess flow to the scum wet well.

ADD: \$1,692.00

- D. Incorporate Change Request Proposal dated June 8, 2023.
 Proposal regarding "Weir and Baffles" dated June 8, 2023, is approved for adjusting the weirs and baffles sizes based on field conditions for Primary Clarifiers 1-6 and 13 to maintain design water levels and tank operation.

ADD: \$25,047.00

- E. Incorporate Change Request Proposal dated June 26, 2023.
 Proposal regarding "RFI #31 Scum Wall Sleeves Clarifiers 1-6" dated June 26, 2023, is approved for surface preparation and coating the scum pipe wall sleeves in Primary Clarifiers 1-6 due to existing conditions.

ADD: \$7,777.00

- F. Incorporate all items identified in Bulletin No. 2:
ITEM NO. 1: Cable Tray Penetrations
 Remove existing electrical busway and provide masonry wall infill where removed. Provide wall penetrations with lintels for new cable tray at two additional locations.

ADD: \$26,040.00

CHANGE IN CONTRACT PRICE:

Original Contract Price:

\$11,030,000.00

Previous Change Order No.: N/A

\$0

Contract Price prior to this Change Order:

\$11,030,000.00

Net increase of this Change Order:

\$158,668.00

Contract Price with all approved Change Orders:

\$11,188,668.00

CHANGE IN CONTRACT TIMES:

Original Contract time:

Substantial Completion: March 1, 2024

Ready for final payment: April 30, 2024

Net change from previous Change Orders:

0 Days

Contract Time prior to this Change Order:

Substantial Completion: March 1, 2024

Ready for final payment: April 30, 2024

Net change of this Change Order:

0 Days

Contract Time with all approved Change Orders:

Substantial Completion: March 1, 2024

Ready for final payment: April 30, 2024

CHANGE ORDER
PAGE 3 OF 3

RECOMMENDED

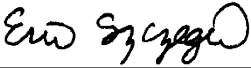
By: 
Engineer

Erin H. Szczegielniak, PE,
Project Manager
Name and Title of Signatory

Date: June 29, 2023

END OF CHANGE ORDER

BULLETIN
PAGE 1 OF 3

CONTRACT FOR:	WWTP CWSRF 2022 Improvements
OWNER:	City of Jackson 161 West Michigan Avenue Jackson, MI 49201
CONTRACTOR:	Allied Mechanical Services, Inc. 3860 Roger B Chaffee Memorial Dr., SE Grand Rapids, MI 49548
ENGINEER:	Fishbeck 39500 MacKenzie Drive, Suite 100 Novi, MI 48377
DRAWING REVISION NO.:	B1
ISSUED HEREWITH:	
SPECIFICATION SECTIONS:	None
SHEETS:	C401, S101, E101

The items below are being considered as possible changes to the Contract Documents for this Project. Contractor is requested to submit changes in cost, if any, for each item and indicate whether it is an addition to or deduction from the Contract Price. Costs are requested as lump sums unless otherwise noted as a unit cost. Include all labor, materials, overhead and profit, trades, subcontractors, and related costs. After reviewing the effects of those changes in the Work, Owner may issue a Change Order specifying which changes are to be incorporated in the Work, if any.

This Bulletin is not a Change Order and is not to be deemed authorization to proceed with the changes listed.

Additional work or materials, where proposed, shall meet the requirements of the Contract Documents, except where noted.

Contractor is responsible for notifying Engineer, in writing, concerning any revision or clarification which causes a change in the Contract Documents, but not specifically mentioned as a cost item in this Bulletin.

Return one completed and signed copy of the Bulletin to Engineer on or before the due date noted above.

Each proposed change has been described briefly with additional information provided concerning detailed changes required for the major trades concerned. Only one total cost figure has been requested for each item on the Bulletin; however, a complete breakdown is required for each item as supporting documentation. This will allow Owner to more easily evaluate the proposed cost changes. Each Bulletin item is an all-inclusive item and may concern work from several trades or Subcontractors. It is Contractor's responsibility to ensure that all work for each item has been included in the total cost figure provided to Owner.

ITEM NO. 1: Unit Substation 4 Transformer

Section: 26 11 16.11 – Secondary Unit Substations – Secondary Less than 1000V (not reissued)

- A. Change liquid-filled transformer in Unit Substation 4 to VPE dry type. Provide VPE transformers as recommended by manufacturer for installed location.

ADD/~~DEDUCT~~ \$ (12,811.00)

BULLETIN
PAGE 2 OF 3

ITEM NO. 2: Temporary Generator Connection Provision
Sheets: E003 – Partial One Line Diagram (not reissued)
E201 – Blower Building Electrical Plans (not reissued)

- A. Disconnect and salvage generator connection cabinet to avoid interference with EAL-201. Return connection cabinet to Owner.
- B. Prior to demolition of Unit Substation 3, provide 600A camlock connection cabinet and connect cabinet to Unit Substation 1. Install Owner's spare 600A circuit breaker in Unit Substation 1 for connection of camlock feeders. Install new conduit (or use cable tray) and conductors between camlock connection and 600A breaker. Install bottom of camlocks at 30 inches AFF if possible; do not install bottom of camlocks lower than 18 inches AFF.

~~ADD~~ DEDUCT: \$ 9,811.00

ITEM NO. 3: Primary Sludge Building Crack Injection
RFI: RFI 29 – Building Infiltration (not reissued)

- A. Provide crack injection at two locations in the lower level (pump room) of the Primary Sludge Building at wall cracks showing signs of steel corrosion staining and water infiltration, as noted previously in RFI 29.

~~ADD~~ DEDUCT: \$ 878.00
~~or \$1,582.00~~

ITEM NO. 4: Clarifier Tank Wall Cap Repair
Sheet: S101 – Primary Clarifiers 1-6 (reissued)

- A. Repair area of removed wall cap. See S101 for detail.

~~ADD~~ DEDUCT: \$ 5,384.00

ITEM NO. 5: Clarifier Tank Concrete Crack and Spall Repairs
Sheets: S101 – Primary Clarifiers 1-6 (reissued)
S102 – Primary Clarifiers 1-6 Top Slab (not reissued)

- A. Adjust quantity of concrete to be removed and replaced (Keynote 1 repair). Drawings S101 and S102 show 86 SF total repair on horizontal or vertical surfaces. Adjust this quantity to 78 SF total, 19 SF of which are overhead repairs.
- B. Add 102 LF of crack injection (Keynote 3 repair).

~~ADD~~ DEDUCT: \$ 38,124.00

ITEM NO. 6: Clarifier Tank Concrete Repairs
Sheet: S102 – Primary Clarifiers 1-6 Top Slab (not reissued)
RFI: RFI 39 – Clarifiers 1-6 Slab Hole Repair (not reissued)

- A. Add patching of 3 holes, typical 6 tanks. Not on Drawings, refer to RFI 39.

~~ADD~~ DEDUCT: \$ 3,014.00

ITEM NO. 7: Exterior Lights
Sheets: E001 – Legends, General Notes, and Schedules (not issued)
E101 – Primary Sludge Building Electrical Plans (reissued)

- A. Replace exterior lights at Primary Clarifier Tanks 1-6. Provide type 'C' fixture Red Sky #RND-40-100/277-4000k-CLR-GREY-SN25 fixtures. Provide each type 'C' fixture with a telescoping safety pole Eaton #V65-H-MHK-RTS-A-C-PM5. See Sheet E101 for installation requirements.

~~ADD~~ DEDUCT: \$ 50,564.00

BULLETIN
PAGE 3 OF 3

ITEM NO. 8: Substation 4 Equipment Pad
Sheet: C401 – Unit Substation 4 Layout and Utility Plan (reissued)

- A. Increase concrete pad for Unit Substation 4. Provide cut and fill as necessary. Adjust grading around pad to provide drainage. See Sheet C401.

ADD/DEDUCT: \$ 2,180.00

Contractor:

Bob Sweet  Digitally signed by Bob Sweet

Signature

Project Manager

Name and Title of Signatory

6-8-23







Date

END OF BULLETIN

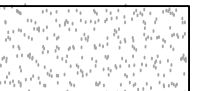
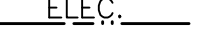
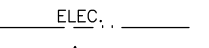
BENCH MARKS

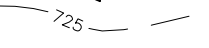
BENCH MARK A ELEVATION: 925.52
SW CORNER OF CONCRETE SLAB ON
SOUTH SIDE OF BRICK BUILDING AT
NW CORNER OF LARGE RETENTION BASIN,
EAST SIDE OF WWTP

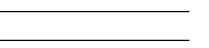
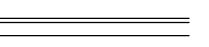
SYMBOL LEGEND

-  ASPHALT PAVEMENT
-  CONCRETE PAVEMENT
-  PROPOSED ELECTRIC
-  EXISTING UNDERGROUND ELECTRIC
-  BENCH MARK
-  CONTOUR MAJOR
-  CONTOUR MINOR
-  PAVED SURFACE
-  EXISTING CURB & GUTTER
-  GRADE ELEVATION
-  TOP OF PAVEMENT

NOTES

1. DIMENSIONS ARE TO FACE OF CURB, OUTSIDE FACE OF BUILDING, AND EDGE OF PAVEMENT UNLESS NOTED OTHERWISE.
2. KEEP THE APPROVED AND/OR MOST CURRENT SET OF PROJECT DRAWINGS ON SITE AT ALL TIMES. CONTRACTOR TO CONFIRM THEY ARE IN POSSESSION OF THE MOST CURRENT DRAWING FILES.
3. EXISTING UTILITY LOCATIONS SHOWN ARE APPROXIMATE.
4. VERIFY THE HORIZONTAL AND VERTICAL LOCATION OF EXISTING UTILITIES PRIOR TO EXCAVATION WHERE NECESSARY.
5. PROTECT AND MAINTAIN SERVICE OF OTHER UTILITIES AT CROSSINGS.
6. PROVIDE AND MAINTAIN INLET FILTERS AT ALL CATCH BASIN INLETS, DURING CONSTRUCTION.
7. RESTORE ALL DISTURBED LAWN AREAS.

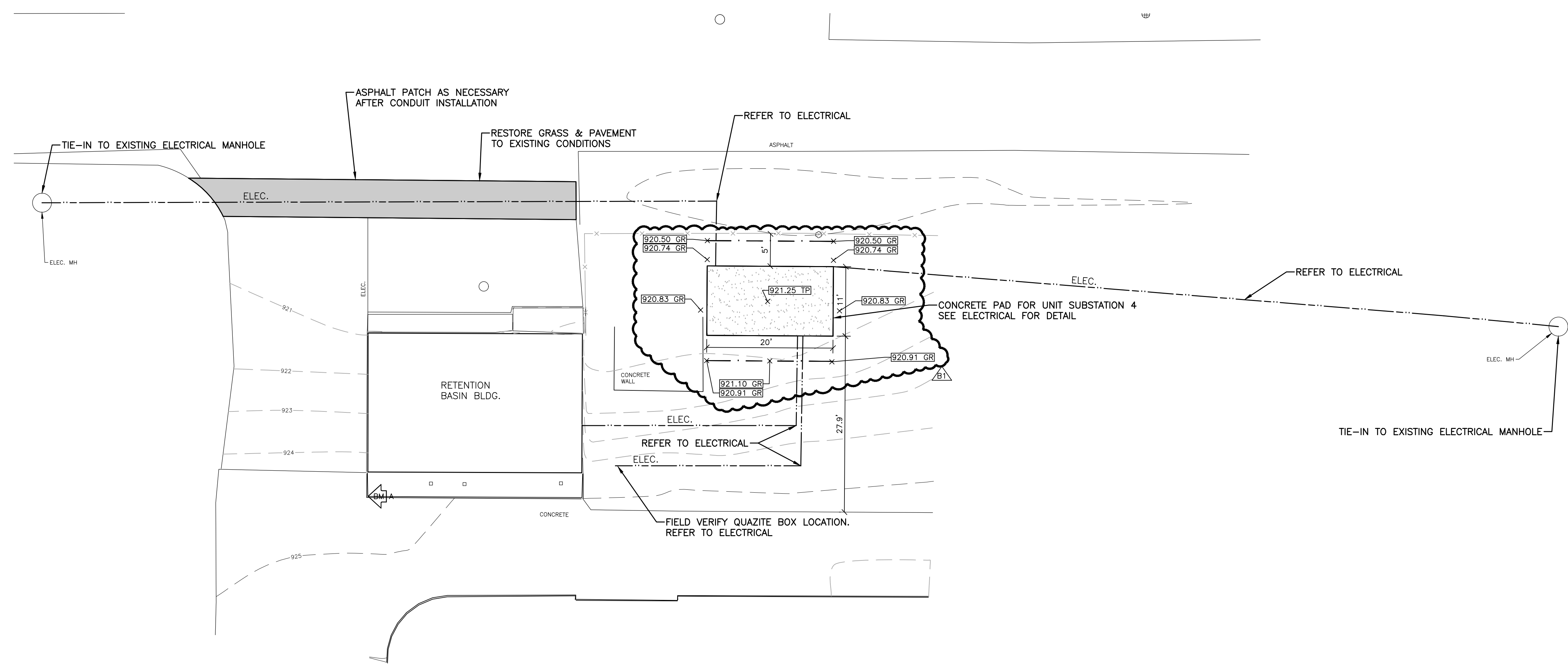

UNIT SUBSTATION 4 LAYOUT & UTILITY PLAN
SCALE: 1" = 10'
NORTH

SITE KEY PLAN



REVISIONS		
02/2023	B1	BULLETIN NO. 1

10/26/2022 FOR CONSTRUCTION	
Drawn By	BEV
Designer	BEV
Reviewer	EJR
Manager	EHS

Hard copy is intended to be 24"x36" when plotted. Scale(s) indicated and graphic quality may not be accurate for any other size.

PROJECT NO.
210403
SHEET NO.

C401

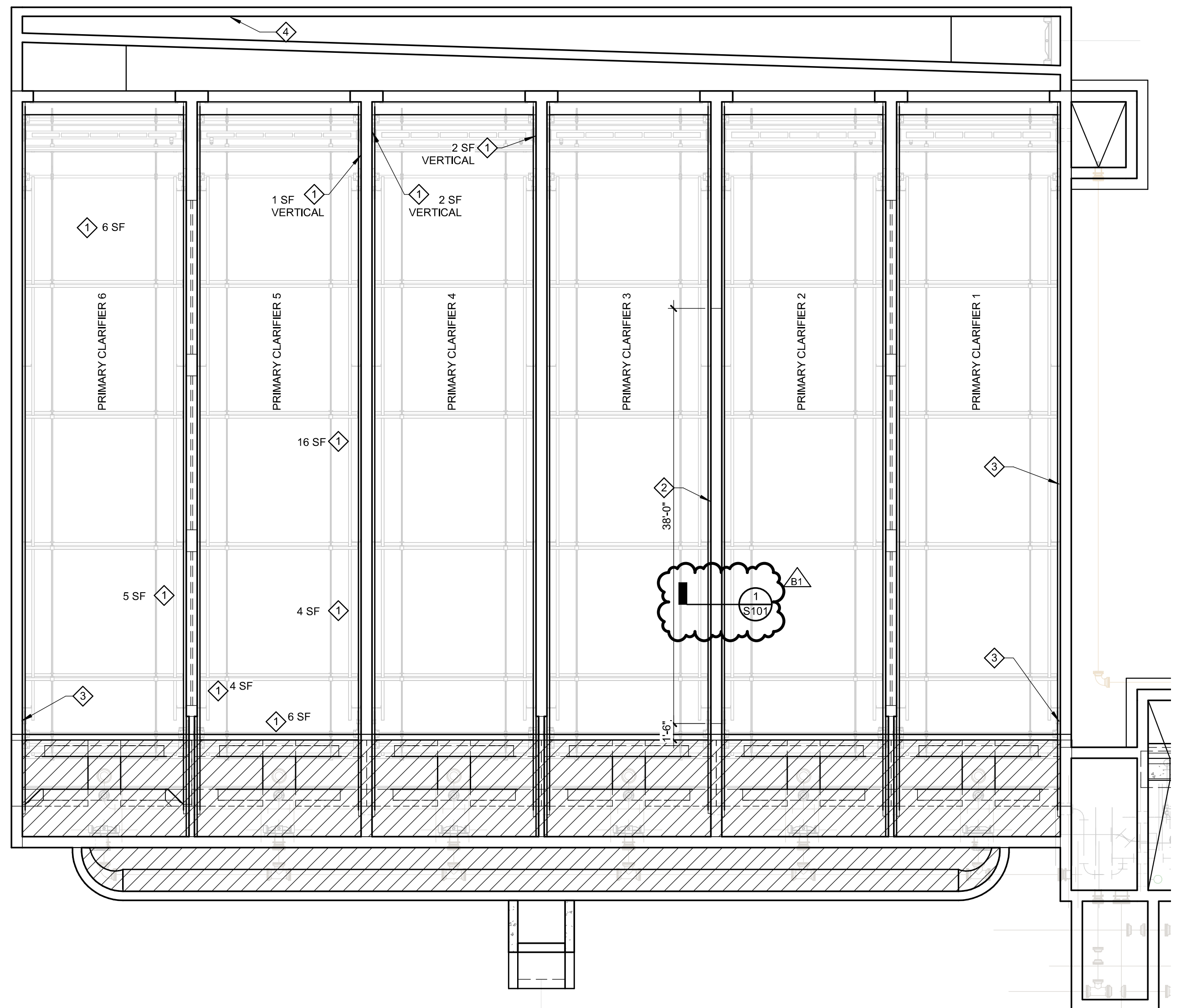
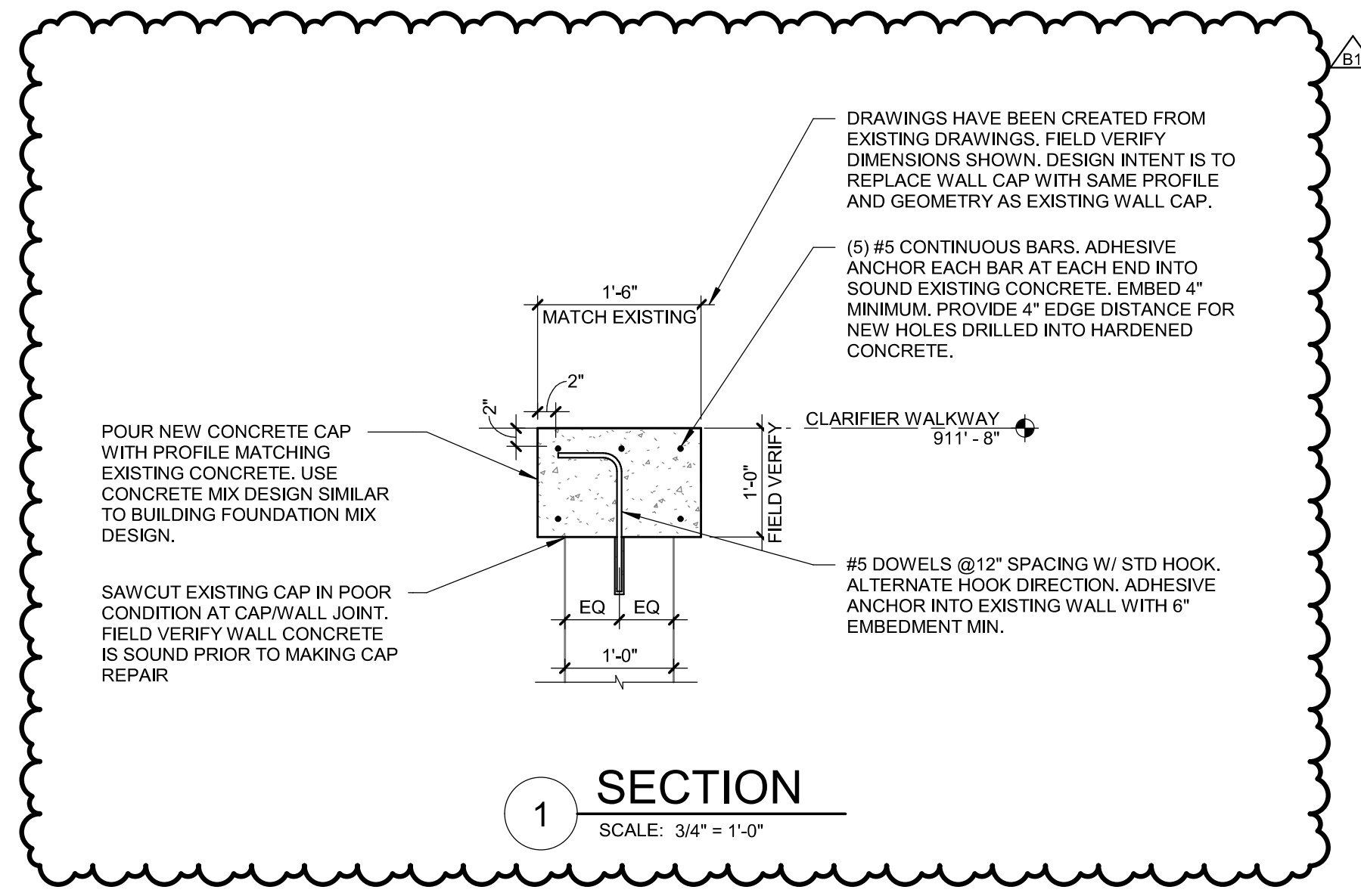

PRIMARY CLARIFIERS 1-6 TANK REPAIRS
SCALE: 1/8" = 1'-0"

- SYMBOLS LEGEND**
- DIAGONAL HATCH REPRESENTS AREAS THAT WERE NOT ACCESSED DURING THE DESIGNERS INSPECTION. ENTER THESE AREAS WHEN ACCESSIBLE DURING CONSTRUCTION AND SOUND CONCRETE SLABS AND WALLS AND REPORT UNSOUND CONCRETE TO ENGINEER. NO REPAIRS ARE ESTIMATED FOR THESE AREAS BASED ON TANK CONDITION IN THE AREAS THAT ARE ACCESSIBLE. DIFFERENCES IN ACTUAL REPAIR QUANTITIES SHOULD BE REPORTED TO OWNER.
 - GROUT HATCH REPRESENTS AREAS THAT ARE TO RECEIVE ELASTOMERIC TRAFFIC COATING, COORDINATE COATING APPLICATION WITH MANUFACTURER INSTALLATION INSTRUCTIONS. USE PRIMER AS RECOMMENDED BY MANUFACTURER BASED ON CONCRETE AND CLIMATE CONDITIONS.

- NOTES**
- TANKS WERE CLEANED PRIOR TO INSPECTION, BUT SOME DEBRIS REMAINED ON THE CONCRETE SURFACES. VERIFY QUANTITIES OF REPAIRS PRIOR TO BEGINNING THE WORK. NOTIFY ENGINEER OF ANY DISCREPANCIES NOTED BETWEEN EXISTING CONDITIONS AND THE DRAWINGS.
 - REPAIR CONCRETE AND APPLY COATING PRIOR TO INSTALLING NEW ALUMINUM RAILING.
 - REPAIR QUANTITIES NOTED ON THIS SHEET ARE A REPRESENTATION OF THE CONCRETE INVESTIGATION DURING THE PROJECT DESIGN PHASE FOR BIDDING PURPOSES. WORK COMPLETED DURING THE PROJECT CONSTRUCTION PHASE WILL VARY FROM WHAT IS SHOWN HERE BASED ON CONTRACTOR'S FIELD INVESTIGATIONS AND COMMUNICATION WITH THE ENGINEER AND OWNER.

- KEY NOTES**
- CONCRETE SPALL OR DELAMINATION, ESTIMATED SQUARE FOOTAGE IS NOTED FOR BIDDING PURPOSES. ACTUAL AMOUNT OF DEGRADATION TO BE FIELD VERIFIED. REPAIR PER TYPICAL CONCRETE REPAIR DETAIL. FOR ESTIMATION PURPOSES, ASSUME SPALL OR DELAMINATION REPAIRS ARE 4" THICK UNLESS NOTED OTHERWISE.
 - SAWCUT AND REMOVE CRACKED WALL CAP.
 - INJECT CRACK WITH POLYURETHANE SEALANT FULL HEIGHT OF WALL AT EXTERIOR WALL.
 - PORTION OF WALL BELOW PIPE HAS CORRODED. REPAIR WALL PER TYPICAL CONCRETE REPAIR DETAIL. VERIFY QUANTITY TO BE REPAIRED. FOR ESTIMATING PURPOSES, ASSUME 4 SQUARE FEET OF WALL FOR THE FULL WALL DEPTH REQUIRE REPAIR.

REVISIONS

6/2/2023	B1	BULLETIN NO. 1
----------	----	----------------

10/26/2022 FOR CONSTRUCTION

Drawn By RJM
Designer TSS
Reviewer CJO
Manager EHS

Hard copy is intended to be 24"x36" when plotted. Scale(s) indicated and graphic quality may not be accurate for any other size.

PROJECT NO.
210403

SHEET NO.

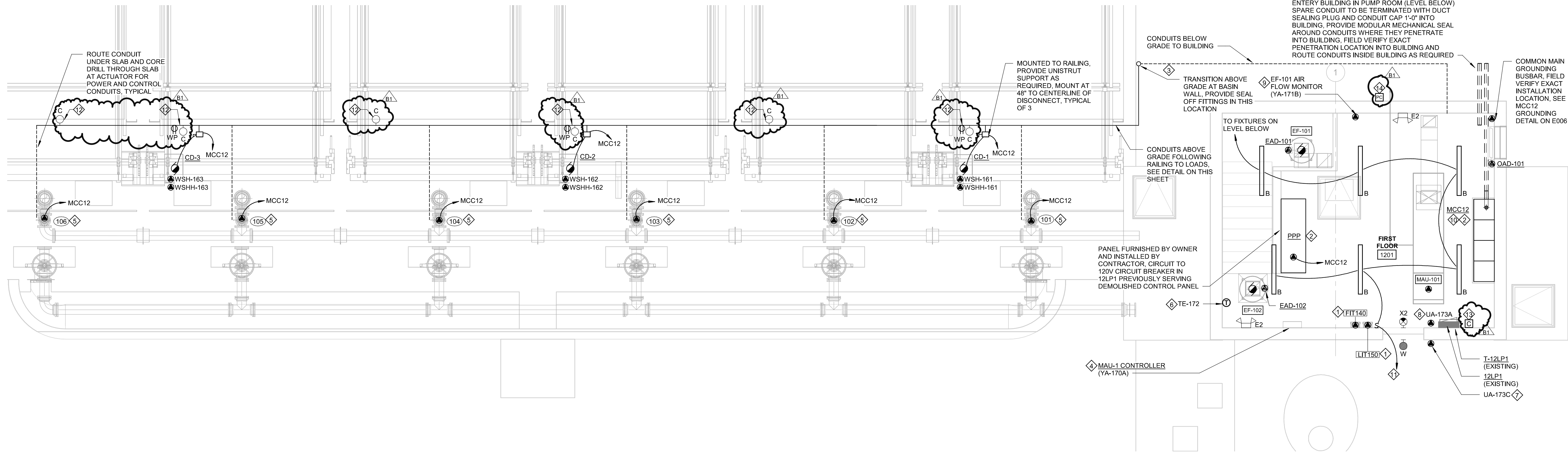

**PRIMARY SLUDGE BUILDING AND CLARIFIER TANKS
UPPER LEVEL ELECTRICAL PLAN**

SCALE: 1/4" = 1'-0"
0 2 4 8

NOTES

- SEE WIRING DIAGRAMS FOR POWERING OF MOTORIZED DAMPERS (EAD-###, OAD-###).
- SCUM WET WELL IS A CLASS I DIVISION 1 HAZARDOUS LOCATION. PROVIDE SEAL OFFS AND INTRINSICALLY SAFE DEVICES AS REQUIRED BY NEC.
- SLUDGE WET WELL IS A CLASS I DIVISION 2 HAZARDOUS LOCATION. PROVIDE SEAL OFFS AND INTRINSICALLY SAFE DEVICES AS REQUIRED BY NEC.
- INTERIOR OF CLARIFIER TANKS AND 18" ABOVE TANK WALLS IS A CLASS I DIVISION 2 HAZARDOUS LOCATION. 18" ABOVE GRADE AND EXTENDING 10'-0" AROUND ALL SIDES OF CLARIFIER TANKS IS A CLASS I DIVISION 2 LOCATION. PROVIDE SEAL OFFS AND INTRINSICALLY SAFE DEVICES AS REQUIRED BY NEC.
- FIELD COORDINATE EXACT INSTALLATION LOCATION OF FIXTURES WITH EXISTING CONDITIONS AND NEW INSTALLATIONS.
- TYPE 'B1' FIXTURES TO BE PENDANT MOUNTED AT 10'-0" AFF TO BOTTOM OF FIXTURE.
- TYPE 'E2' AND 'X1' FIXTURES TO BE WALL MOUNTED AT 8'-0" AFF TO BOTTOM OF FIXTURE.
- TYPE 'W' FIXTURES TO BE MOUNTED SUCH THAT BOTTOM OF FIXTURE IS 6" ABOVE TOP OF ASSOCIATED DOOR FRAME.
- CIRCUIT 'E2', 'X1', AND 'W' FIXTURES TO SAME CIRCUIT. UTILIZE SPARE 1P20 CIRCUIT BREAKER IN 12LP1.

KEY NOTES

- CIRCUIT TO SPARE, 1 POLE, 20A CIRCUIT BREAKER IN 12LP1. BOTH TRANSMITTERS TO BE ON SAME CIRCUIT.
- PROVIDE CONCRETE PAD FOR EQUIPMENT, SEE EQUIPMENT PAD DETAIL ON STRUCTURAL SHEETS.
- FIELD VERIFY EXACT ROUTING TO LOADS. PROVIDE UNISTRUT SUPPORTS SECURED TO TOP OR SIDE OF CONCRETE BASINS AND BASIN RAILING. SUPPORT CONDUIT FROM UNISTRUT. PROVIDE ALL ACCESSORIES AND HARDWARE FOR PROPERLY SECURING UNISTRUT TO CONCRETE. SEE DETAIL ON THIS SHEET. ALL ABOVE GRADE CONDUIT SHALL BE SHALL BE PVC COATED RIGID STEEL. ALL FLEXIBLE CONDUIT SHALL BE LIQUIDTIGHT AND SHALL NOT EXCEED 3'-0" IN LENGTH FOR FINAL CONNECTION TO EQUIPMENT. ALL UNISTRUT SHALL BE PVC COATED. ALL UNISTRUT ACCESSORIES AND HARDWARE SHALL BE PVC COATED WHEN AVAILABLE OR 316 STAINLESS STEEL.
- CIRCUIT TO SPARE, 1 POLE, 20A CIRCUIT BREAKER IN 12LP1. EACH LOAD SHALL HAVE A DEDICATE CIRCUIT UNLESS NOTED OTHERWISE.
- FIELD VERIFY INSTALLATION LOCATION FOR FUSED DISCONNECT SHIPPED LOOSE WITH VALVE ACTUATOR.
- PROVIDE HONEYWELL T775 TEMPERATURE CONTROLLERS WITH (4) SPDT RELAY OUTPUTS AND (2) 4-20mA OUTPUTS. (1) 4-20mA OUTPUT TO BE CONNECTE TO PPP FOR MONITORING ROOM TEMPERATURE. RELAY OUTPUT TO BE CONNECTED TO EF-102 STARTER AS INDICATED IN WIRING DIAGRAMS. HONEYWELL #T775M2030.
- PROVIDE 120VAC, AMBER STROBE, NEMA 4X RATED, WALL MOUNTED, FEDERAL SIGNAL #SLM600A-SLM6W-120-240GY OR EQUAL. MOUNT AT 8'-0" AFF. PROVIDE LAMACOID SIGN WITH RED BACKGROUND AND 2" WHITE LETTERING BELOW STROBE AT 48" ABOVE GRADE TO CENTERLINE THAT READS "WHEN STROBE IS ACTIVE HVAC SYSTEM HAS FAILED AND HAZARDOUS GAS MAY BE PRESENT". 120V POWER PROVIDED VIA PPP.
- PROVIDE 120VAC, COMBINATION AUDIO AND AMBER STROBE, NEMA 4X RATED, WALL MOUNTED, FEDERAL SIGNAL #SLM600A-SLM6W-120-240GY OR EQUAL. MOUNT AT 8'-0" AFF. PROVIDE LAMACOID SIGN WITH RED BACKGROUND AND 2" WHITE LETTERING BELOW STROBE AT 48" AFF TO CENTERLINE THAT READS "WHEN STROBE IS ACTIVE HVAC SYSTEM HAS FAILED AND HAZARDOUS GAS MAY BE PRESENT". 120V POWER PROVIDED VIA PPP.
- PROVIDE 24VDC POWER FROM CONTROL PANEL PPP.
- SEE MCC12 GROUNDING DETAIL ON E006.
- CIRCUIT TO CIRCUIT BREAKER IN 12LP1 SERVING DEMOLISH LIGHT FIXTURES.
- CIRCUIT LIGHT FIXTURES AND RECEPTACLES TO BRANCH CIRCUIT PREVIOUSLY SERVING DEMOLISHED FIXTURES AND RECEPTACLES AT CLARIFIERS. PROVIDE MOUNTING EQUIPMENT AND PVC BACKERBOARD AS REQUIRED FOR MOUNTING RECEPTACLE TO GUARD RAIL. PROVIDE CONDUIT AND MOUNTING HARDWARE AS REQUIRED FOR MOUNTING LIGHT FIXTURE TO GUARD RAIL. BOTTOM OF LIGHT FIXTURE TO BE MOUNTED AT 8'-0" ABOVE TOP OF SLAB. CONDUCTORS TO LIGHT FIXTURES TO BE CIRCUITED TO PHOTOCELL CONTROLLED LIGHTING CONTACTOR. SEE KEYNOTES 13 AND 14. BOTTOM OF RECEPTACLES TO BE MOUNTED A MINIMUM OF 30" ABOVE TOP OF SLAB.
- ELECTRICALLY HELD LIGHTING CONTACTOR FOR CLARIFIER LIGHTING WITH HAND-OFF-AUTO SELECTOR SWITCH IN A NEMA 1 ENCLOSURE. SEE KEYNOTE 12. CONTACTOR RELAY TO BE CONTROLLED BY PHOTOCELL. SEE KEYNOTE 14. CIRCUIT PHOTOCELL AND LIGHTING CONTACTOR RELAY TO SAME 120V CIRCUIT AS CLARIFIER LIGHTING. PROVIDE SCHNEIDER #8903L20V02-C OR EQUAL.
- PHOTOCELL FOR CONTROL OF CLARIFIER LIGHTING CONTACTOR. SEE KEYNOTE 13. PROVIDE INTERMATIC #EK4236S. INSTALL IN ACCORDANCE WITH MANUFACTURER'S INSTALLATION INSTRUCTIONS.

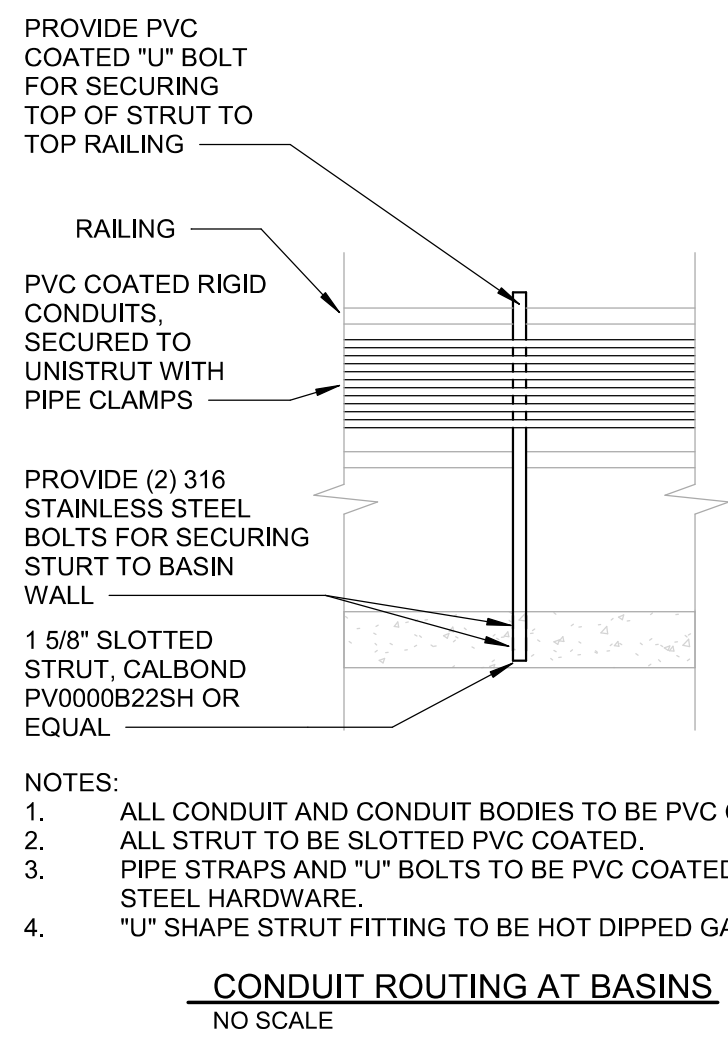

- NOTES:
- ALL CONDUIT AND CONDUIT BODIES TO BE PVC COATED.
 - ALL STRUT TO BE SLOTTED PVC COATED.
 - PIPE STRAPS AND "U" BOLTS TO BE PVC COATED WITH STAINLESS STEEL HARDWARE.
 - "U" SHAPE STRUT FITTING TO BE HOT DIPPED GALVANIZED.
- CONDUIT ROUTING AT BASINS**
NO SCALE

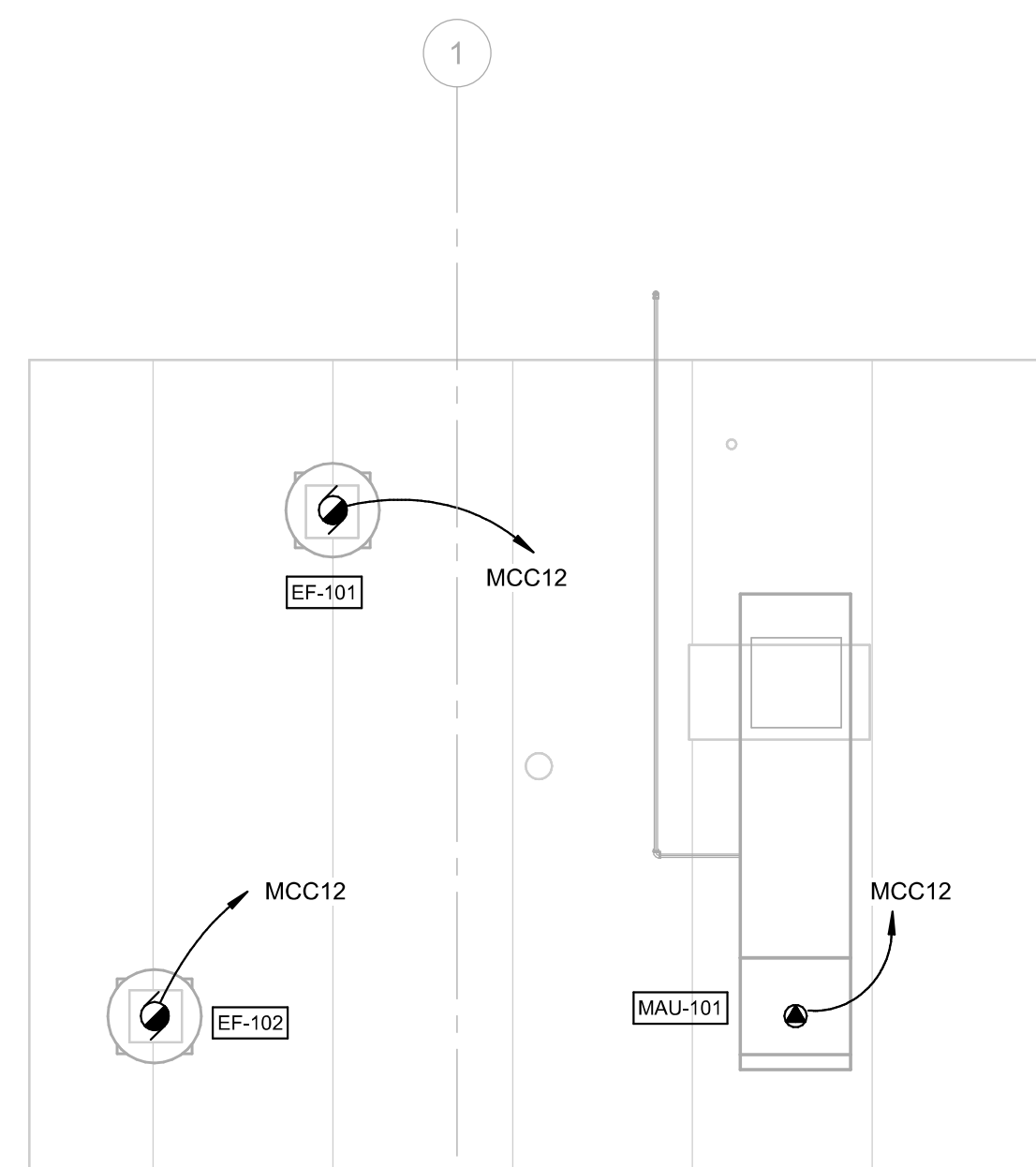

**PRIMARY SLUDGE BUILDING
ROOF POWER PLAN**

SCALE: 1/4" = 1'-0"
0 2 4 8

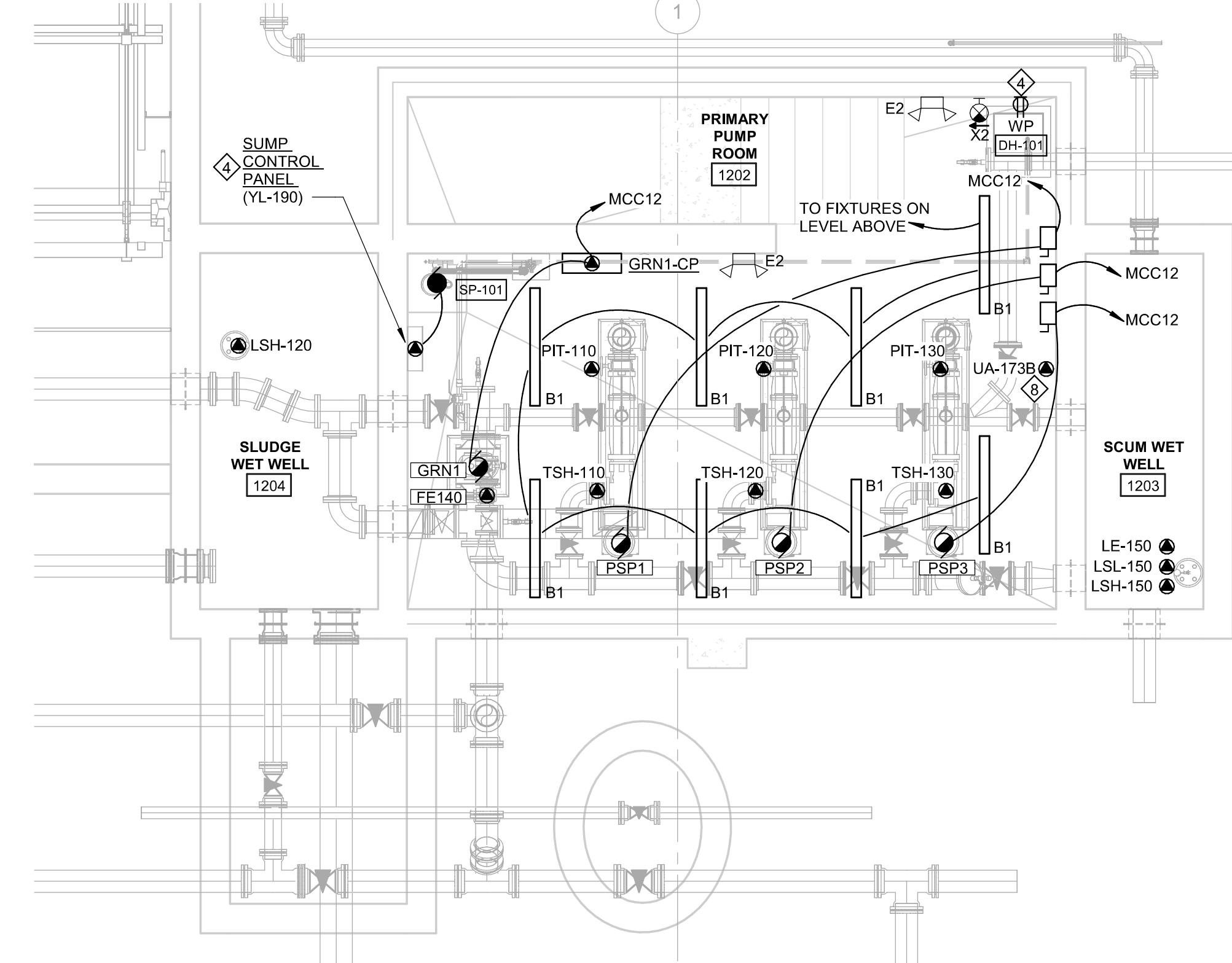

**PRIMARY SLUDGE BUILDING
PUMP ROOM ELECTRICAL PLAN**

SCALE: 1/4" = 1'-0"
0 2 4 8

REVISIONS	
6/1/2023	B1 BULLETIN NO. 1

10/26/2022 FOR CONSTRUCTION	
Drawn By	MJS
Designer	MJS
Reviewer	JAC
Manager	EHS

Hard copy is intended to be 24"x36" when plotted. Scale(s) indicated and graphic quality may not be accurate for any other size.

PROJECT NO.
210403

SHEET NO.
E101



December 10, 2022
Attn: Erin Szczegielniak
Fishbeck
Jackson WWTP CWSRF 2022 Improvements
RE: RFI #1 Sub 4 Transformer

Allied Mechanical Services, Inc. proposes to provide all labor, supervision, and material for the following scope of work.

- Purchase and install (1) VPE Dry Type Transformer in lieu of specified liquid filled transformer per RFI #1 response.

Total Cost Deduct.....(\$12,811.00)

Pricing is firm for 30 days.

Sincerely,

Bob Sweet

Allied Mechanical Services, Inc.
5688 East ML Ave
Kalamazoo, MI 49048
bsweet@alliedmechanical.com
Cell: 269-998-3138

O 517.543.9900
F 517.543.9911

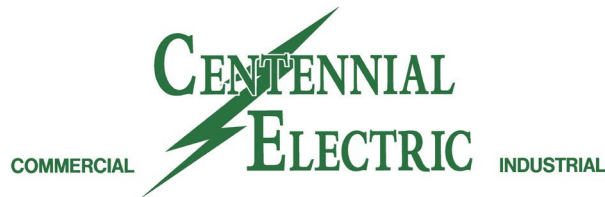

PO BOX 490
POTTERVILLE, MI 48876

11/21/2022

ATT: Bob Sweet
Allied Mechanical Services
5688 E ML Ave.
Kalamazoo, MI 49048

RE: City of Jackson WWTP CWSRF 2022 Improvements- RFI #1 VPE Dry Type Transformer Option for Sub 4

Dear Mr. Sweet,

Centennial Electric, LLC, is pleased to quote you for the above mentioned project. We have included the following:

- VPE Dry Type Transformer which would replace the liquid filled transformer which was originally spec'd due to lead time
- Current estimated lead time on the VPE transformer is 26-28 weeks

Supplier Quotes:	(12,811.00)
Total:	\$ (12,811.00)

Please do not hesitate to contact me with any questions.

Sincerely,

A handwritten signature in black ink that reads 'Trevor Strang'.

Trevor Strang
Project Manager
Centennial Electric LLC



Powering Business Worldwide

12875 Corporate Dr., Unit F
Parma OH, 44130

Change notice quote request

Response to Unit Substation 4 Transformer design

Re: Kendall Electric existing purchase order S112353732

*Eaton C/N Quote Reference# - MGR0011819 – 1
11/18/2022*

Quote description:

The proposed project changes include removing the unit substation 4 transformer liquid design currently supplied on the order with a dry type VPE design.

Current liquid filled transformer description:

Type	:	Liquid-Filled Secondary Unit Substation
Fluid	:	Natural Ester Fluid
Core	:	Grain Oriented Steel
Phase	:	:3 Phase
Frequency	:	60 Hz
Average Winding Rise	:	65 °C
Ambient Temperature	:	:30 °C
High Voltage	:	8320 Delta
High Voltage Taps	:	+2 -2 2.5%
High Voltage BIL	:	95kV BIL
Low Voltage	:	480Y/277
Low Voltage BIL	:	45kV BIL
Low Voltage Neutral	:	X0 bushing with ground strap

Quote details for the dry type VPE transformer design are included on subsequent pages.

Total Net Change Order Net deduct \$ **(-12,811.00)**

(Price excludes any applicable sales tax unless otherwise indicated)

(Proposal validity fifteen days)

Terms and Conditions of sale:

This change notice quote is presented by the Eaton Project Manager Mike Flannery in cooperation with your Eaton Sales Engineer Rich Elfring. This proposal is offered in accordance with the agreed upon terms negotiated under purchase order# S112353732 and Eaton General Order number MGR0011819, and according to Eaton selling policy 25-000 (to download a complete copy of our selling policy please visit our web site at:

<https://www.eaton.com/content/dam/eaton/company/partnering-with-eaton/selling-policies/sp03000001e.pdf>.

Should you wish to proceed with details quoted above, Eaton will require a written change notice or a revised purchase order for the items before the order can be processed. In order to prevent delays in order processing and delivery of products and services, please be sure to accompany any requests for order release with a revised purchase order or written change notice.

Thank you for the opportunity to present you with this proposal and please feel free to contact me with questions or comments anytime.

Sincerely,

Mike Flannery

(412) 638-7938

MikeSFlannery@Eaton.com

Quote ID: EDQ088701-1

Project Name: JACKSON - 2022 WWTP CWSRF IMPROVEMENTS

- Prices quoted may be subject to material cost surcharges for items that ship 45 days past order receipt without prior consent from HPS.
- Prices quoted can be subject to adjustment should Duty and Tariff rates change from time of bid/quotation to time of Product shipment. HPS reserves the right to adjust its pricing for products affected directly or indirectly by changing duties/tariffs/trade agreements.
- Minimum order restrictions may apply.
- All prices quoted are valid ONLY if subsequent order quantity(s) or order release quantity(s) are equal to or greater than the quantity(s) quoted.
- Estimated lead times are subject to material availability and manufacturing capacity at the time of order placement. Customer approval drawings, optional tests and certain equipment options can extend lead times.
- All prices quoted are Ex Works HPS Factory or HPS Warehouse.
- Prepaid freight, when authorized by Seller, will be per either the applicable HPS Customer Freight Policy or HPS Standard Freight Policy. Prepaid freight will only be allowed for one (1) order to one (1) location within North America, with at most two (2) releases. Only complete order line items will be shipped unless otherwise stated on the quotation.
- Prepaid freight, when authorized, will be via Seller's authorized carriers only.
- Where applicable, shipments requiring additional documentation (customs, etc.) will be subject to additional charges (typically for shipments outside North America).
- Special or Custom Products may be combined with Standard Products for prepaid freight with prior Seller's approval only. Otherwise, they will be shipped "Plus Freight".
- All weekend shipments to Buyer will have a service charge applied to the order in addition to any other shipping and order charges.

Item #1:

Quantity: 1

Technical Particulars:

VPE - Epoxy Construction
Rating: 750kVA
Frequency: 60Hz
Phase: 3
Primary Voltage: 8320V Delta
Primary BIL: 95kV
Primary Taps: (2)+2.5% FCAN; (2)-2.5% FCBN
Secondary Voltage: 480Y/277
Secondary BIL: 45kV
Impedance: 5.75% (+/- std tol)
Conductor Material: Aluminum
Average Winding Temperature Rise: 150 degree C
Insulation Class: 220 degree C
Ambient Temperature: 30°C average, 40°C maximum
Efficiency: DOE 2016
Enclosure Rating: Outdoor, NEMA-3RE
Enclosure Finish: ANSI 61 Grey
Sound Level: As per IEEE C57.12.01
Altitude: 1000M
Cooling: AA
Approvals: UL
Seismic: suitable for ground level installation in Laingsburg, MI

Primary Terminations: Close Coupled with Flex Connectors and Flange

Secondary Terminations: Close Coupled with Flex Connectors and Flange

Accessories:

Space Heaters

Transformer Tests:

Ratio Test
Polarity Test
Phase Relation Test
No Load Loss Test
Excitation Current Test
Impedance Voltage Test
Load Loss Test
Applied Potential Test
Induced Potential Test
Resistance Measurement Test
QC Impulse Test HV Only (30kV BIL and above)
Test Reports

Estimated Weight (to be confirmed at design): 8400lbs.
Estimated Dimensions (to be confirmed at design): 102"W x 80"D x 95.5"H

Approval drawings available 3-4 weeks

***** Current Lead times are 26-28 weeks after a confirmed release for manufacturing. Lead times are subject to change and will be confirmed at the time of order release.**

Please Note:

- HPS standard VPE process to be provided per attached.
- HPS to provide dry type VPE transformer per Section 26 11 16.11, part 2.5 Dry Type Transformers only.
- HPS takes exception to explosion resistant, fire resistant.
- HPS standard enclosure to be provided with doors, not panels.
- Optional Test Adders:
 - Insulation Resistance Test: +\$1250 per unit, witness \$2000 per unit
 - Temperature Rise Test: +\$1250 per unit, witness \$2000 per unit
 - ANSI Impulse Test: +\$1250 per unit, witness \$2000 per unit
 - Sound Level Test: +\$600 per unit, witness \$1000 per unit
 - Zero Sequence Impedance Test: +\$1250 per unit, witness \$2000 per unit
 - Partial Discharge Test: +\$1250 per unit, witness \$2000 per unit

- HPS has provided this quote with limited specs. Pricing is valid only for the features and ratings explicitly stated in this quotation. Customer is to advise any additional requirements for HPS to take into consideration.

- Freight Allowed.

- One Year Warranty Included.



May 30, 2023
Attn: Erin Szczegielniak
Fishbeck
Jackson WWTP CWSRF 2022 Improvements
RE: RFI #11 Temporary Generator Connection Point

Allied Mechanical Services, Inc. proposes to provide all labor, supervision, and material for the following scope of work.

- Remove existing generator connection cabinet from the existing location to allow install of exhaust louver opening. Store cable & cabinet for possible use in permanent generator connection point.
- Install camlocks with covers on existing Substation 1 for temporary generator connection point utilizing existing 600 A breaker.

Total Cost.....\$9,811.00

Pricing is firm for 30 days.

Sincerely,

Bob Sweet

Allied Mechanical Services, Inc.
5688 East ML Ave
Kalamazoo, MI 49048
bsweet@alliedmechanical.com
Cell: 269-998-3138

Allied Mechanical Services

Cost summary

Jackson WWTP RFI 11

Date;

5/30/2023

Material	Rate	Hours/Units	Total
			\$0.00
Equipment			
			\$0.00
Total Material & Equip			\$0.00
Labor			
Project Manager	\$108.70	0	\$0.00
Foreman	\$104.35	0	\$0.00
Journeyman	\$100.00	0	\$0.00
Apprentice	\$88.70		\$0.00
Safety Rep	\$108.70		\$0.00
Total Piping Labor			\$0.00
OT Premium			
Foreman 1-1/2	\$41.74	0	\$0.00
Foreman Double	\$83.48	0	\$0.00
Journeyman 1-1/2	\$40.00	0	\$0.00
Journeyman Double	\$80.00	0	\$0.00
Total OT Premium			\$0.00
Sheet Metal Shop Labor			
Foreman	\$104.35	0	\$0.00
Journeyman	\$100.00	0	\$0.00
Foreman OT	\$41.74	0	\$0.00
Journeyman OT	\$40.00	0	\$0.00
Total Sheet Metal Shop			\$0.00
Total Material, Equipment, & Labor			\$0.00
Subcontractors			
Murray Paint			\$0.00
Centennial			\$8,531.00
Grand River			\$0.00
Total Subcontractors			\$8,531.00
Subtotal			\$8,531.00
	15.00%		
Total Value of Extra			\$9,810.65

O 517.543.9900
F 517.543.9911

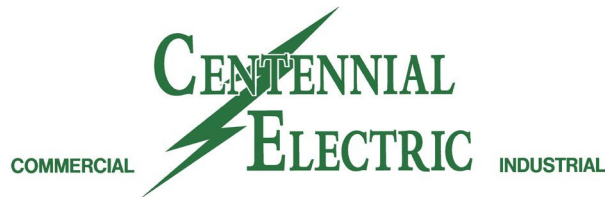

PO BOX 490
POTTERVILLE, MI 48876

5/23/2023

ATT: Bob Sweet
Allied Mechanical Services
5688 E ML Ave.
Kalamazoo, MI 49048

RE: City of Jackson WWTP CWSRF 2022 Improvements- 600A Temporary Generator Connection

Dear Mr. Sweet,

Centennial Electric, LLC, is pleased to quote you for the above mentioned project. We have included the following:

- Demo existing generator connection cabinet to make space available to cut in new mechanical louver
- 800A feeder from generator connection cabinet to existing Sub 3 will be demoed complete
- Install owner provided 600A breaker in Sub 1 for temporary generator connection point
- Install parallel cam locks on the back face of existing Sub 1 using flexible welding cable

Material:	1,671.00
Labor:	5,660.00
Tax:	100.00
OH&P:	1,100.00
Total:	\$ 8,531.00

Please do not hesitate to contact me with any questions.

Sincerely,

A handwritten signature in black ink that reads 'Trevor Strang'.

Trevor Strang
Project Manager
Centennial Electric LLC

Bid Summary Report

Jackson WWTP Estimator: Mike

Job #2043

Job Name: Jackson WWTP

Contractor:

Estimator: Mike

Notes:

Bid Date: 7/14/2022

Summary Description	Material			Labor		
	Extended	%	Adjusted	Extended	%	Adjusted
600A Temp Gen Connect in Ex Sub1	\$1,671.00	100.00%	\$1,671.00	57.10	100.00%	57.10

Top Sheet

Raw Cost	\$7,330.75	Sales per Month	\$0.00
Tax	\$100.26	Return per Month	\$0.00
Raw Cost with Tax	\$7,431.01	Price per Square Foot	\$0.00
Overhead	\$1,099.61	Hours per Square Foot	0.00
Profit	\$0.00	Square Feet	0.00
Total Return Amount	\$1,099.61	Job Months	0.00
Total Return %	12.89%	Hours per Week	0.00
Remaining Labor Hours	0.00	Average Hourly Rate w/ Burden	99.12
Price	\$8,530.62	Workers per Day	0.00
Bond	\$0.00	Total Hours	57.10
Sell Price	\$8,530.62	Markup Sales Tax (Overhead)	No
Adjusted Sell	\$0.00	Markup Sales Tax (Profit)	No
Adjusted Sell Return 0.00%	\$0.00	Use Bond Table	No

Labor

Class Description	Percent of Total	Hours Distributed	Hourly Rate	Burden		Labor Cost
				Rate	Percent	
Journeyman 252	100.00%	57.10	\$99.12	\$0.00	0.00%	\$5,659.75
Foreman 252	0.00%	0.00	\$113.99	\$0.00	0.00%	\$0.00
General Foreman 252	0.00%	0.00	\$123.90	\$0.00	0.00%	\$0.00
Totals	100.00%	57.10	\$99.12	\$0.00	0.00%	\$5,659.75

Bid Summary Report

Jackson WWTP Estimator: Mike

Job #2043

Mark Ups	OVERHEAD				PROFIT
	Total	%	Amount	%	Amount
Materials	\$1,671.00	+ 15.00%	\$1,921.65	+ 0.00%	\$1,921.65
Labor	\$5,659.75	+ 15.00%	\$6,508.71	+ 0.00%	\$6,508.71
Supplier Quotes	\$0.00	+ 15.00%	\$0.00	+ 0.00%	\$0.00
SubContractors	\$0.00	+ 15.00%	\$0.00	+ 0.00%	\$0.00
Direct Job Expense	\$0.00	+ 15.00%	\$0.00	+ 0.00%	\$0.00
Equipment Rental	\$0.00	+ 15.00%	\$0.00	+ 0.00%	\$0.00
Fixtures Quotes	\$0.00	+ 15.00%	\$0.00	+ 0.00%	\$0.00
Totals	\$7,330.75	15.00%	\$8,430.36	0.00%	\$8,430.36

Tax Report	Taxed Amount	Tax Rate %	Tax Amount
Materials	\$1,671.00	6.00%	\$100.26
Labor	\$5,659.75	0.00%	\$0.00
Supplier Quotes	\$0.00	6.00%	\$0.00
SubContractors	\$0.00	6.00%	\$0.00
Direct Job Expense	\$0.00	6.00%	\$0.00
Equipment Rental	\$0.00	6.00%	\$0.00
Fixtures Quotes	\$0.00	6.00%	\$0.00
		Total Tax:	\$100.26

Job Name: Jackson WWTP

Job Number: 2043

Extension Name: 600A Temp Gen Connect in Ex Sub1

Item #	Item Name	Quantity	Book Price	U	Ext Book Price	NECA 1	U	Labor 1 Ext	CCode	% of Extended Price	% of Extended Hours
Label Set: Combined, Combined, Combined, Combined, Combined					\$1,671.00			57.10		100%	100%
CCode: <none>					<u>\$1,671.00</u>			<u>53.50</u>		<u>100%</u>	<u>93.7%</u>
60,263	Demo Ex Gen Connection Cabinet	1.00	\$10.00	E	\$10.00	4.00	E	4.00			
60,264	4/0 CU Welding Cable Jumper 8'	8.00	\$129.00	E	\$1,032.00	1.00	E	8.00			
60,265	Camlock Terminal to Ex Enclosure	8.00	\$63.00	E	\$504.00	1.25	E	10.00			
60,266	Cable Demo	1.00	\$25.00	E	\$25.00	24.00	E	24.00			
60,267	4" GRC Demo	1.00	\$25.00	E	\$25.00	4.00	E	4.00			
60,268	Install 600A Breaker	1.00	\$0.00	X	\$0.00	1.50	E	1.50			
60,271	Generator Procedure	1.00	\$75.00	E	\$75.00	2.00	E	2.00			
CCode: Lugs/Termination/Ground					<u>\$0.00</u>			<u>3.60</u>		<u>0%</u>	<u>6.3%</u>
5,786	600A CIRCUIT TERM	2.00	\$0.00	X	\$0.00	1.80	E	3.60	sl		
					\$1,671.00			57.10			



June 7, 2023
Attn: Erin Szczegielniak
Fishbeck
Jackson WWTP CWSRF 2022 Improvements
RE: RFI #29 Sludge Building Water Infiltration

Allied Mechanical Services, Inc. proposes to provide all labor, supervision, and material for the following scope of work.

- Inject 5 lineal feet of crack on inside wall of sludge building.

Total Cost\$878.00

Pricing is firm for 30 days.

Sincerely,

Bob Sweet

Allied Mechanical Services, Inc.
5688 East ML Ave
Kalamazoo, MI 49048
bsweet@alliedmechanical.com
Cell: 269-998-3138

Allied Mechanical Services

Cost summary

Jackson WWTP RFI 29 5' only

Date;

6/8/2023

Material	Rate	Hours/Units	Total
			\$0.00
Equipment			
Total Material & Equip			\$0.00
Labor			
Project Manager	\$108.70		\$0.00
Foreman	\$104.35	1	\$52.18
Journeyman	\$100.00	0	\$0.00
Apprentice	\$88.70	0	\$0.00
Safety Rep	\$108.70	0	\$0.00
Total Piping Labor			\$52.18
OT Premium			
Foreman 1-1/2	\$41.74	0	\$0.00
Foreman Double	\$83.48	0	\$0.00
Journeyman 1-1/2	\$40.00	0	\$0.00
Journeyman Double	\$80.00	0	\$0.00
Total OT Premium			\$0.00
Sheet Metal Shop Labor			
Foreman	\$108.70	0	\$0.00
Journeyman	\$100.00	0	\$0.00
Foreman OT	\$41.74	0	\$0.00
Journeyman OT	\$40.00	0	\$0.00
Total Sheet Metal Shop			\$0.00
Total Material, Equipment, & Labor			\$52.18
Subcontractors			
Murray Paint			\$0.00
Centennial			\$0.00
Grand River			\$711.00
Total Subcontractors			\$711.00
Subtotal			\$763.18
	15.00%		
Total Value of Extra			\$877.65



Grand River Construction, Inc.

General Contractors • Commercial and Industrial • Concrete Specialist

June 7, 2023

Mr. Bob Sweet
Allied Mechanical Services, Inc.
5688 E ML Avenue A
Kalamazoo, MI 49048

RE: Jackson WWTP CWSRF 2022 Improvements
Change Request – Sludge Bldg. Structural Injection (RFI_29)

Dear Mr. Sweet,

Please see the attached pricing as requested for the scope of work associated with injecting the five (5) lineal feet of wall inside the Sludge Building per the response to RFI_29.

RFI_29 Work Scope:

- Route & clean crack.
- Furnish & install injection ports.
- Furnish & install Sika Fix HH+ in crack.

Firm Lump Sum..... \$711.00

Sincerely,

GRAND RIVER CONSTRUCTION, INC.

Dave Nyhuis
Project Manager & Estimator

REFERENCE: Bulletin 1; RFI_29 DATE: 6/7/2023
 PROJECT: Jackson WWTP CWSRF Improvements Project
 DESCRIPTION: Inject 5 lineal feet of wall inside Sludge Bldg. using Sika Fix HH Plus.

A. Equipment, Materials, and Supplies

Sika Fix HH Plus		147.00	
Ports		15.00	
Small Tools/router		75.00	
	Subtotal	<u>237.00</u>	
	Sales Tax 6%	8.82	
	Overhead 10%	<u>24.58</u>	
	Material Total		270.40

B. Labor:

<u>Trade</u>	<u>Hours</u>	<u>Rate</u>	
Project Foreman	0.00	\$95.00	0.00
Carpenter	0.00	\$62.19	0.00
Laborer	8.00	\$47.84	382.75
Finisher	0.00	\$60.37	0.00
Operator	0.00	\$78.71	0.00
	Subtotal		<u>382.75</u>
	Overhead 15%		<u>57.41</u>
	Labor Total		440.16

C. Subcontractors

	Subtotal	<u>0.00</u>	
	Overhead 10%	<u>0.00</u>	
	Subcontractor Total		<u>0.00</u>
	TOTAL A+B+C		<u>710.57</u>
	TOTAL:		711.00



May 11, 2023
Attn: Erin Szczegielniak
Fishbeck
Jackson WWTP CWSRF 2022 Improvements
RE: RFI #35 Wall Cap Replacement Reinforcement

Allied Mechanical Services, Inc. proposes to provide all labor, supervision, and material for the following scope of work.

- Purchase and install reinforcing steel per section view provided in RFI 35.

Total Cost\$5,384.00

Pricing is firm for 30 days.

Sincerely,

Bob Sweet

Allied Mechanical Services, Inc.
5688 East ML Ave
Kalamazoo, MI 49048
bsweet@alliedmechanical.com
Cell: 269-998-3138

Allied Mechanical Services

Cost summary

Jackson WWTP RFI 35

Date;

5/11/2023

Material	Rate	Hours/Units	Total
			\$0.00
Equipment			
Total Material & Equip			\$0.00

Labor	Rate	Hours/Units	Total
Project Manager	\$108.70	1	\$108.70
Foreman	\$104.35	1	\$104.35
Journeyman	\$100.00	0	\$0.00
Apprentice	\$88.70	0	\$0.00
Safety Rep	\$108.70	0	\$0.00
Total Piping Labor			\$213.05

OT Premium	Rate	Hours/Units	Total
Foreman 1-1/2	\$41.74	0	\$0.00
Foreman Double	\$83.48	0	\$0.00
Journeyman 1-1/2	\$40.00	0	\$0.00
Journeyman Double	\$80.00	0	\$0.00
Total OT Premium			\$0.00

Sheet Metal Shop Labor	Rate	Hours/Units	Total
Foreman	\$108.70	0	\$0.00
Journeyman	\$100.00	0	\$0.00
Foreman OT	\$41.74	0	\$0.00
Journeyman OT	\$40.00	0	\$0.00
Total Sheet Metal Shop			\$0.00

Total Material, Equipment, & Labor \$213.05

Subcontractors	Total
Murray Paint	\$0.00
Centennial	\$0.00
Grand River	\$4,469.00
Total Subcontractors	\$4,469.00
Subtotal	\$4,682.05
Total Value of Extra	15.00% <u>\$5,384.36</u>



Grand River Construction, Inc.

General Contractors • Commercial and Industrial • Concrete Specialist

April 20, 2023

Mr. Bob Sweet
Allied Mechanical Services, Inc.
5688 E ML Avenue A
Kalamazoo, MI 49048

RE: Jackson WWTP CWSRF 2022 Improvements
Change Request – Reinforcing in Clarifier Wall Cap RFI_35

Dear Mr. Sweet,

Please see the attached pricing to furnish & install the reinforcing steel components in the wall cap between primary clarifiers 2 & 3 per the response to RFI_35.

Work Scope:

- Furnish & install #5 dowels using HILTI epoxy adhesive.
- Furnish & install #5 continuous bars.

Firm Lump Sum..... \$4,469.00

Sincerely,

GRAND RIVER CONSTRUCTION, INC.

Dave Nyhuis
Project Manager & Estimator



June 5, 2023
Attn: Erin Szczegielniak
Fishbeck
Jackson WWTP CWSRF 2022 Improvements
RE: RFI #39 & 45 Concrete Rehab Added Scope Rev.5

Allied Mechanical Services, Inc. proposes to provide all labor, supervision, and material for the following scope of work.

- Complete additional concrete rehabilitation scoped as outlined in RFI 45.
Total Cost.....\$38,124.00

- Complete additional concrete rehabilitation scoped as outlined in RFI 39.
Total Cost\$3,014.00

Pricing is firm for 30 days.

Sincerely,

Bob Sweet

Allied Mechanical Services, Inc.
5688 East ML Ave
Kalamazoo, MI 49048
bsweet@alliedmechanical.com
Cell: 269-998-3138

Allied Mechanical Services

Cost summary

Jackson WWTP RFI 45

Date;

6/5/2023

Material	Rate	Hours/Units	Total
			\$0.00
Equipment			
Total Material & Equip			\$0.00
Labor			
Project Manager	\$108.70	1	\$108.70
Foreman	\$104.35	19	\$1,982.65
Journeyman	\$100.00	0	\$0.00
Apprentice	\$88.70		\$0.00
Safety Rep	\$108.70		\$0.00
Total Piping Labor			\$2,091.35
OT Premium			
Foreman 1-1/2	\$41.74	0	\$0.00
Foreman Double	\$83.48	0	\$0.00
Journeyman 1-1/2	\$40.00	0	\$0.00
Journeyman Double	\$80.00	0	\$0.00
Total OT Premium			\$0.00
Sheet Metal Shop Labor			
Foreman	\$104.35	0	\$0.00
Journeyman	\$100.00	0	\$0.00
Foreman OT	\$41.74	0	\$0.00
Journeyman OT	\$40.00	0	\$0.00
Total Sheet Metal Shop			\$0.00
Total Material, Equipment, & Labor			\$2,091.35
Subcontractors			
Murray Paint			\$0.00
Centennial			\$0.00
Grand River			\$31,060.00
Total Subcontractors			\$31,060.00
Subtotal			\$33,151.35
Total Value of Extra			15.00%
			\$38,124.05

Allied Mechanical Services

Cost summary

Jackson WWTP RFI 39

Date;

6/5/2023

Material	Rate	Hours/Units	Total
			\$0.00
Equipment			
			\$0.00
Total Material & Equip			\$0.00
Labor			
Project Manager	\$108.70	0	\$0.00
Foreman	\$104.35	2	\$208.70
Journeyman	\$100.00	0	\$0.00
Apprentice	\$88.70		\$0.00
Safety Rep	\$108.70		\$0.00
Total Piping Labor			\$208.70
OT Premium			
Foreman 1-1/2	\$41.74	0	\$0.00
Foreman Double	\$83.48	0	\$0.00
Journeyman 1-1/2	\$40.00	0	\$0.00
Journeyman Double	\$80.00	0	\$0.00
Total OT Premium			\$0.00
Sheet Metal Shop Labor			
Foreman	\$104.35	0	\$0.00
Journeyman	\$100.00	0	\$0.00
Foreman OT	\$41.74	0	\$0.00
Journeyman OT	\$40.00	0	\$0.00
Total Sheet Metal Shop			\$0.00
Total Material, Equipment, & Labor			\$208.70
Subcontractors			
Murray Paint			\$0.00
Centennial			\$0.00
Grand River			\$2,412.00
Total Subcontractors			\$2,412.00
Subtotal			\$2,620.70
Total Value of Extra			15.00%
			\$3,013.81



Grand River Construction, Inc.

General Contractors • Commercial and Industrial • Concrete Specialist

May 4, 2023

Mr. Bob Sweet
Allied Mechanical Services, Inc.
5688 E ML Avenue A
Kalamazoo, MI 49048

RE: Jackson WWTP CWSRF 2022 Improvements
Change Request – Additional work in Clarifiers 1-6 per RFI's 39 & 45

Dear Mr. Sweet,

Please see the attached pricing as requested for the added scope of work in clarifiers 1-6 per RFI's 39 & 45.

RFI 39 Work Scope: **Bulletin 1 item #6**

- Type 1 extra valve hole: Patch/infill per typical concrete detail. Quantity: 6
- Type 2 metal sleeve (app. 2") extending above slab: Cut flush & leave unfilled. Quantity: 6
- Type 3 metal sleeve (app. 4") extending above slab: Remove sleeve, patch/infill per typical concrete detail. Quantity: 6

Firm Lump Sum..... \$2,412.00

RFI 45 Work Scope: **Bulletin 1 Item #5**

- Add 102 LF of cracks in clarifier walls to receive cleaning & structural injection with Sika Fix HH Plus per key note 3 on S101.
 - Quantity per RFI_45: 138 LF.
 - Bid quantity: 36 LF.
- Add 13 SF of deteriorated concrete to be removed and replaced per the typical concrete detail and key notes 1 on S101 & S102.
 - Quantity per RFI_45: 73 SF.
 - Bid quantity: 86 SF.
 - Although the quantity per RFI_45 resulted in less square footage, there is added costs due to the difficulty of patching the bottom of the deteriorated beams. See numbers 13, 14, 16, 18 & 25 in RFI_45.
- ~~Add 16 LF of routing cracks in deck and sealing with SikaFlex-2C NES caulk.~~
 - ~~Quantity per RFI_45: 16 LF.~~
 - ~~Bid scope included crack routing & sealing of 3 lineal feet per post at 139 posts. Drawing S102 does not call for any crack repairs on the top slab.~~
- Added work scope for RFI_45 will add 21 days to the schedule.

5025 40th Avenue, Hudsonville, MI 49426
Phone: 616-669-5611

www.grandriverconstruction.com
Fax: 616-669-3466



Firm Lump Sum.....~~\$33,440.00~~
\$31,060.00

Sincerely,

GRAND RIVER CONSTRUCTION, INC.

Dave Nyhuis
Project Manager & Estimator

Item 2	\$	41,898.00
Item 3	\$	(1,980.00)
Item 4	\$	(8,858.00)
Item 5	\$	2,380.00
	\$	33,440.00
		\$31,060.00

REFERENCE: RFI_45 DATE: 5/19/2023
 PROJECT: Jackson WWTP CWSRF Improvements Project
 DESCRIPTION: Revised work scope to Primary Clarifiers 1-6 tanks.

A. Equipment, Materials, and Supplies

Sika Products (Grout, bonding agent, Poly. Injection)		4,137.00	
Small Tools		850.00	
Concrete Accessories		685.00	
GRC Trucking		650.00	
	Subtotal	<u>6,322.00</u>	
	Sales Tax 6%	379.32	
	Overhead 10%	<u>670.13</u>	
	Material Total		7,371.45

B. Labor:

<u>Trade</u>	<u>Hours</u>	<u>Rate</u>		
Project Foreman	32.00	\$95.00	3,040.00	
Carpenter	120.00	\$62.19	7,462.37	
Laborer	408.00	\$47.84	19,520.35	
Finisher	0.00	\$60.37	0.00	
Operator	0.00	\$78.71	<u>0.00</u>	
		Subtotal	30,022.72	
		Overhead 15%	<u>4,503.41</u>	
		Labor Total		34,526.13

C. Subcontractors

	Subtotal	<u>0.00</u>	
	Overhead 10%	<u>0.00</u>	
	Subcontractor Total		0.00
	TOTAL A+B+C		<u>41,897.58</u>
	TOTAL ITEM 2:		<u>41,898.00</u>

REFERENCE: RFI_45 DATE: 5/19/2023
 PROJECT: Jackson WWTP CWSRF Improvements Project
 DESCRIPTION: Deduct bid quantity of 36 LF of structural injection per KN3 on S101.

A. Equipment, Materials, and Supplies

Bid Material Deduct -496.00

	Subtotal	-496.00	
	Sales Tax 6%	0.00	
	Overhead 10%	0.00	
	Material Total		-496.00

B. Labor:

<u>Trade</u>	<u>Hours</u>	<u>Rate</u>	
Project Foreman	0.00	\$95.00	0.00
Carpenter	0.00	\$62.19	0.00
Laborer	-31.00	\$47.84	-1,483.16
Finisher	0.00	\$60.37	0.00
Operator	0.00	\$78.71	0.00
		Subtotal	-1,483.16
		Overhead 15%	0.00
		Labor Total	-1,483.16

C. Subcontractors

	Subtotal	0.00	
	Overhead 10%	0.00	
	Subcontractor Total		0.00
		TOTAL A+B+C	-1,979.16
		TOTAL ITEM 3:	-1,980.00

REFERENCE: RFI_45 DATE: 5/19/2023
 PROJECT: Jackson WWTP CWSRF Improvements Project
 DESCRIPTION: Deduct bid quantity of 86 SF of patching per KN1 on S101.

A. Equipment, Materials, and Supplies

Bid Material Deduct -2,207.50

	Subtotal	-2,207.50	
	Sales Tax 6%	0.00	
	Overhead 10%	0.00	
	Material Total		-2,207.50

B. Labor:

<u>Trade</u>	<u>Hours</u>	<u>Rate</u>	
Project Foreman	0.00	\$95.00	0.00
Carpenter	0.00	\$62.19	0.00
Laborer	-139.00	\$47.84	-6,650.32
Finisher	0.00	\$60.37	0.00
Operator	0.00	\$78.71	0.00
		Subtotal	-6,650.32
		Overhead 15%	0.00
		Labor Total	-6,650.32

C. Subcontractors

	Subtotal	0.00	
	Overhead 10%	0.00	
	Subcontractor Total		0.00
		TOTAL A+B+C	-8,857.82
		TOTAL ITEM 4:	-8,858.00

REFERENCE: RFI_45 DATE: 5/19/2023
 PROJECT: Jackson WWTP CWSRF Improvements Project
 DESCRIPTION: Add 16 LF of routing & caulking cracks per detail 3/S104.

A. Equipment, Materials, and Supplies

Material Add 719.88

Subtotal 719.88
 Sales Tax 6% 43.19
 Overhead 10% 76.31
Material Total

839.38

B. Labor:

<u>Trade</u>	<u>Hours</u>	<u>Rate</u>	
Project Foreman	0.00	\$95.00	0.00
Carpenter	0.00	\$62.19	0.00
Laborer	28.00	\$47.84	1,339.63
Finisher	0.00	\$60.37	0.00
Operator	0.00	\$78.71	0.00

Subtotal 1,339.63
 Overhead 15% 200.94
Labor Total

1,540.58

C. Subcontractors

Subtotal 0.00
 Overhead 10% 0.00
Subcontractor Total

0.00

TOTAL A+B+C 2,379.95
TOTAL ITEM 5: 2,380.00



June 7, 2023
Attn: Erin Szczegielniak
Fishbeck
Jackson WWTP CWSRF 2022 Improvements
RE: RFI #42 Exterior Lights Clarifier 1-6 Deck

Allied Mechanical Services, Inc. proposes to provide all labor, supervision, and material for the following scope of work.

- Install (6) exterior lights on clarifier 1-6 deck.

Total Cost\$50,564.00

Pricing is firm for 30 days.

Sincerely,

Bob Sweet

Allied Mechanical Services, Inc.
5688 East ML Ave
Kalamazoo, MI 49048
bsweet@alliedmechanical.com
Cell: 269-998-3138

Allied Mechanical Services

Cost summary

Jackson WWTP RFI 42

Date;

6/7/2023

Material	Rate	Hours/Units	Total
			\$0.00
Equipment			
Total Material & Equip			\$0.00
Labor			
Project Manager	\$108.70	0	\$0.00
Foreman	\$104.35	4	\$417.40
Journeyman	\$100.00	0	\$0.00
Apprentice	\$88.70	0	\$0.00
Safety Rep	\$108.70	0	\$0.00
Total Piping Labor			\$417.40
OT Premium			
Foreman 1-1/2	\$41.74	0	\$0.00
Foreman Double	\$83.48	0	\$0.00
Journeyman 1-1/2	\$40.00	0	\$0.00
Journeyman Double	\$80.00	0	\$0.00
Total OT Premium			\$0.00
Sheet Metal Shop Labor			
Foreman	\$108.70	0	\$0.00
Journeyman	\$100.00	0	\$0.00
Foreman OT	\$41.74	0	\$0.00
Journeyman OT	\$40.00	0	\$0.00
Total Sheet Metal Shop			\$0.00
Total Material, Equipment, & Labor			\$417.40
Subcontractors			
Murray Paint			\$0.00
Centennial			\$43,551.00
Grand River			\$0.00
Total Subcontractors			\$43,551.00
Subtotal			\$43,968.40
Total Value of Extra			15.00%
			\$50,563.66

O 517.543.9900
F 517.543.9911



PO BOX 490
POTTERVILLE, MI 48876

6/7/2023

ATT: Bob Sweet
Allied Mechanical Services
5688 E ML Ave.
Kalamazoo, MI 49048

RE: City of Jackson WWTP CWSRF 2022 Improvements- Clarifier 1-6 Lighting and Receptacles

Dear Mr. Sweet,

Centennial Electric, LLC, is pleased to quote you for the above mentioned project. We have included the following:

- Clarifier lighting and receptacles per Bulletin 1 Item No. 7

Material:	14,079.00
Labor:	11,607.00
Fixture Quotes:	10,644.00
Direct Expenses:	250.00
Tax:	1,484.00
OH&P:	5,487.00
Total:	\$ 43,551.00

Please do not hesitate to contact me with any questions.

Sincerely,

A handwritten signature in black ink that reads 'Trevor Strang'.

Trevor Strang
Project Manager
Centennial Electric LLC

Bid Summary Report

Jackson WWTP Estimator: Mike

Job #2043

Job Name: Jackson WWTP

Contractor:

Estimator: Mike

Notes:

Bid Date: 7/14/2022

Summary Description	Material			Labor		
	Extended	%	Adjusted	Extended	%	Adjusted
Bulletin 1- Item 7	\$14,079.29	100.00%	\$14,079.29	117.10	100.00%	117.10

Top Sheet

Raw Cost	\$36,580.57	Sales per Month	\$0.00
Tax	\$1,483.40	Return per Month	\$0.00
Raw Cost with Tax	\$38,063.97	Price per Square Foot	\$0.00
Overhead	\$5,487.09	Hours per Square Foot	0.00
Profit	\$0.00	Square Feet	0.00
Total Return Amount	\$5,487.09	Job Months	0.00
Total Return %	12.60%	Hours per Week	0.00
Remaining Labor Hours	0.00	Average Hourly Rate w/ Burden	99.12
Price	\$43,551.06	Workers per Day	0.00
Bond	\$0.00	Total Hours	117.10
Sell Price	\$43,551.06	Markup Sales Tax (Overhead)	No
Adjusted Sell	\$0.00	Markup Sales Tax (Profit)	No
Adjusted Sell Return 0.00%	\$0.00	Use Bond Table	No

Labor

Class Description	Percent of Total	Hours Distributed	Hourly Rate	Burden		Labor Cost
				Rate	Percent	
Journeyman 252	100.00%	117.10	\$99.12	\$0.00	0.00%	\$11,607.29
Foreman 252	0.00%	0.00	\$113.99	\$0.00	0.00%	\$0.00
General Foreman 252	0.00%	0.00	\$123.90	\$0.00	0.00%	\$0.00
Totals	100.00%	117.10	\$99.12	\$0.00	0.00%	\$11,607.29

Mark Ups

	OVERHEAD		PROFIT	
	Total	%	Amount	%
Materials	\$14,079.29	+ 15.00%	\$16,191.18	+ 0.00%
			\$16,191.18	

Bid Summary Report

Jackson WWTP Estimator: Mike

Job #2043

Labor	\$11,607.29	+	15.00%	\$13,348.38	+	0.00%	\$13,348.38
Supplier Quotes	\$0.00	+	15.00%	\$0.00	+	0.00%	\$0.00
SubContractors	\$0.00	+	15.00%	\$0.00	+	0.00%	\$0.00
Direct Job Expense	\$250.00	+	15.00%	\$287.50	+	0.00%	\$287.50
Equipment Rental	\$0.00	+	15.00%	\$0.00	+	0.00%	\$0.00
Fixtures Quotes	\$10,644.00	+	15.00%	\$12,240.60	+	0.00%	\$12,240.60
Totals	\$36,580.57		15.00%	\$42,067.66		0.00%	\$42,067.66

Tax Report

	Taxed Amount	Tax Rate %	Tax Amount
Materials	\$14,079.29	6.00%	\$844.76
Labor	\$11,607.29	0.00%	\$0.00
Supplier Quotes	\$0.00	6.00%	\$0.00
SubContractors	\$0.00	6.00%	\$0.00
Direct Job Expense	\$0.00	6.00%	\$0.00
Equipment Rental	\$0.00	6.00%	\$0.00
Fixtures Quotes	\$10,644.00	6.00%	\$638.64
Total Tax:			\$1,483.40

Direct Job Expense

Name	Supplier	Tax (6.0%)	Unit Cost	Mult	Amount
Freight		No	\$250.00	1.00	\$250.00
Totals:					\$250.00

Fixtures Quotes

Name	Supplier	Tax (6.0%)	Unit Cost	Mult	Amount
Bulletin Fixture Quote		Yes	\$10,644.00	1.00	\$10,644.00
Totals:					\$10,644.00

Job Name: Jackson WWTP
 Job Number: 2043
 Extension Name: Bulletin 1- Item 7

Item #	Item Name	Quantity	Book Price	U	Ext Book Price	NECA 1	U	Labor 1 Ext	CCode	% of Extended Price	% of Extended Hours
Label Set: Combined, Combined, Combined, Combined, Combined					<u>\$14,079.29</u>			<u>117.10</u>		<u>100%</u>	<u>100%</u>
CCode: <none>					<u>\$542.00</u>			<u>11.00</u>		<u>3.85%</u>	<u>9.39%</u>
	60,222 3/4" Seal Off GRC/PVC	2.00	\$196.00	E	\$392.00	1.50	E	3.00			
	60,226 Core Drill 3/4"	2.00	\$75.00	E	\$150.00	1.00	E	2.00			
	60,228 3/4 GRC BEND	24.00	\$0.00	X	\$0.00	25.00	C	6.00			
CCode: <undefined>					<u>\$2,760.00</u>			<u>12.00</u>		<u>19.6%</u>	<u>10.25%</u>
	60,276 120V 3P Contactor	1.00	\$450.00	E	\$450.00	3.00	E	3.00			
	60,284 Alum Exp Box 1 1/2 and 3/4	6.00	\$385.00	E	\$2,310.00	1.50	E	9.00			
CCode: Branch Rough					<u>\$6,425.16</u>			<u>40.82</u>		<u>45.64%</u>	<u>34.86%</u>
	1,262 3/4 GRC	50.00	\$615.17	C	\$307.59	6.00	C	3.00	cb		
	2,731 3/4 LOCKNUT	10.00	\$127.96	C	\$12.80	0.12	E	1.20	cb		
	2,769 3/4 BUSH PLASTIC	5.00	\$158.23	C	\$7.91	0.12	E	0.60	cb		
	4,234 3/4 GRC/PVC COATED	140.00	\$1,218.79	C	\$1,706.31	8.00	C	11.20	cb		
	4,532 3/4 GRC/PVC EP FEMALE UNION	11.00	\$142.05	E	\$1,562.55	0.50	E	5.50	cb		
	4,612 3/4 GRC/PVC T BODY	9.00	\$190.40	E	\$1,713.60	1.00	E	9.00	cb		
	5,070 3/4 PVC 80	40.00	\$295.41	C	\$118.16	4.50	C	1.80	cb		
	5,489 1/2 FLEX WP	45.00	\$194.42	C	\$87.49	4.00	C	1.80	cb		
	5,501 1/2 FLEX WP CONN	9.00	\$2,126.91	C	\$191.42	0.15	E	1.35	cb		
	5,549 1/2 FLEX WP 90 CONN	9.00	\$3,474.13	C	\$312.67	0.18	E	1.62	cb		
	15,297 4/S BOX 1-1/2" DEEP	3.00	\$2,694.84	C	\$80.85	30.00	C	0.90	cb		
	15,301 4/S SG MUD RING 5/8"DP	3.00	\$1,720.06	C	\$51.60	15.00	C	0.45	cb		
	15,539 3/4 FS BOX 1 GANG	3.00	\$34.75	E	\$104.25	0.70	E	2.10	cb		
	15,653 HINGED COVER, FS DUPLEX	3.00	\$55.99	E	\$167.97	0.10	E	0.30	cb		
CCode: Feeder Rough					<u>\$1,219.62</u>			<u>31.00</u>		<u>8.66%</u>	<u>26.47%</u>
	60,224 3/4" Link Seal	2.00	\$52.00	E	\$104.00	1.00	E	2.00	cf		
	60,272 Eaton Telescoping Pole Mounting	6.00	\$102.00	E	\$612.00	2.50	E	15.00	cf		
	60,273 C Type	6.00	\$25.00	E	\$150.00	1.50	E	9.00	cf		
	60,274 Stainless Rec Plate w/U bolts	3.00	\$105.00	E	\$315.00	1.00	E	3.00	cf		
	60,275 120v PC	1.00	\$38.62	E	\$38.62	2.00	E	2.00	cf		
CCode: Hangers/Anchors					<u>\$261.23</u>			<u>4.62</u>		<u>1.86%</u>	<u>3.94%</u>

Job Name: Jackson WWTP
 Job Number: 2043
 Extension Name: Bulletin 1- Item 7

Item #	Item Name	Quantity	Book Price	U	Ext Book Price	NECA 1	U	Labor 1 Ext	CCode	% of Extended Price	% of Extended Hours
3,315	1/4-20 X 3/4 RH MACH SCREW	23.75	\$6.28	C	\$1.49	2.75	C	0.65	ch		
3,696	1/4 FLAT STL WASHER	23.75	\$282.75	C	\$67.15	0.70	C	0.17	ch		
3,774	1/4 MACHINE BOLT ANCH	23.75	\$27.49	C	\$6.53	16.00	C	3.80	ch		
3,923	BOX SUPPORTS-CLIP ON	3.00	\$290.32	C	\$8.71	0.00	C	0.00	ch		
4,990	B900 PLASTI-BOND	20.00	\$886.73	C	\$177.35	0.00	C	0.00	ch		
CCode: Straps					\$1,361.39			0.95		9.67%	0.81%
3,073	3/4 GRC 1H STL STP	6.25	\$233.39	C	\$14.59	4.00	C	0.25	cs		
4,846	3/4 GRC/PVC 1H STRAP	17.50	\$30.61	E	\$535.68	4.00	C	0.70	cs		
4,872	3/4 GRC/PVC CLAMP BACK	17.50	\$46.35	E	\$811.13	0.00	C	0.00	cs		
CCode: Trim Devices/Plates					\$207.45			1.35		1.47%	1.15%
14,986	1G SS DUPL RECP PLATE	3.00	\$2.90	E	\$8.70	10.00	C	0.30	dt		
15,118	DPLX 5-20R GFCI IV IND HD	3.00	\$66.25	E	\$198.75	35.00	C	1.05	dt		
CCode: Lugs/Termination/Ground					\$4.45			5.32		0.03%	4.54%
5,736	12 GA TERMINATION	36.00	\$0.00	X	\$0.00	0.14	E	5.04	sl		
5,767	20A WIRE TERMINATION	2.00	\$0.00	X	\$0.00	0.14	E	0.28	sl		
5,837	RED 3M WIRE NUT	36.00	\$12.37	C	\$4.45	0.00	C	0.00	sl		
CCode: Branch Wire					\$1,297.99			10.04		9.22%	8.58%
60,278	12 THHN CU STRANDED	1,674.00	\$775.38	M	\$1,297.99	6.00	M	10.04	wb		
					\$14,079.29			117.10			



Wesco Distribution

3440 DUNCKEL RD.
 LANSING, MI 48911
 517-887-0140

Job: JACKSON WWTP CWSRF 2022 IMPROVMENTS

DATE: 6/7/2023

Attn: TREVOR **BULLETIN # 1**

PAGES: 1 OF 1

Susan Sulski ssulski@wesco.com

\$ 10,644.00

We are pleased to quote the following:

QTY	MFR	CATALOG NUMBER/DESCRIPTION	UNIT PRICE	EXTENDED PRICE
6	RED SKY	RND-45-100-277-4K-H2-CG-GRY-ML-SN25	\$ 440.00	\$ 2,640.00
		* New nomenclature		
		*Delivery - pending		
		PLUS FREIGHT		
6	EATON	V65-H-MHK-RTS-A-C-PM5	\$ 1,334.00	\$ 8,004.00
		*2 - 4 Week lead time		
		** FREIGHT PRE-PAID**		
		EATON SPEC SHEET TO FOLLOW		

Terms: **TAX NOT INCLUDED** PRICING FRIM FOR 30 DAYS

SPARE MATERIALS LIKE LAMPS, DRIVERS & LENS ARE **NOT INCLUDED** UNLESS SPECIFIED IN

Note: THE BOM ABOVE.

NOTE: QUANTITIES ARE ONLY APPROXIMATE. EXACT COUNT AND BILL OF MATERIALS IS TO BE

DETERMINED BY THE BUYER. ALL CLERICAL AND STENOGRAPHICAL ERRORS ARE SUBJECT TO CORRECTION.

ACCEPTANCE OF AN ORDER NOT BASED ON ALL ITEMS QUOTED IS UP TO THE DISCRETION OF WESCO. ACCEPTANCE OF AN

Terms: Unless there are different or additional terms and conditions contained in a master agreement that

modify WESCO's Standard Terms, Buyer agrees that this quote and any resulting purchase order will be

governed by WESCO's Terms & Conditions Dated 01/11/07 available at

[HTTP://WWW.WESCO.COM/TERMS_AND_CONDITIONS_OF_SALE.PDF](http://www.wesco.com/terms_and_conditions_of_sale.pdf)

Which Terms are incorporated herein by reference and made part hereof. Please

contact the Seller identified on this Quote if you require a printed copy.

Susan Sulski

QUOTATIONS



ROUND SERIES

A COMPACT, LIGHTWEIGHT LED FIXTURE THAT PACKS A POWERFUL PUNCH. THIS INDUSTRY FAVORITE HAS SEVEN MOUNTING OPTIONS AND PRODUCES 150 LUMENS PER WATT. BEST UTILIZED IN HARSH AND HAZARDOUS ENVIRONMENTS FOR MARINE, POWER, AND CHEMICAL INDUSTRIES.

PICTURED WITH
25° STANCHION MOUNT



CERTIFICATIONS AND RATINGS

CLASS I DIVISION 2, GROUPS A,B,C,D
CLASS II DIVISION 1, GROUPS E,F,G
CLASS II DIVISION 2, GROUPS F,G
CLASS III DIVISION 1
CSA C22.2 No. 137-M1981; 25-1966
CSA C22.2 No. 250.0-08; 250.13
UL 844 HAZARDOUS LOCATION
UL 1598A MARINE VESSELS
UL 1598 WET LOCATIONS
UL 8750 LED SAFETY



DIMENSIONS

A 10.3IN/ 262MM
B 6.1IN/ 155MM

WEIGHT

8.8LB / 4.0KG

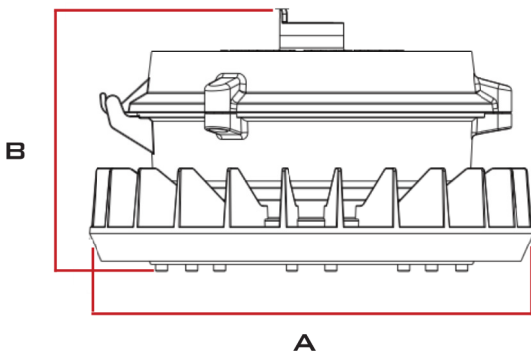

SPECIFICATIONS

VOLTAGE/FREQUENCY	AC 120-277V 50/60HZ AC 347-480V 50/60HZ*
POWER FACTOR	≥95% @ 120V
THD	<20%
SURGE PROTECTION	4KVA
AMBIENT TEMPERATURE	-40°F TO 131°F (-40°C TO 55°C)
T-CODE RATINGS	CLASS I DIVISION 2 - T4A CLASS II DIVISION 1 - T5 CLASS II DIVISION 2 - T5
CONSTRUCTION	DIE-CAST ALUMINUM
LENS MATERIAL	TEMPERED GLASS
HARDWARE	MARINE GRADE STAINLESS STEEL
FINISH	THERMOSET POWDERCOAT
CONNECTION	3/4" NPT
POWER	40W* 45W 60W* 65W
LUMEN OUTPUT (LM)	6,150, 6,750, 10,050, 10150
BEAM ANGLE	110°
COLOR RENDERING INDEX	RA>70
L70	>150,000 HOURS @ 55°C
WARRANTY	LEDS: 10 YEARS DRIVER: 7 YEARS

EXAMPLE: RND-45-120-277-4K-CG-GRY-SN25

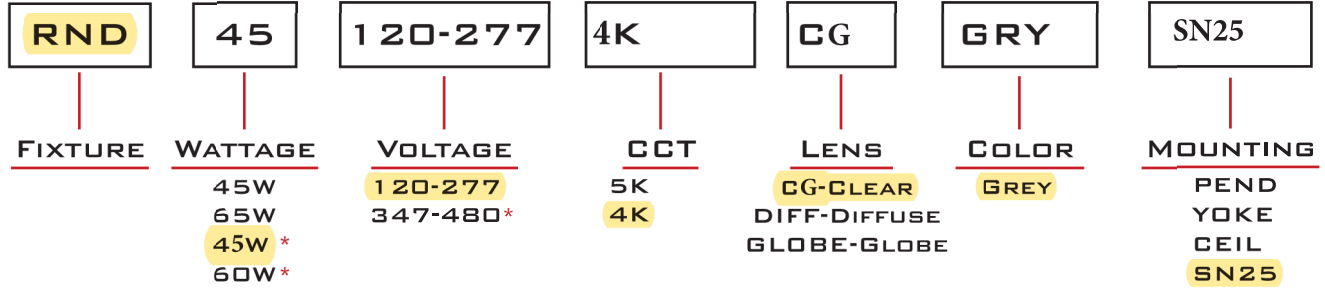

MOUNTING OPTIONS

- PEND - 3/4" NPT PENDANT
- YOKE - 304 STAINLESS YOKE BRACKET
- CEIL - JUNCTION BOX - 3/4" NPT++
- SN25 - STANCHION 25° - 1.5" NPT++
- SN90 - STANCHION 90° - 1.5" NPT++
- WL25 - WALL MOUNT 25° - 3/4" NPT++
- WL90 - WALL MOUNT 90° - 3/4" NPT++

ACCESSORIES

- SFCB: SAFETY CABLE KIT
- WG: FLAT LENS WIRE GUARD
- WGG: GLOBE LENS WIRE GUARD
- SP1: 10KA SURGE PROTECTOR

* 347V ONLY AVAILABLE IN 40W AND 60W/ 40W AND 60W ONLY AVAILABLE IN 347V

++ MOUNTING ADAPTOR (ADPT) WILL BE SUPPLIED WITH ALL MOUNTING OPTIONS EXCEPT PENDANT AND YOKE

PHOTOMETRICS

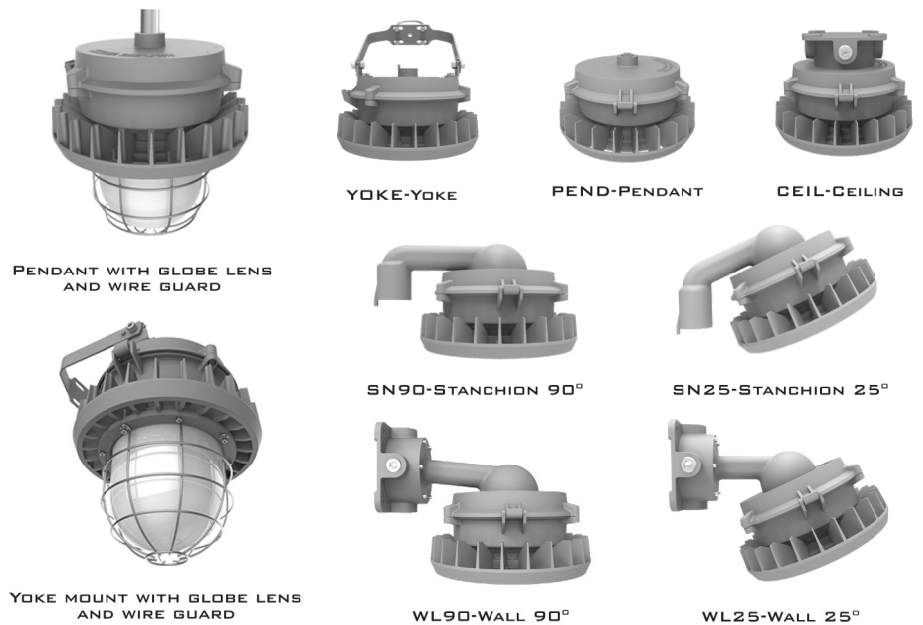
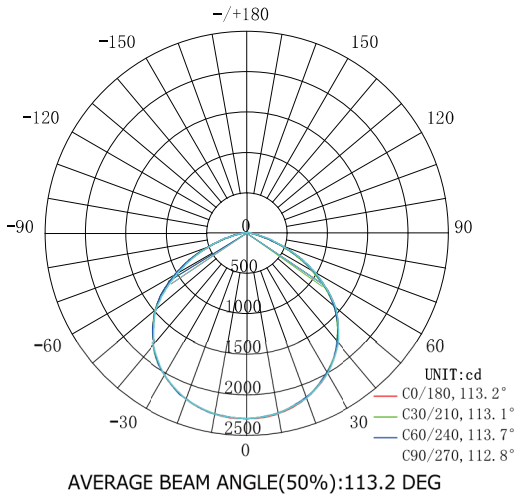

V-Spring telescoping safety light pole

V65-H-MHK-RTS-A-C-PM5

UL Listed
CSA Certified
cULus Listed for Cl. I, Div. 2 &
Cl. II, Div. 2 when used with
Champ luminaires

Dusttight
NEMA 4; IP66

6L

Applications:

- For luminaires installed on industrial walkways, platforms, stairways and conveyors where OSHA/HSE regulations require fall prevention equipment
- Hard to reach or dangerous areas where safety is a big concern
- Hazardous and harsh environments subject to corrosive agents, vibration and extreme temperatures

Certifications and compliances:

- UL844 – Luminaires for use in Hazardous (Classified) Locations, 13th Edition
 - Class I, Division 2, Groups A, B, C, D;
 - Class II, Division 2, Groups F, G
- UL1598 – UL Standard for Safety for Luminaires, 3rd Edition
- CAN/CSA C22.2 No. 137-M1987 – Electric Luminaires for use in Hazardous Locations
- CAN/CSA C22.2 No. 250-08 – Canadian National Standard for Luminaires, 3rd Edition
- cULus Listed for Class I, Division 2, Class II, Division 2 when used with Champ® luminaires

Environmental ratings:

- Dusttight
- NEMA 4, IP66
- Wind rated to 230 mph per AASHTO standards

Vibration:

- DNV No. 2.4: 2006
- IEC 60068-2-6: 2007

Product specifications:

Construction:

- Telescoping
- Factory sealed and pre-wired

Installed height:

- Adjustable raised height

Standard materials:

Light pole options:

- Structural steel – A36-500
- Hot dip galvanized – ASTM 123
- Aluminum – T6061
- Stainless steel – 316 grade

Compression spring:

- Stainless steel

Hardware:

- Xylan 1400 coated for corrosion protection

Cable:

- 12/3 AWG UL/CSA Listed
- 600V, -40°C to 105°C
- Sun- and oil-resistant, FT1, FT2
- ROHS II reach

Weather cover:

- 60 Duro high UV-resistant EPDM

Weights:

Handrail stanchion and wall models:

- Structural steel – 42 lbs.
- Aluminum – 23 lbs.

Base/structural model:

- Structural steel – 70 lbs.
- Aluminum – 34 lbs.

Maximum luminaire weight:

- 50 lbs. (recommended weight for one person operation)

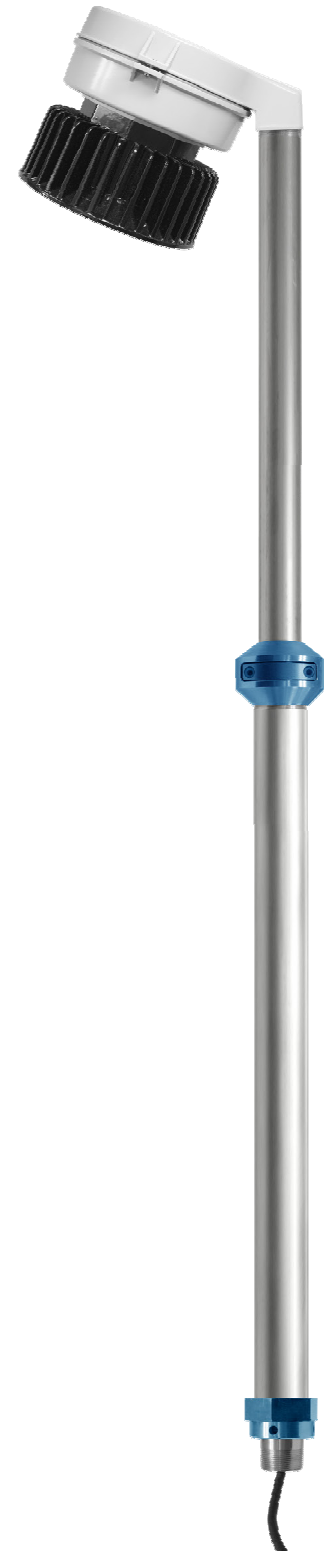

6L

V-Spring telescoping safety light pole

UL Listed
 CSA Certified
 cULus Listed for Cl. I, Div. 2 &
 Cl. II, Div. 2 when used with
 Champ luminaires

Dusttight
 NEMA 4; IP66

6L

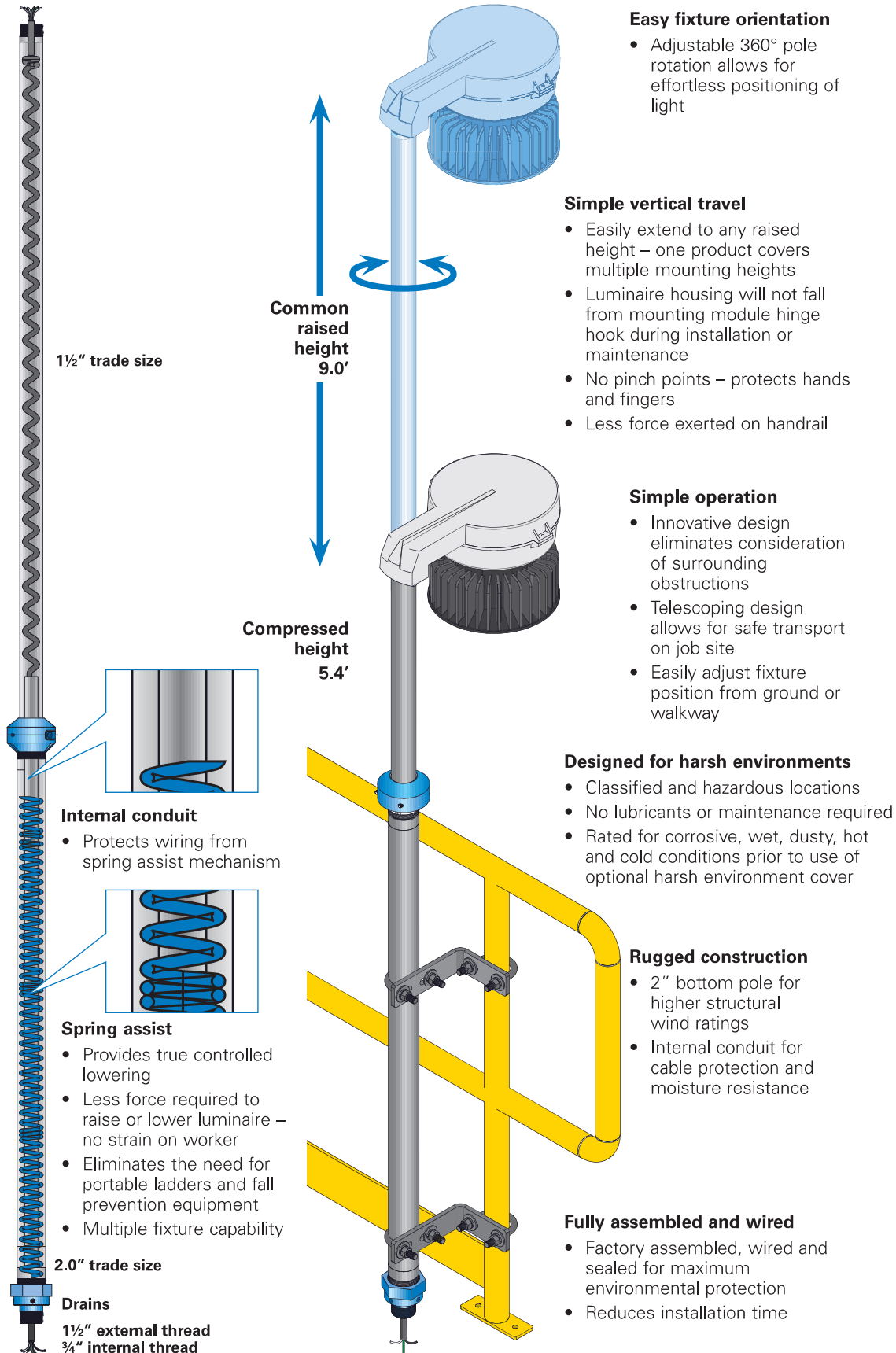

6L

V-Spring telescoping safety light pole

UL Listed
 CSA Certified
 cULus Listed for Cl. I, Div. 2 &
 Cl. II, Div. 2 when used with
 Champ luminaires

Dusttight
 NEMA 4; IP66

6L

Ordering information:

Part number example
V65H-G-JM5-T57

V65 H - G

Series

V65	V-Spring telescoping safety light pole
------------	----------------------------------------

Mounting

B	Base
W	Wall
H	Handrail stanchion

Stanchion mounting kits must be ordered separately.
 See table below for options.

Handrail mounting kits

MHK-RTG	Tubular rail, galvanized
MHK-RTS	Tubular rail, stainless
MHK-RAG	Angled rail, galvanized
MHK-RAS	Angled rail, stainless
MHK-RIG	Incline rail, galvanized
MHK-RIS	Incline rail, stainless

Material

G	Galvanized steel
A	Aluminum
S	316 stainless steel

Harsh environment cover

BLANK	No cover
C	Installed cover for locking collar

Labor savings options

Minimum order quantity: 10 pieces

- JM5 - LTEE2

Lighting tee[Ⓐ]

LTEE2	Lighting tee with 3/4" through feed hubs and 1 1/2" vertical hub, Feraloy iron
LTEE2 SA	Lighting tee with 3/4" through feed hubs and 1 1/2" vertical hub, copper-free aluminum
LTEE3	Lighting tee with 1" through feed hubs and 1 1/2" vertical hub, Feraloy iron
LTEE3 SA	Lighting tee with 1" through feed hubs and 1 1/2" vertical hub, copper-free aluminum

Top hat[Ⓑ]

JM5	25° angled top hat
PM5	Straight top hat



6L

[Ⓐ]Contact factory for additional labor saving options.

[Ⓑ]For Champ luminaires only.

V-Spring telescoping safety light pole

UL Listed
 CSA Certified
 cULus Listed for Cl. I, Div. 2 &
 Cl. II, Div. 2 when used with
 Champ luminaires

Dusttight
 NEMA 4; IP66

6L

Accessories (ordered separately):

Description	Cat. #
Luminaire mounts:	
• 2 ft. (610mm) fluorescent clamp-on.....	LMB-FR240-PC
• 4 ft. (1200mm) fluorescent clamp-on.....	LMB-FR440-PC
• 3 ft. (920mm) fluorescent clamp-on, cross arm.....	LMB-FRT40-PC
• Multi-purpose bolt-on, vertical.....	LMB-WP40-PC
• Multi-purpose bolt-on, horizontal.....	LMB-MP40-PC
• Floodlight bolt-on.....	LMB-FL40-PC
• Junction box plate.....	JBP-G
Champ only luminaire mounts – aluminum:	
• 25° angled top hat.....	JM5
• Straight top hat.....	PM5
Harsh environment cover:	
• Harsh environment cover for locking collar.....	EC65

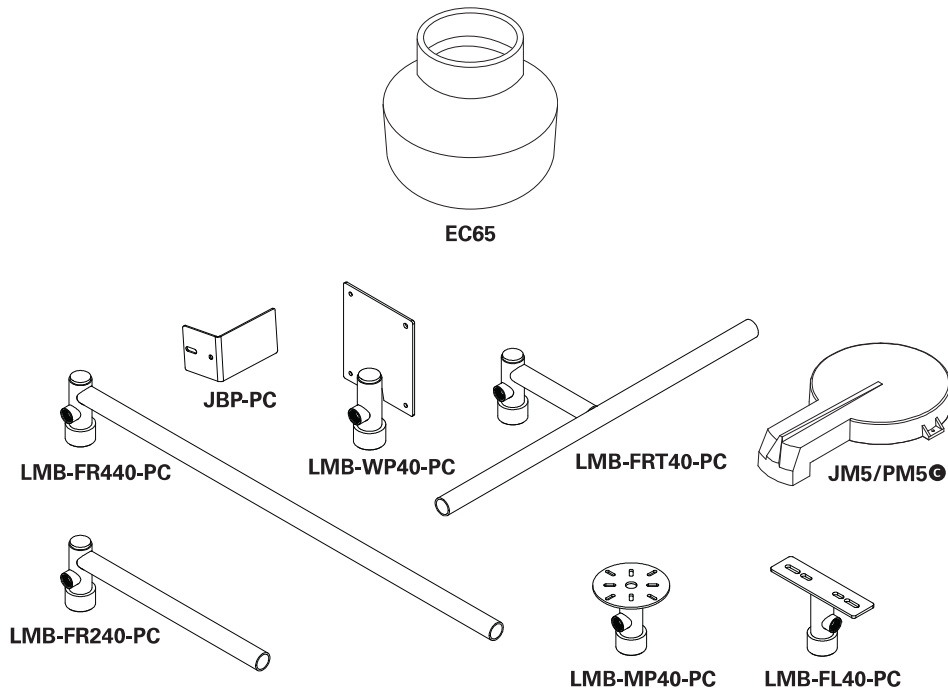

Contact factory for aluminum or stainless options.

Ⓢ For Champ luminaires only.

6L

V-Spring telescoping safety light pole

UL Listed
 CSA Certified
 cULus Listed for Cl. I, Div. 2 &
 Cl. II, Div. 2 when used with
 Champ luminaires

Dusttight
 NEMA 4; IP66

6L

Installation options:

Inclined rail mount

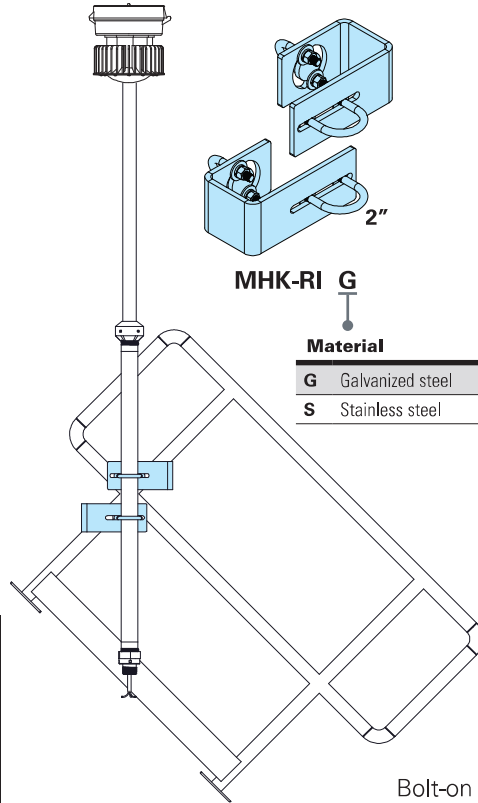

Universal rail mount – tubular rail

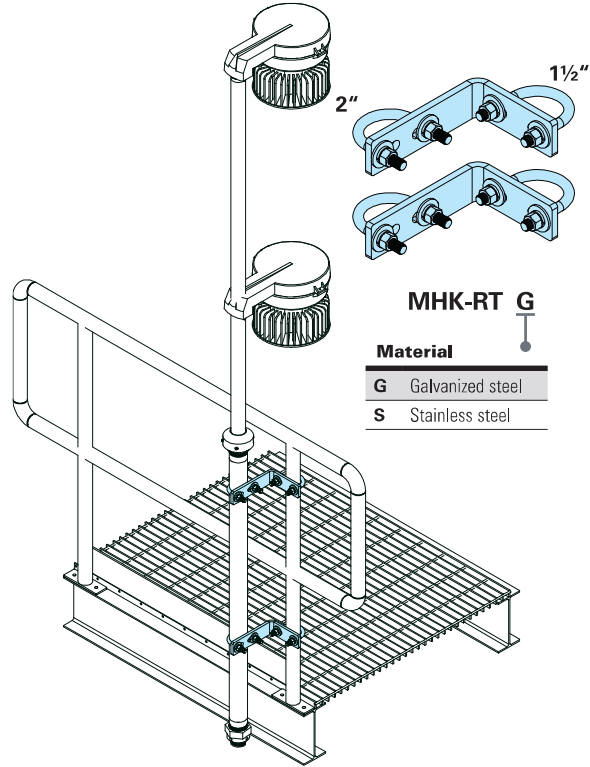

Bolt-on (weld-less) brackets provided as a complete kit

Universal rail mount – angular

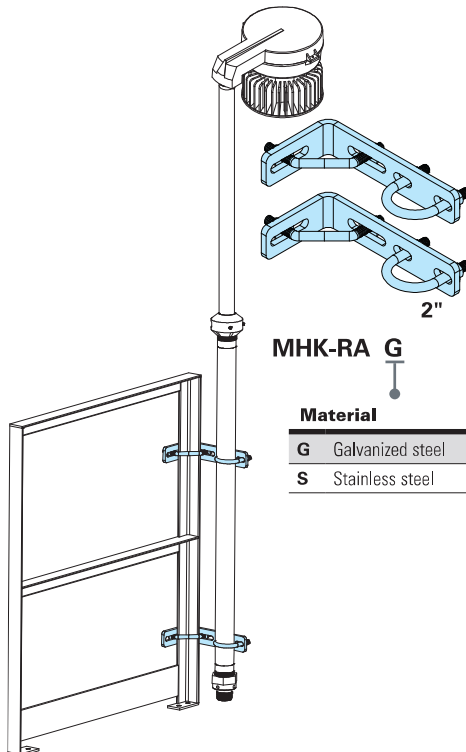

6L

V-Spring telescoping safety light pole

UL Listed
CSA Certified
cULus Listed for Cl. I, Div. 2 &
Cl. II, Div. 2 when used with
Champ luminaires

Dusttight
NEMA 4; IP66

6L

Installation options (continued):

Base mount

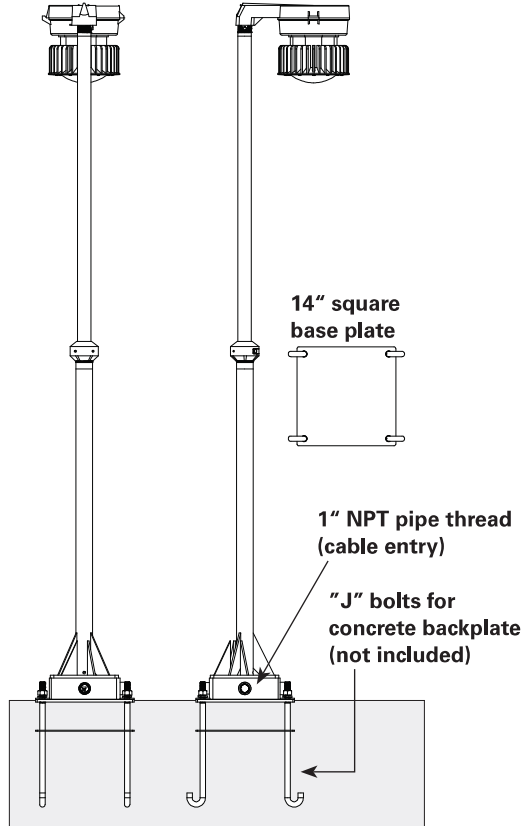

Column/wall mount

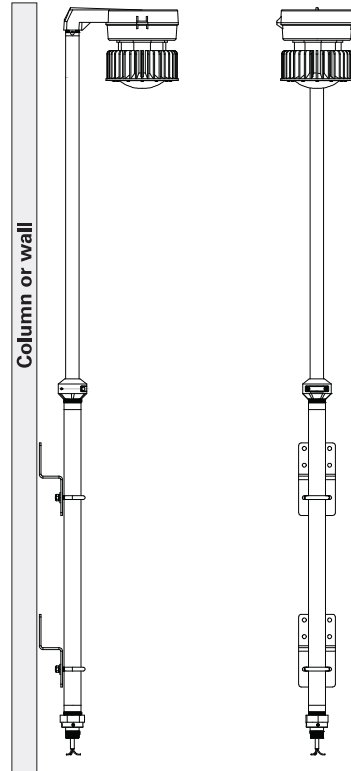

NOTE:

All mounting hardware for base and wall are included with pole.

Wall mount bracket included (MHK-WG).

6L



June 5, 2023
Attn: Erin Szczegielniak
Fishbeck
Jackson WWTP CWSRF 2022 Improvements
RE: RFI #50 Substation 4 Equipment Pad

Allied Mechanical Services, Inc. proposes to provide all labor, supervision, and material for the following scope of work.

- Additional excavation required for new pad location.

Total Cost\$2,180.00

Pricing is firm for 30 days.

Sincerely,

Bob Sweet

Allied Mechanical Services, Inc.
5688 East ML Ave
Kalamazoo, MI 49048
bsweet@alliedmechanical.com
Cell: 269-998-3138

Allied Mechanical Services

Cost summary

Jackson WWTP RFI 50

Date;

6/5/2023

Material	Rate	Hours/Units	Total
			\$0.00
Equipment			
Total Material & Equip			\$0.00

Labor			
Project Manager	\$108.70	0	\$0.00
Foreman	\$104.35	2	\$208.70
Journeyman	\$100.00	0	\$0.00
Apprentice	\$88.70	0	\$0.00
Safety Rep	\$108.70	0	\$0.00
Total Piping Labor			\$208.70

OT Premium			
Foreman 1-1/2	\$41.74	0	\$0.00
Foreman Double	\$83.48	0	\$0.00
Journeyman 1-1/2	\$40.00	0	\$0.00
Journeyman Double	\$80.00	0	\$0.00
Total OT Premium			\$0.00

Sheet Metal Shop Labor			
Foreman	\$108.70	0	\$0.00
Journeyman	\$100.00	0	\$0.00
Foreman OT	\$41.74	0	\$0.00
Journeyman OT	\$40.00	0	\$0.00
Total Sheet Metal Shop			\$0.00

Total Material, Equipment, & Labor \$208.70

Subcontractors		
Murray Paint		\$0.00
Centennial		\$0.00
Grand River		\$1,687.00
Total Subcontractors		\$1,687.00
Subtotal		\$1,895.70
Total Value of Extra	15.00%	<u>\$2,180.06</u>



Grand River Construction, Inc.

General Contractors • Commercial and Industrial • Concrete Specialist

June 1, 2023

Mr. Bob Sweet
Allied Mechanical Services, Inc.
5688 E ML Avenue A
Kalamazoo, MI 49048

RE: Jackson WWTP CWSRF 2022 Improvements
Change Request – Substation 4 Excavation Changes (RFI_50)

Dear Mr. Sweet,

Please see the attached pricing as requested for the added excavation scope of work at the Substation 4 pad per the response to RFI_50.

RFI 50 Work Scope:

- Adjust pad location, grade for positive drainage using existing fill onsite.

Firm Lump Sum..... \$1,687.00

Sincerely,

GRAND RIVER CONSTRUCTION, INC.

Dave Nyhuis
Project Manager & Estimator

REFERENCE: RFI_50 DATE: 6/5/2023
 PROJECT: Jackson WWTP CWSRF Improvements Project
 DESCRIPTION: Adjust pad location & grade for positive drainage per RFI_50.

A. Equipment, Materials, and Supplies

Added Reinforcing Steel		0.00	
Added Formwork		0.00	
Added Concrete		0.00	
Kobelco SK170 Excavator		825.00	
	Subtotal	<u>825.00</u>	
	Sales Tax 6%	49.50	
	Overhead 10%	<u>87.45</u>	
	Material Total		961.95

B. Labor:

<u>Trade</u>	<u>Hours</u>	<u>Rate</u>	
Project Foreman	0.00	\$95.00	0.00
Carpenter	0.00	\$62.19	0.00
Laborer	0.00	\$47.84	0.00
Finisher	0.00	\$60.37	0.00
Operator	8.00	\$78.71	629.68
	Subtotal		<u>629.68</u>
	Overhead 15%		<u>94.45</u>
	Labor Total		724.14

C. Subcontractors

Subtotal	<u>0.00</u>
Overhead 10%	<u>0.00</u>
Subcontractor Total	<u>0.00</u>
TOTAL A+B+C	<u>1,686.09</u>
TOTAL:	<u>1,687.00</u>



May 30, 2023
Attn: Erin Szczegielniak
Fishbeck
Jackson WWTP CWSRF 2022 Improvements
RE: Permanent Generator Connection Point in New Sub 1

Allied Mechanical Services, Inc. proposes to provide all labor, supervision, and material for the following scope of work.

- Eaton to relocate kirk key 1600A breaker to allow for permanent generator connection point.

Total Cost.....\$968.00

Pricing is firm for 30 days.

Sincerely,

Bob Sweet

Allied Mechanical Services, Inc.
5688 East ML Ave
Kalamazoo, MI 49048
bsweet@alliedmechanical.com
Cell: 269-998-3138

Allied Mechanical Services

Cost summary

Jackson WWTP Kirk Key Relocation

Date;

5/30/2023

Material	Rate	Hours/Units	Total
			\$0.00
Equipment			
Total Material & Equip			\$0.00
Labor			
Project Manager	\$108.70	0	\$0.00
Foreman	\$104.35	0	\$0.00
Journeyman	\$100.00	0	\$0.00
Apprentice	\$88.70		\$0.00
Safety Rep	\$108.70		\$0.00
Total Piping Labor			\$0.00
OT Premium			
Foreman 1-1/2	\$41.74	0	\$0.00
Foreman Double	\$83.48	0	\$0.00
Journeyman 1-1/2	\$40.00	0	\$0.00
Journeyman Double	\$80.00	0	\$0.00
Total OT Premium			\$0.00
Sheet Metal Shop Labor			
Foreman	\$104.35	0	\$0.00
Journeyman	\$100.00	0	\$0.00
Foreman OT	\$41.74	0	\$0.00
Journeyman OT	\$40.00	0	\$0.00
Total Sheet Metal Shop			\$0.00
Total Material, Equipment, & Labor			\$0.00
Subcontractors			
Murray Paint			\$0.00
Centennial			\$968.00
Grand River			\$0.00
Total Subcontractors			\$968.00
Subtotal			\$968.00
Total Value of Extra	0.00%		\$968.00

O 517.543.9900
F 517.543.9911

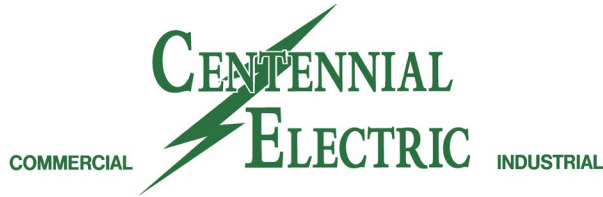

PO BOX 490
POTTERVILLE, MI 48876

5/25/2023

ATT: Bob Sweet
Allied Mechanical Services
5688 E ML Ave.
Kalamazoo, MI 49048

RE: City of Jackson WWTP CWSRF 2022 Improvements- Kirk Key Move in Sub 1 for
Generator Connection Point

Dear Mr. Sweet,

Centennial Electric, LLC, is pleased to quote you for the above mentioned project. We have included the following:

- Eaton factory will move the generator connection kirk key from current 800AF/400AT breaker to previous spare 1600AF/1200AT
- 800AF/400AT breaker will become a spare

Supplier Quotes:	800.00
Tax:	48.00
OH&P:	120.00
Total:	\$ 968.00

Please do not hesitate to contact me with any questions.

Sincerely,

Trevor Strang
Project Manager
Centennial Electric LLC



June 7, 2023
Attn: Erin Szczegielniak
Fishbeck
Jackson WWTP CWSRF 2022 Improvements
RE: RFI #27 Scum Line from Clarifier 7-12

Allied Mechanical Services, Inc. proposes to provide all labor, supervision, and material for the following scope of work.

- Plug the end of scum pipe with concrete in wet well.
- Weld steel plate over end of scum pipe at clarifiers 7-12.

Total Cost\$1,692.00

Pricing is firm for 30 days.

Sincerely,

Bob Sweet

Allied Mechanical Services, Inc.
5688 East ML Ave
Kalamazoo, MI 49048
bsweet@alliedmechanical.com
Cell: 269-998-3138

Allied Mechanical Services

Cost summary

Jackson WWTP RFI 27

Date;

6/7/2023

Material	Rate	Hours/Units	Total
			\$40.00
Equipment			
Total Material & Equip			\$40.00
Labor			
Project Manager	\$108.70		\$0.00
Foreman	\$104.35	4	\$417.40
Journeyman	\$100.00	4	\$400.00
Apprentice	\$88.70	0	\$0.00
Safety Rep	\$108.70	0	\$0.00
Total Piping Labor			\$817.40
OT Premium			
Foreman 1-1/2	\$41.74	0	\$0.00
Foreman Double	\$83.48	0	\$0.00
Journeyman 1-1/2	\$40.00	0	\$0.00
Journeyman Double	\$80.00	0	\$0.00
Total OT Premium			\$0.00
Sheet Metal Shop Labor			
Foreman	\$108.70	0	\$0.00
Journeyman	\$100.00	0	\$0.00
Foreman OT	\$41.74	0	\$0.00
Journeyman OT	\$40.00	0	\$0.00
Total Sheet Metal Shop			\$0.00
Total Material, Equipment, & Labor			\$857.40
Subcontractors			
Murray Paint			\$0.00
Centennial			\$0.00
Grand River			\$614.00
Total Subcontractors			\$614.00
Subtotal			\$1,471.40
	15.00%		
Total Value of Extra			\$1,692.11



Grand River Construction, Inc.

General Contractors • Commercial and Industrial • Concrete Specialist

June 2, 2023

Mr. Bob Sweet
Allied Mechanical Services, Inc.
5688 E ML Avenue A
Kalamazoo, MI 49048

RE: Jackson WWTP CWSRF 2022 Improvements
Change Request – Plug Clarifiers 7-12 Scum Line (RFI_27)

Dear Mr. Sweet,

Please see the attached pricing as requested for the scope of work associated with plugging the scum line at Clarifiers 7-12 per the response to RFI_27.

RFI_27 Work Scope:

- Plug scum pipe using concrete.
- Welding of steel plate after concrete plug is to be performed by others.

Firm Lump Sum..... \$614.00

Sincerely,

GRAND RIVER CONSTRUCTION, INC.

Dave Nyhuis
Project Manager & Estimator

REFERENCE: RFI_27 DATE: 6/5/2023
 PROJECT: Jackson WWTP CWSRF Improvements Project
 DESCRIPTION: Plug the scum pipe from Primary Clarifier Tanks 7-12 using concrete. Welding of steel plate after concrete plug to be performed by others.

A. Equipment, Materials, and Supplies

Concrete		150.00	
	Subtotal	<u>150.00</u>	
	Sales Tax 6%	9.00	
	Overhead 10%	<u>15.90</u>	
	Material Total		174.90

B. Labor:

<u>Trade</u>	<u>Hours</u>	<u>Rate</u>	
Project Foreman	2.00	\$95.00	190.00
Carpenter	0.00	\$62.19	0.00
Laborer	4.00	\$47.84	191.38
Finisher	0.00	\$60.37	0.00
Operator	0.00	\$78.71	0.00
	Subtotal		<u>381.38</u>
	Overhead 15%		<u>57.21</u>
	Labor Total		438.58

C. Subcontractors

	Subtotal	<u>0.00</u>	
	Overhead 10%	<u>0.00</u>	
	Subcontractor Total		<u>0.00</u>
	TOTAL A+B+C		<u>613.48</u>
	TOTAL:		614.00



June 8, 2023
Attn: Erin Szczegielniak
Fishbeck
Jackson WWTP CWSRF 2022 Improvements
RE: Weir and Baffles

Allied Mechanical Services, Inc. proposes to provide all labor, supervision, and material for the following scope of work.

- Increase Clarifier 13 & Clarifier 1-6 weirs and baffles size as required to maintain design water levels.

Total Cost.....\$25,047.00

Pricing is firm for 30 days.

Sincerely,

Bob Sweet

Allied Mechanical Services, Inc.
5688 East ML Ave
Kalamazoo, MI 49048
bsweet@alliedmechanical.com
Cell: 269-998-3138

Allied Mechanical Services

Cost summary

Jackson WWTP Weirs & Baffles

Date;

6/8/2023

Material	Rate	Hours/Units	Total
			\$21,780.00
Equipment			
Total Material & Equip			\$21,780.00

Labor	Rate	Hours/Units	Total
Project Manager	\$108.70	0	\$0.00
Foreman	\$104.35	0	\$0.00
Journeyman	\$100.00	0	\$0.00
Apprentice	\$88.70	0	\$0.00
Safety Rep	\$108.70	0	\$0.00
Total Piping Labor			\$0.00

OT Premium	Rate	Hours/Units	Total
Foreman 1-1/2	\$41.74	0	\$0.00
Foreman Double	\$83.48	0	\$0.00
Journeyman 1-1/2	\$40.00	0	\$0.00
Journeyman Double	\$80.00	0	\$0.00
Total OT Premium			\$0.00

Sheet Metal Shop Labor	Rate	Hours/Units	Total
Foreman	\$108.70	0	\$0.00
Journeyman	\$100.00	0	\$0.00
Foreman OT	\$41.74	0	\$0.00
Journeyman OT	\$40.00	0	\$0.00
Total Sheet Metal Shop			\$0.00

Total Material, Equipment, & Labor \$21,780.00

Subcontractors	Total
Murray Paint	\$0.00
Centennial	\$0.00
Grand River	\$0.00
Total Subcontractors	\$0.00

Subtotal \$21,780.00

Total Value of Extra 15.00% \$25,047.00

From: [Bob Sweet](#)
To: "[Szczegielniak, Erin](#)"
Subject: Jackson WWTP Weirs & Baffles Increased Cost.
Date: Tuesday, June 6, 2023 3:50:00 PM
Attachments: [image002.png](#)
[image007.png](#)

Hi Erin,

See below .



Bob Sweet
Project Manager

Mobile: 269.998.3138

ALLIED MECHANICAL SERVICES



From: Chris Truskowski <chris@nefco.us>
Sent: Tuesday, June 6, 2023 3:14 PM
To: Bob Sweet <bsweet@alliedmechanical.com>; Dieter Wolf <Dieter@nefco.us>
Subject: Re: NEFCO Submittal - Jackson, MI WWTP

Bob,

The baffle extending past the scum baffle brackets its usually determined by the engineer. It is not necessary on a circular clarifier but on clarifiers 1-6 beign a straight wall that is a standard thing for scum baffles. Here is a breakdown of those increases. The biggest cost increase is switching from those angle brackets to the gusseted scum baffle brackets.

FRP W&SB for Six (6) 15' Wide Primary Clarifiers: +\$4,666.00

Increased height to scum baffle panels
change to brackets to accommodate increased scum baffle size.

FRP Influent Baffles for Six (6) 15' Wide Primary Clarifiers (No price change on this scope)

FRP W&SB for One (1) 80' Primary Clarifier No. 13: +\$17,114.00

Increased weir height

weir support angle clips to accommodate weir being more than 8" above weir wall
increased scum baffle height
upgraded scum baffle brackets to accommodate bigger scum baffle panels

Best Regards,



Chris Truskowski
Sales Manager
Chris@nefco.us
561-775-9303 Extension 205
www.nefco.us



June 26, 2023
Attn: Erin Szczegielniak
Fishbeck
Jackson WWTP CWSRF 2022 Improvements
RE: RFI #31 Scum Wall Sleeves Clarifiers 1-6

Allied Mechanical Services, Inc. proposes to provide all labor, supervision, and material for the following scope of work.

- Blast & Paint scum wall sleeves per direction provided in RFI 31.

Total Cost\$7,777.00

Pricing is firm for 30 days.

Sincerely,

Bob Sweet

Allied Mechanical Services, Inc.
5688 East ML Ave
Kalamazoo, MI 49048
bsweet@alliedmechanical.com
Cell: 269-998-3138

Allied Mechanical Services

Cost summary

Jackson WWTP RFI 31

Date;

6/26/2023

Material	Rate	Hours/Units	Total
			\$0.00
Equipment			
Total Material & Equip			\$0.00
Labor			
Project Manager	\$108.70		\$0.00
Foreman	\$104.35	1	\$104.35
Journeyman	\$100.00	0	\$0.00
Apprentice	\$88.70	0	\$0.00
Safety Rep	\$108.70	0	\$0.00
Total Piping Labor			\$104.35
OT Premium			
Foreman 1-1/2	\$41.74	0	\$0.00
Foreman Double	\$83.48	0	\$0.00
Journeyman 1-1/2	\$40.00	0	\$0.00
Journeyman Double	\$80.00	0	\$0.00
Total OT Premium			\$0.00
Sheet Metal Shop Labor			
Foreman	\$108.70	0	\$0.00
Journeyman	\$100.00	0	\$0.00
Foreman OT	\$41.74	0	\$0.00
Journeyman OT	\$40.00	0	\$0.00
Total Sheet Metal Shop			\$0.00
Total Material, Equipment, & Labor			\$104.35
Subcontractors			
Murray Paint			\$6,658.00
Centennial			\$0.00
Grand River			\$0.00
Total Subcontractors			\$6,658.00
Subtotal			\$6,762.35
	15.00%		
Total Value of Extra			\$7,776.70



DATE: 6-23-2023

PROJECT: Jackson WWTP

SECTIONS: Painting, RFI #31 Scum Wall Sleeves

FROM: Tyler Lonsway

Cost Change: \$6,658.00

INCLUDES:

- **Sandblasting and Coating Scum Wall Sleeves**

Please let me know if you need anything else,

THANKS,

*Tyler Lonsway
Murray Painting
Project Manager
989-695-8152 Office
989-225-7247 Cell*

BULLETIN
PAGE 1 OF 2

CONTRACT FOR:	WWTP CWSRF 2022 Improvements
OWNER:	City of Jackson 161 West Michigan Avenue Jackson, MI 49201
CONTRACTOR:	Allied Mechanical Services, Inc. 3860 Roger B Chaffee Memorial Dr., SE Grand Rapids, MI 49548
ENGINEER:	Fishbeck 39500 MacKenzie Drive, Suite 100 Novi, MI 48377
DRAWING REVISION NO.:	B2
ISSUED HEREWITH:	
SPECIFICATION SECTIONS:	None
SHEETS:	DA201, A201

The items below are being considered as possible changes to the Contract Documents for this Project. Contractor is requested to submit changes in cost, if any, for each item and indicate whether it is an addition to or deduction from the Contract Price. Costs are requested as lump sums unless otherwise noted as a unit cost. Include all labor, materials, overhead and profit, trades, subcontractors, and related costs. After reviewing the effects of those changes in the Work, Owner may issue a Change Order specifying which changes are to be incorporated in the Work, if any.

This Bulletin is not a Change Order and is not to be deemed authorization to proceed with the changes listed.

Additional work or materials, where proposed, shall meet the requirements of the Contract Documents, except where noted.

Contractor is responsible for notifying Engineer, in writing, concerning any revision or clarification which causes a change in the Contract Documents, but not specifically mentioned as a cost item in this Bulletin.

Return one completed and signed copy of the Bulletin to Engineer on or before the due date noted above.

Each proposed change has been described briefly with additional information provided concerning detailed changes required for the major trades concerned. Only one total cost figure has been requested for each item on the Bulletin; however, a complete breakdown is required for each item as supporting documentation. This will allow Owner to more easily evaluate the proposed cost changes. Each Bulletin item is an all-inclusive item and may concern work from several trades or Subcontractors. It is Contractor's responsibility to ensure that all work for each item has been included in the total cost figure provided to Owner.

ITEM NO. 1: Cable Tray Penetrations
Sheets DA201 – Blower Building Architectural Demolition Plan (reissued)
A201 – Blower Building Floor Plan (reissued)

- A. Remove existing electrical busway. Provide masonry wall infill where existing electrical busway is removed.
- B. Remove masonry and provide lintels for new cable tray penetrations at two additional wall locations (three locations total).

~~ADD~~ DEDUCT: \$ 26,040.00

BULLETIN
PAGE 2 OF 2

Contractor: **Allied Mechanical Services**

Bob Sweet  Digitally signed by Bob Sweet

Signature

Bob Sweet Project Manager





Name and Title of Signatory

6-27-23

Date

END OF BULLETIN

DEMOLITION SYMBOL LEGEND

-  EXISTING WALLS TO REMAIN
-  EXISTING WALLS TO BE REMOVED
-  EXISTING DOOR TO REMAIN
-  EXISTING DOOR TO BE REMOVED

GENERAL DEMOLITION NOTES

1. GENERAL DEMOLITION NOTES, KEYED DEMOLITION NOTES AND SPECIFICATIONS (DIVISION 02 - EXISTING CONDITIONS) APPLY TO ARCHITECTURAL DEMOLITION PLANS INCLUDED WITHIN THIS DOCUMENT SET.
2. THESE DEMOLITION NOTES AND PLANS DO NOT FULLY REPRESENT ALL DEMOLITION WORK REQUIRED TO INSTALL NEW WORK IN ACCORDANCE WITH CONTRACT DOCUMENTS, BUT ARE INTENDED TO SERVE AS GENERAL DEMOLITION GUIDELINES.
3. COORDINATE AND PHASE DEMOLITION IN ACCORDANCE WITH PLANS AND SPECIFICATIONS IN ORDER TO MAINTAIN BUILDING SECURITY, WEATHER TIGHTNESS, AND CONTINUING OPERATIONS FOR OWNER.
4. COORDINATE ALL DEMOLITION WORK WITH ALL OTHER CONSTRUCTION TRADES, INCLUDING PROCESS, STRUCTURAL, MECHANICAL, PLUMBING, AND ELECTRICAL.
5. ALL WORK INDICATED WITH SOLID LINES IS EXISTING TO REMAIN, UNLESS OTHERWISE NOTED.
6. FOR AREAS WITHIN THE BUILDING AND OUTLIER BUILDINGS WHICH ARE TO REMAIN OCCUPIED, PROVIDE AND MAINTAIN CONSTRUCTION BARRIER BETWEEN CONSTRUCTION AND OCCUPIED AREA.
7. ALL EX. FIRE RATED WALLS AND / OR SEPARATIONS (NOT SCHEDULED FOR DEMOLITION) ARE TO BE MAINTAINED DURING DEMOLITION WORK. IF FIRE RATED WALLS AND / OR SEPARATIONS ARE DISTURBED, PATCH, REPAIR AND / OR FIRE SEAL WALL AND / OR SEPARATION WITH RATED CONSTRUCTION TO MATCH EX. CONDITIONS.
8. ALL EX. CONDITIONS AND DIMENSIONS INDICATED ON DRAWINGS SHALL BE VERIFIED PRIOR TO DEMOLITION; COMMENCEMENT OF WORK CONSTITUTES ACCEPTANCE OF CONDITIONS.
9. PROVIDE INTERIOR AND/OR EXTERIOR SHORING, BRACING, OR SUPPORT AS REQUIRED TO PREVENT MOVEMENT, SETTLEMENT, DAMAGE, OR COLLAPSE OF THE STRUCTURE WHERE DEMOLITION WORK OCCURS.
10. ALL ITEMS NOT PART OF THE SCOPE OF DEMOLITION ARE TO BE PRESERVED AND PROTECTED THROUGHOUT THE DURATION OF DEMOLITION AND CONSTRUCTION. REPLACE, PATCH AND / OR REPAIR, AT NO COST TO OWNER, ALL DAMAGE WHICH OCCURRED TO EX. ITEMS TO REMAIN AND WHICH WERE NOT PART OF THE SCOPE OF DEMOLITION.
11. WHERE ITEMS ARE REMOVED OR OPENINGS ARE CUT INTO WALLS, PATCH SURFACES TO MATCH ADJACENT SURFACES OR TO RECEIVE NEW FINISHES WHERE SCHEDULED. PATCHING OF NEW OR EX. FINISHES SHALL EXTEND TO NEAREST NATURAL BREAK OR SURFACE TERMINATION FOR A CLEAN, UNBLENISHED APPEARANCE AT THE END OF CONSTRUCTION. REFER TO DEMOLITION KEYNOTES, ARCHITECTURE, PROCESS, MECHANICAL, PLUMBING, AND ELECTRICAL FOR ADDITIONAL DEMOLITION REQUIREMENTS AND / OR PATCH AND REPAIR REQUIREMENTS.

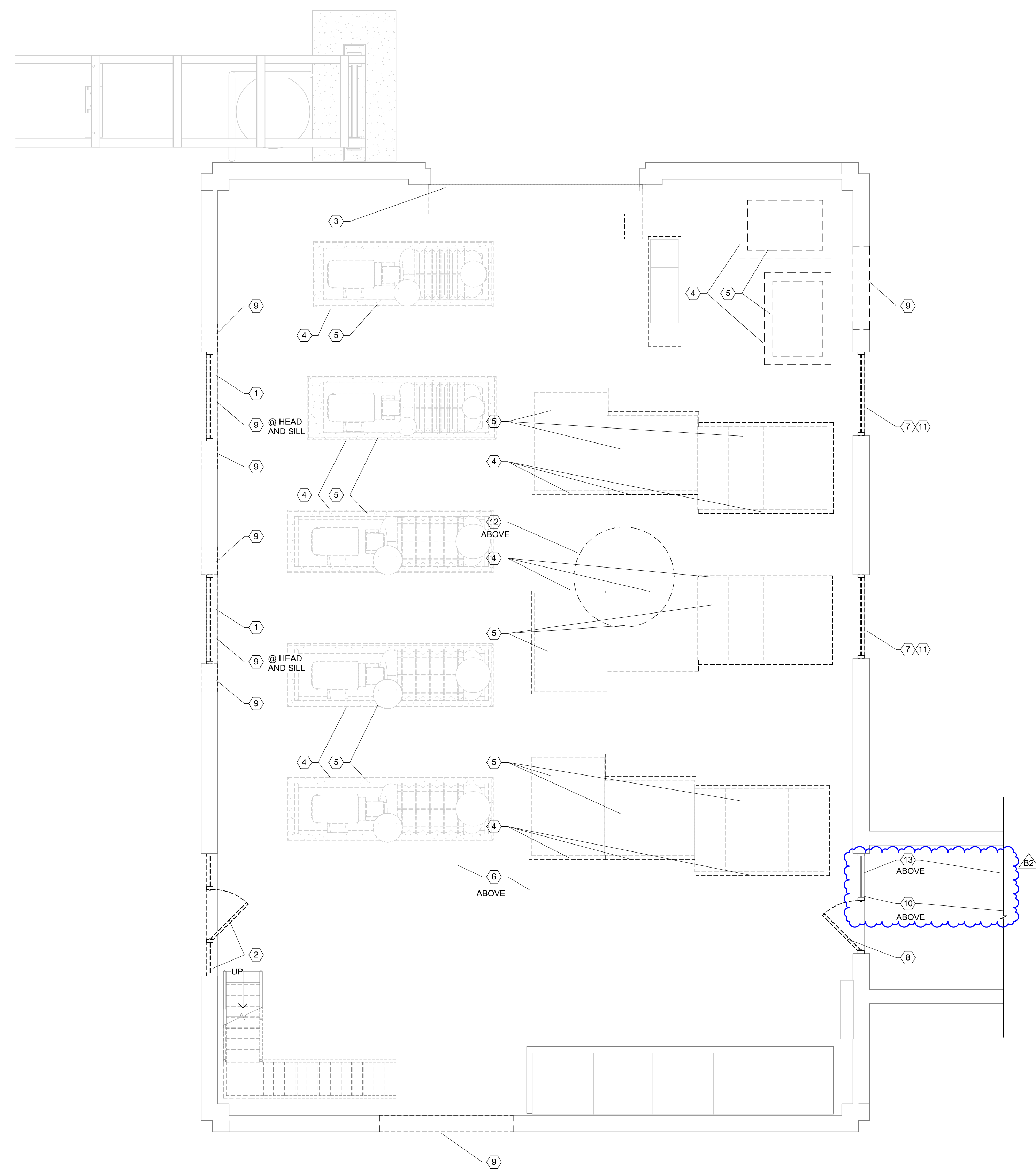

DEMOLITION NOTES

- 1 REMOVE EX. WINDOW UNIT IN ITS ENTIRETY.
- 2 REMOVE EX. WINDOW SYSTEM WITH GLASS ENTRANCE DOOR IN ITS ENTIRETY.
- 3 REMOVE EX. OVERHEAD DOOR WITH ALL ASSOCIATED HARDWARE, FRAME AND OPERATORS IN ITS ENTIRETY.
- 4 REMOVE EX. CONCRETE EQUIPMENT PAD, REFER TO MECH. AND STRUCT. FOR ADDITIONAL DETAILS AND INFORMATION.
- 5 DECOMMISSION AND REMOVE EX. EQUIPMENT IN ITS ENTIRETY, REFER TO PROCESS, MECH. AND ELECT.
- 6 REMOVE EX. CEILING PADS WITH GRID AND HANGERS IN ITS ENTIRETY FROM ROOM / AREA.
- 7 REMOVE EX. LOUVER IN ITS ENTIRETY, REFER TO MECH.
- 8 REMOVE EX. ALUMINUM AND GLASS DOOR WITH HARDWARE IN ITS ENTIRETY. ALUMINUM FRAME AND SIDELITE GLAZING TO REMAIN.
- 9 SAWCUT AND REMOVE EXISTING BRICK VENEER AND CMU BACK-UP WYTHE WALL AS REQUIRED FOR NEW LINTEL AND MECHANICAL LOUVER, REFER TO NEW WORK DRAWINGS, STRUCT. AND MECH. FOR LOCATION, INFORMATION AND DETAILS. SHORE EX. CONSTRUCTION AS REQ'D. UNTIL NEW STRUCTURE IS INSTALLED.
- 10 SAWCUT AND REMOVE EX. BRICK VENEER AND CMU BACK-UP WYTHE AS REQUIRED FOR NEW CABLE TRAY PENETRATION AND NEW LINTEL (3 LOCATIONS IN TOTAL - BLOWER BUILDING, POWERHOUSE BUILDING AND INSIDE POWERHOUSE BUILDING). REFER TO NEW WORK DRAWING, STRUCT. AND ELECT. FOR LOCATION, INFORMATION AND DETAILS. SHORE EX. CONSTRUCTION AS REQ'D. UNTIL NEW STRUCTURE IS INSTALLED.
- 11 REMOVE EX. SILL AT LOUVER OPENING
- 12 REMOVE EX. FAN AND ASSOCIATED CURB IN ITS ENTIRETY, REFER TO MECH.
- 13 REMOVE EX. ELECTRICAL BUSWAY BETWEEN BLOWER BUILDING AND POWERHOUSE BUILDING IN ITS ENTIRETY, REFER TO ELECTRICAL FOR DETAILS AND INFORMATION.

REVISIONS	
6/26/2023	B2 BULLETIN 2

10/26/2022 FOR CONSTRUCTION	
Drawn By	CLF
Designer	CLF
Reviewer	YB
Manager	EHS

Hard copy is intended to be 24"x36" when plotted. Scale(s) indicated and graphic quality may not be accurate for any other size.

PROJECT NO.
210403
SHEET NO.

DA201

BLOWER BUILDING
DEMOLITION PLAN
SCALE: 1/4" = 1'-0"
NORTH

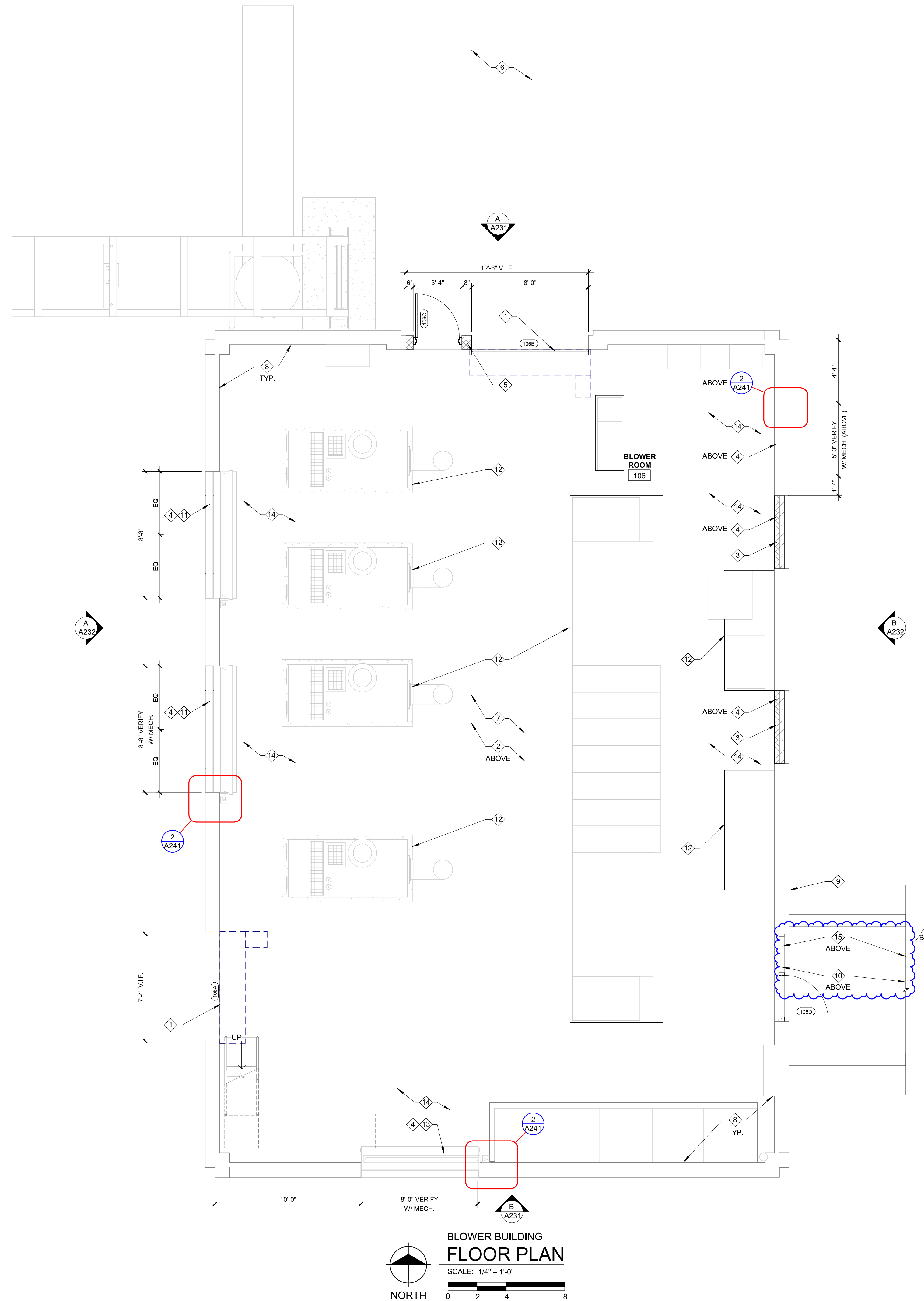

**BLOWER BUILDING
FLOOR PLAN**
SCALE: 1/4" = 1'-0"
NORTH

FLOOR PLAN SYMBOL LEGEND

- INTERIOR WALL TYPE; REFER TO SHEET AXXX
- DOOR NUMBER
- CMU WALL
- FACE BRICK
- CAST IN PLACE OR PRECAST CONCRETE
- EXISTING WALL
- EXISTING DOOR
- NEW DOOR
- FLOOR DRAIN; REFER TO MECHANICAL
- STEEL LADDER, WALL MOUNTED
- ROOF HATCH ABOVE

GENERAL NOTES

1. COORDINATE ALL WORK INDICATED PER THE PROJECT MANUAL AND DRAWINGS - NOTE: THE MOST STRINGENT REQUIREMENT OR MORE COSTLY WORK SHALL GOVERN WHERE CONFLICTS OCCUR.
2. IF AREAS WITHIN THE BUILDING ARE TO REMAIN OCCUPIED, PROVIDE AND MAINTAIN CONSTRUCTION BARRIER BETWEEN CONSTRUCTION AND OCCUPIED AREA.
3. COORDINATE PHASING AND SEQUENCING OF THE WORK TO MAINTAIN BUILDING SECURITY AND WEATHER TIGHTNESS.
4. ALL EX. FIELD CONDITIONS PERTAINING TO THE EX. BUILDING CONSTRUCTION INCLUDING BUT NOT LIMITED TO: DIMENSIONS, WALL CONSTRUCTION, WALL CAVITIES, CONCEALED STRUCTURE, ETC. ARE TO BE VERIFIED IN FIELD PRIOR TO CONSTRUCTION; NOTIFY OWNER AND ARCHITECT IN WRITING IF CONDITIONS DIFFER FROM DRAWINGS OR IF UNFORESEEN CONDITIONS OCCUR. COMMENCEMENT OF WORK WITHOUT NOTIFYING OWNER AND ARCHITECT IN WRITING CONSTITUTES ACCEPTANCE OF CONDITIONS.
5. PROVIDE INTERIOR AND/OR EXTERIOR SHORING, BRACING, OR SUPPORT AS REQUIRED TO PREVENT MOVEMENT, SETTLEMENT, DAMAGE, OR COLLAPSE OF THE STRUCTURE WHERE WORK OCCURS.
6. COORDINATE ALL CUT, PATCH, AND REPAIR WORK WITH ALL OTHER TRADES, INCLUDING PROCESS, MECHANICAL, PLUMBING AND ELECTRICAL DRAWINGS. PATCHING OF FINISHES SHALL EXTEND TO NEAREST NATURAL BREAK OR SURFACE TERMINATION FOR A CLEAN, UNBLEMISHED APPEARANCE AT THE END OF CONSTRUCTION.
7. PATCH, REPAIR AND PAINT ALL DAMAGED, DENTED, DETERIORATED, ETC. EX. CMU WALLS, PLASTER AND GYPSUM BOARD WALLS WITHIN AREA OF WORK WHICH ARE TO REMAIN AND ARE SCHEDULED TO BE PAINTED, REFER TO SCHEDULES.
8. MAIN FLOOR ELEVATIONS: (USGS) ELEVATION 915.0' = 915'-0".
9. ALL DIMENSIONS ON FLOOR PLANS ARE SHOWN TO FINISHED FACE OF WALL, UNLESS OTHERWISE NOTED. REFER TO ENLARGED FLOOR PLANS, SECTIONS, AND DETAILS FOR OTHER DIMENSIONS.
10. TOP OF SIDEWALK OUTSIDE OF EXIT DOORS SHALL BE HELD 1/4" BELOW FINISHED FLOOR.
11. REFER TO STRUCTURAL DRAWINGS FOR ALL STEEL SHAPES AND SIZES.
12. COORDINATE FIXTURES WITH PROCESS, MECHANICAL AND ELECTRICAL DRAWINGS.
13. REFER TO PROCESS, MECHANICAL, PLUMBING, AND ELECTRICAL DRAWINGS FOR COMPLETE LISTING OF ALL INTERIOR PENETRATIONS, EXTERIOR WALL / ROOF PENETRATIONS, ROOF TOP EQUIPMENT AND NEW INTERIOR EQUIPMENT.
14. ALL BLOCKING / SHEATHING SHALL BE EXTERIOR GRADE.
15. ROOF SLOPE SHALL BE 1/4:12 SLOPE MINIMUM, INCLUDING RESULTANT SLOPE AT VALLEYS; CONTRACTOR TO VERIFY ROOF DECK CONDITION AND COORDINATE ROOF SYSTEM INSTALLATION REQUIREMENTS PRIOR TO COMMENCING ROOFING WORK.
16. COORDINATE INSTALLATION OF FLASHING TO PROVIDE CONTINUITY, END DAMS, AND TERMINATIONS THAT DIRECT MOISTURE OUT OF THE BUILDING; COORDINATE WITH BUILDING AIR / MOISTURE BARRIER SYSTEMS.
17. AT ALL LOCATIONS WHERE EX. FIREPROOFING (SPRAY-ON AND / OR OTHERWISE) HAS BEEN DISTURBED FOR DEMOLITION AND NEW WORK - NEW FIREPROOFING IS TO BE PROVIDED TO MEET REQUIRED RATING ONCE NEW WORK CONSTRUCTION HAS BEEN COMPLETED.
18. PROVIDE MODIFICATION / REPAIR / REPLACEMENT OF EXISTING CONSTRUCTION AND FINISHES THAT ARE REQUIRED TO BE REMOVED FOR COMPLETION OF NEW WORK.
19. CORE EXISTING WALLS (CORE TO NOT BE BIGGER THAN NECESSARY FOR PENETRATION) CUT CLEANLY AS REQUIRED FOR NEW PIPE, CONDUIT OR DUCT INSTALLATION. REFER TO PROCESS, MECHANICAL, PLUMBING, AND ELECTRICAL FOR LOCATIONS.

KEY NOTES

- 1 NEW INSULATED MANUAL OVERHEAD DOOR. REFER TO SCHEDULES.
- 2 PAINT EX. AND NEW EXPOSED TO VIEW ROOF DECK, BRACING, PIPING, DUCTS, CONDUIT, AND ASSOCIATED ACCESSORIES AND APPURTENANCES. REFER TO SCHEDULES.
- 3 INFILL EX. OPENING WITH BRICK VENEER WITH CMU BACK-UP WYTHE FOR NEW LOUVER SIZE (INFILL TO OCCUR BELOW LOUVER), BRICK VENEER TO MATCH EX. ADJACENT BRICK VENEER (SIZE, COLOR, TEXTURE, COURSING AND MORTAR), REFER TO MECH. FOR LOUVER SIZE.
- 4 PRE-FINISHED ALUM. MECHANICAL LOUVER WITH BUG SCREEN, REFER TO MECH.
- 5 BRICK VENEER WITH CMU BACK-UP WYTHE INFILL. BRICK VENEER TO MATCH EX. ADJACENT BRICK VENEER (SIZE, COLOR, TEXTURE, COURSING AND MORTAR), REFER TO STRUCT. FOR NEW LINTEL INFORMATION.
- 6 EXISTING VALVE VAULT (APPROXIMATELY 20' FROM NORTH WALL) TO BE FIELD VERIFIED PRIOR TO CONSTRUCTION. REFER TO CIVIL.
- 7 CLEAN AND RESEAL EX. EXPOSED CONCRETE FLOOR.
- 8 PAINT MASONRY WALLS (EXISTING MASONRY AND INFILL MASONRY), REFER TO SCHEDULES.
- 9 TOOTH-IN NEW BRICK VENEER AND CMU BACK-UP WYTHE WHERE EX. BUSWAY WAS REMOVED. BRICK VENEER TO MATCH EX. ADJACENT BRICK VENEER (SIZE, COLOR, TEXTURE, COURSING AND MORTAR).
- 10 NEW BRICK VENEER INFILL OVER NEW LINTEL FOR NEW CABLE TRAY PENETRATION (3 LOCATIONS IN TOTAL - BLOWER BUILDING, POWERHOUSE BUILDING AND INSIDE POWERHOUSE BUILDING). BRICK VENEER TO MATCH EX. ADJACENT BRICK VENEER (SIZE, COLOR, TEXTURE, COURSING AND MORTAR). PROVIDE L6 X 3 1/2 X 5/16 LINTEL AT EACH COURSE OF BRICK WITH 8" BEARING AT EACH END OF LINTEL. OPENING SIZE SHALL NOT EXCEED 2'-6" CLEAR SPAN.
- 11 CENTER NEW LOUVER OPENING (WIDTH) ON EXISTING REMOVED LOUVER OPENING (WIDTH).
- 12 NEW CONCRETE EQUIPMENT PAD. REFER TO PROCESS, MECH. AND ELECT. FOR LOCATION AND SIZING. REFER TO STRUCT. FOR DETAILS AND INFORMATION. PAINT PAD SAFETY YELLOW.
- 13 FIELD VERIFY AND COORDINATE LOCATION OF LOUVER IN FIELD TO AVOID CLASH WITH EX. STAIR RUN.
- 14 REFER TO MECH. AND STRUCT. FOR SUPPORT FRAMING / BRACING AS REQUIRED FOR FANS / EQUIPMENT.
- 15 NEW BRICK VENEER AND CMU BACK-UP WYTHE INFILL WHERE EX. ELECTRICAL BUSWAY HAS BEEN REMOVED. INFILL TO OCCUR AT BOTH BLOWER BUILDING AND POWERHOUSE BUILDING WHERE BUSWAY WAS REMOVED.

REVISIONS	
6/26/2023	B2 BULLETIN 2

10/26/2022 FOR CONSTRUCTION

Drawn By CLF
Designer CLF
Reviewer YB
Manager EHS

Hard copy is intended to be 24"x36" when plotted. Scale(s) indicated and graphic quality may not be accurate for any other size.

PROJECT NO.
210403

SHEET NO.

A201



June 7, 2023
Attn: Erin Szczegielniak
Fishbeck
Jackson WWTP CWSRF 2022 Improvements
RE: RFI #42 Cable Tray Lintels

48

Allied Mechanical Services, Inc. proposes to provide all labor, supervision, and material for the following scope of work.

- Provide and install lintels for cable tray in two masonry power house walls.

Total Cost\$26,040.00

Pricing is firm for 30 days.

Sincerely,

Bob Sweet

Allied Mechanical Services, Inc.
5688 East ML Ave
Kalamazoo, MI 49048
bsweet@alliedmechanical.com
Cell: 269-998-3138

Allied Mechanical Services

Cost summary

Jackson WWTP RF1 48

Date;

6/7/2023

Material	Rate	Hours/Units	Total
			\$0.00
Equipment			
Total Material & Equip			\$0.00
Labor			
Project Manager	\$108.70		\$0.00
Foreman	\$104.35	4	\$417.40
Journeyman	\$100.00	0	\$0.00
Apprentice	\$88.70	0	\$0.00
Safety Rep	\$108.70	0	\$0.00
Total Piping Labor			\$417.40
OT Premium			
Foreman 1-1/2	\$41.74	0	\$0.00
Foreman Double	\$83.48	0	\$0.00
Journeyman 1-1/2	\$40.00	0	\$0.00
Journeyman Double	\$80.00	0	\$0.00
Total OT Premium			\$0.00
Sheet Metal Shop Labor			
Foreman	\$108.70	0	\$0.00
Journeyman	\$100.00	0	\$0.00
Foreman OT	\$41.74	0	\$0.00
Journeyman OT	\$40.00	0	\$0.00
Total Sheet Metal Shop			\$0.00
Total Material, Equipment, & Labor			\$417.40
Subcontractors			
Murray Paint			\$0.00
Centennial			\$0.00
Grand River			\$22,226.00
Total Subcontractors			\$22,226.00
Subtotal			\$22,643.40
	15.00%		
Total Value of Extra			\$26,039.91



Grand River Construction, Inc.

General Contractors • Commercial and Industrial • Concrete Specialist

June 5, 2023

Mr. Bob Sweet
Allied Mechanical Services, Inc.
5688 E ML Avenue A
Kalamazoo, MI 49048

RE: Jackson WWTP CWSRF 2022 Improvements
Change Request – Cable Tray Penetrations at Blower Bldg. & Powerhouse (RFI_48)

Dear Mr. Sweet,

Please see the attached pricing as requested for the scope of work associated with RFI_48.

RFI 48 Work Scope:

- Furnish, deliver & install six (6) new lintels, three (3) lintels at two (2) locations.
- Limited demolition for installation of new lintels at two (2) locations.
- Tooth-in masonry infill (match existing) around new lintels at two (2) locations.
- Installation & removal of protective covering of work area with 6-mil visqueen.
- Removal and re-installation of existing ceiling grid drop tile.
- Tooth-in masonry infill (match existing) at Powerhouse and Blower Bldg. walls where the existing electrical bus is removed.

Exclusions:

- New ceiling grid. Existing grid will be re-installed following cable tray work.
- Lock-out/Tag-out.
- Shoring/bracing.
- Removal of existing furnishings in work area. It is assumed that this will be done by plant personnel prior to demolition.

Firm Lump Sum..... \$22,226.00

Sincerely,

GRAND RIVER CONSTRUCTION, INC.

Dave Nyhuis
Project Manager & Estimator

REFERENCE: RFI_48 DATE: 6/5/2023

PROJECT: Jackson WWTP CWSRF Improvements Project

DESCRIPTION: Remove existing ceiling grid in corridor between Blower Bldg. & Powerhouse for new cable tray.

Furnish & install six (6) 6" x 3.5" x 5/16" with red oxide primer finish at powerhouse wall and corridor;
Includes limited demolition of brick for install of new lintels; Brick to be toothed back in following lintel
installation; Infill penetration in two (2) walls following removal of existing bus. GRC to protect work area
by installing protective Visqueen. GRC to re-install ceiling grid following installation of cable tray. Weather
tight penetrations on exterior to be provided by others. Pricing does not include furnishing new ceiling grid.
Existing furnishings to be relocated by plant personnel prior to start of demolition. Centennial Electric to
assist with layout for lintel locations for cable tray.

A. Equipment, Materials, and Supplies

Lintel Supply		1,775.00	
GRC Trucking		650.00	
SkyTrak (1 day)		520.00	
Visqueen & accessories		525.00	
Small Tools		150.00	
		<u>3,620.00</u>	
	Subtotal	3,620.00	
	Sales Tax 6%	217.20	
	Overhead 10%	383.72	
	Material Total	<u>4,220.92</u>	4,220.92

B. Labor:

<u>Trade</u>	<u>Hours</u>	<u>Rate</u>		
Project Foreman	16.00	\$95.00	1,520.00	
Carpenter	32.00	\$62.19	1,989.96	
Laborer	128.00	\$47.84	6,124.03	
Finisher	0.00	\$60.37	0.00	
Operator	0.00	\$78.71	0.00	
			<u>9,634.00</u>	
		Subtotal	9,634.00	
		Overhead 15%	1,445.10	
		Labor Total	<u>11,079.10</u>	11,079.10

C. Subcontractors

Complete Enclosures		<u>6,296.00</u>	
		Subtotal	6,296.00
		Overhead 10%	<u>629.60</u>
		Subcontractor Total	<u>6,925.60</u>
		TOTAL A+B+C	<u>22,225.62</u>
		TOTAL:	<u>22,226.00</u>

6/2/2023

Change Request 1

PROJECT: Jackson WWTP Blower Building

TO: Grand River Construction
 David Nyhuis

FROM: Keith Davenport
 Complete Enclosures, Inc
 3651 Toles Rd
 Mason, MI 48854

Scope: RFI 48 clarified that additional holes will need to be cut into the existing power house walls, lintels added in triple-wythe brick walls, and the holes to be toothed in around the new cable tray.

	Hours	Rate	Burden (27%)	total
Bricklayer Foreman	16	\$ 56.36	\$ 15.22	\$ 1,145.24
Bricklayer	32	\$ 54.23	\$ 14.64	\$ 2,203.91
Laborer	32	\$ 40.51	\$ 10.94	\$ 1,646.33
				<u>\$ 4,995.47</u>
Material				
Brick, Mortar				\$ 164.00
				<u>\$ -</u>
				\$ 164.00
Equipment				
Scaffold, Ladders, Hammerdrill, Saw, Blades, Floor Protection				\$ 315.00
				<u>\$ -</u>
				\$ 315.00
 SUBTOTAL				 \$ 5,474.47
 Markup 15%				 <u>\$ 821.17</u>
 TOTAL				 <u><u>\$ 6,296</u></u>

Sincerely,

Keith Davenport
kdavenport@completeenclosures.com
 517-881-2918



CERTIFIED
SHEET METAL

1665 Holton Road Muskegon, Mi 49445-1498
Phone 231.744.2461 Fax 231.744.9156

Please visit our website at www.certifiedsheetmetal.com

May 25, 2023

Grand River Construction
Hudsonville, MI

Carbon Steel Lintels

Dave

We are pleased to submit our quotation to provide the labor, materials, and equipment to perform the following.

Fabricate and Deliver

- 6- CSM will fabricate and deliver six carbon steel lintels using 6"x 3 1/2" x 5/16" angles at a length of 46" each. Once fabricated they will be red oxide primed.

Total	\$1,775.00
--------------	-------------------

All orders accepted by us with the understanding that we are not to be held liable for non-delivery because of transportation difficulties, labor strikes, fire, defense priorities, war, flood, accidents at factory or any other cause beyond our control.

It is hereby expressly understood and agreed that no verbal statements or agreements made by any agent or representative of the company, nor by any person on its behalf, shall be binding upon the company unless explicitly set forth in this proposal.

All prices quoted are subject to change without notice. Terms: Net due within ten (10) days from date of invoice. Any unpaid balance after thirty (30) days from date of billing is subject to 1 1/2 % per month which amounts to 18 % per year.

This proposal is subject to your acceptance within thirty (30) days and to approval by an officer of the company. When so approved (and not before) it will constitute a contract between us.

CERTIFIED SHEET METAL, LLC

NATE HESSE Project Manager

ACCEPTED:

APPROVED:
CERTIFIED SHEET METAL, LLC

by _____

by _____

date _____

date _____

MEMO TO: Mayor and City Councilmembers
FROM: Jonathan Greene, City Manager
DATE: July 11, 2023
SUBJECT: 2023/2024 Nonunion Pay Scale

Recommendation:

Adopt an ordinance regulating nonunion pay for the City of Jackson employees.

Attached is a pay scale for nonunion employees reflecting a 3% increase in wages. This increase was anticipated in the development and approval of the fiscal year 2023/2024 budget.

I recommend approval and this change to be retroactive to July 1, 2023.

Your consideration and concurrence are appreciated.

DEPARTMENTAL REPORT

MEMO TO: Jonathan Greene, City Manager
FROM: Heather Ehnis, Finance Director
DATE: July 11, 2023
RECOMMENDATION: 2023/2024 Nonunion Pay Scale

SUMMARY

The Personnel and Labor Relations Department respectfully requests the adoption of the Nonunion employee pay scale.

BUDGETARY CONSIDERATIONS

A 3% wage increase for Nonunion personnel was factored into the development and approval of the fiscal year 2023/2024 budget.

HISTORY, BACKGROUND and DISCUSSION

Compensation rates for Nonunion employees are approved by City Council. Historically, Nonunion personnel raises lag behind those of the other bargaining units.

DISCUSSION OF THE ISSUE

The attached wage scale is reflective of a 3% increase at each pay grade and step.

POSITIONS

Recommend approval.

ATTACHMENTS

SCHEDULE I
Administrative and Supervisory Employee
Pay Rates

Effective: 7/1/2023
Increase: 3.00%

Class Grade	Pay Basis	Minimum										Maximum
		Step 1	Step 1-1/2	Step 2	Step 3	Step 4	Step 5	Step 6	Step 7	Step 8	Step 9	
4	Annual	40,317	41,004	41,688	43,099	44,564	46,076	47,641	49,255	50,929	52,655	54,444
	Bi-Weekly	1,550.65	1,577.08	1,603.38	1,657.65	1,714.00	1,772.15	1,832.35	1,894.42	1,958.81	2,025.19	2,094.00
	Hourly	19.3831	19.7135	20.0423	20.7206	21.4250	22.1519	22.9044	23.6803	24.4851	25.3149	26.1750
5	Annual	42,627	43,353	44,077	45,566	47,105	48,703	50,347	52,057	53,821	55,640	57,524
	Bi-Weekly	1,639.50	1,667.42	1,695.27	1,752.54	1,811.73	1,873.19	1,936.42	2,002.19	2,070.04	2,140.00	2,212.46
	Hourly	20.4938	20.8428	21.1909	21.9068	22.6466	23.4149	24.2053	25.0274	25.8755	26.7500	27.6558
6	Annual	44,941	45,699	46,458	48,030	49,651	51,328	53,066	54,857	56,712	58,623	60,605
	Bi-Weekly	1,728.50	1,757.65	1,786.85	1,847.31	1,909.65	1,974.15	2,041.00	2,109.88	2,181.23	2,254.73	2,330.96
	Hourly	21.6063	21.9706	22.3356	23.0914	23.8706	24.6769	25.5125	26.3735	27.2654	28.1841	29.1370
7	Annual	47,507	48,317	49,124	50,799	52,525	54,316	56,160	58,073	60,042	62,088	64,204
	Bi-Weekly	1,827.19	1,858.35	1,889.38	1,953.81	2,020.19	2,089.08	2,160.00	2,233.58	2,309.31	2,388.00	2,469.38
	Hourly	22.8399	23.2294	23.6173	24.4226	25.2524	26.1135	27.0000	27.9198	28.8664	29.8500	30.8673
8	Annual	50,331	51,190	52,047	53,823	55,659	57,555	59,514	61,544	63,640	65,810	68,057
	Bi-Weekly	1,935.81	1,968.85	2,001.81	2,070.12	2,140.73	2,213.65	2,289.00	2,367.08	2,447.69	2,531.15	2,617.58
	Hourly	24.1976	24.6106	25.0226	25.8765	26.7591	27.6706	28.6125	29.5885	30.5961	31.6394	32.7198
9	Annual	52,133	53,123	54,115	56,172	58,307	60,521	62,820	65,215	67,686	70,260	72,932
	Bi-Weekly	2,005.12	2,043.19	2,081.35	2,160.46	2,242.58	2,327.73	2,416.15	2,508.27	2,603.31	2,702.31	2,805.08
	Hourly	25.0640	25.5399	26.0169	27.0058	28.0323	29.0966	30.2019	31.3534	32.5414	33.7789	35.0635
10	Annual	55,727	56,791	57,851	60,061	62,358	64,731	67,209	69,773	72,435	75,201	78,069
	Bi-Weekly	2,143.35	2,184.27	2,225.04	2,310.04	2,398.38	2,489.65	2,584.96	2,683.58	2,785.96	2,892.35	3,002.65
	Hourly	26.7919	27.3034	27.8130	28.8755	29.9798	31.1206	32.3120	33.5448	34.8245	36.1544	37.5331
11	Annual	59,323	60,449	61,571	63,915	66,335	68,852	71,467	74,178	76,991	79,916	82,949
	Bi-Weekly	2,281.65	2,324.96	2,368.12	2,458.27	2,551.35	2,648.15	2,748.73	2,853.00	2,961.19	3,073.69	3,190.35
	Hourly	28.5206	29.0620	29.6015	30.7284	31.8919	33.1019	34.3591	35.6625	37.0149	38.4211	39.8794
12	Annual	63,177	64,373	65,572	68,062	70,647	73,324	76,111	78,999	81,999	85,114	88,344
	Bi-Weekly	2,429.88	2,475.88	2,522.00	2,617.77	2,717.19	2,820.15	2,927.35	3,038.42	3,153.81	3,273.62	3,397.85
	Hourly	30.3735	30.9485	31.5250	32.7221	33.9649	35.2519	36.5919	37.9803	39.4226	40.9203	42.4731
13	Annual	67,280	68,566	69,853	72,519	75,281	78,156	81,136	84,233	87,447	90,784	94,246
	Bi-Weekly	2,587.69	2,637.15	2,686.65	2,789.19	2,895.42	3,006.00	3,120.62	3,239.73	3,363.35	3,491.69	3,624.85
	Hourly	32.3461	32.9644	33.5831	34.8649	36.1928	37.5750	39.0078	40.4966	42.0419	43.6461	45.3106
14	Annual	71,394	72,750	74,107	76,930	79,852	82,890	86,035	89,316	92,713	96,236	99,897
	Bi-Weekly	2,745.92	2,798.08	2,850.27	2,958.85	3,071.23	3,188.08	3,309.04	3,435.23	3,565.88	3,701.38	3,842.19
	Hourly	34.3240	34.9760	35.6284	36.9856	38.3904	39.8510	41.3630	42.9404	44.5735	46.2673	48.0274
15	Annual	75,248	76,674	78,103	81,077	84,159	87,366	90,685	94,136	97,719	101,433	105,296
	Bi-Weekly	2,894.15	2,949.00	3,003.96	3,118.35	3,236.88	3,360.23	3,487.88	3,620.62	3,758.42	3,901.27	4,049.85
	Hourly	36.1769	36.8625	37.5495	38.9794	40.4610	42.0029	43.5985	45.2578	46.9803	48.7659	50.6231

Class Grade	Pay Basis	Minimum										Maximum
		Step 1	Step 1-1/2	Step 2	Step 3	Step 4	Step 5	Step 6	Step 7	Step 8	Step 9	
16	Annual	79,098	80,602	82,106	85,231	88,474	91,839	95,329	98,955	102,721	106,627	110,683
	Bi-Weekly	3,042.23	3,100.08	3,157.92	3,278.12	3,402.85	3,532.27	3,666.50	3,805.96	3,950.81	4,101.04	4,257.04
	Hourly	38.0279	38.7510	39.4740	40.9765	42.5356	44.1534	45.8313	47.5745	49.3851	51.2630	53.2130
17	Annual	82,949	84,526	86,103	89,381	92,773	96,309	99,971	103,778	107,726	111,823	116,075
	Bi-Weekly	3,190.35	3,251.00	3,311.65	3,437.73	3,568.19	3,704.19	3,845.04	3,991.46	4,143.31	4,300.88	4,464.42
	Hourly	39.8794	40.6375	41.3956	42.9716	44.6024	46.3024	48.0630	49.8933	51.7914	53.7610	55.8053
18	Annual	87,060	88,721	90,381	93,832	97,417	101,136	104,999	109,012	113,175	117,499	121,984
	Bi-Weekly	3,348.46	3,412.35	3,476.19	3,608.92	3,746.81	3,889.85	4,038.42	4,192.77	4,352.88	4,519.19	4,691.69
	Hourly	41.8558	42.6544	43.4524	45.1115	46.8351	48.6231	50.4803	52.4096	54.4110	56.4899	58.6461
19	Annual	91,938	93,685	95,434	99,064	102,836	106,748	110,808	115,027	119,402	123,943	128,657
	Bi-Weekly	3,536.08	3,603.27	3,670.54	3,810.15	3,955.23	4,105.69	4,261.85	4,424.12	4,592.38	4,767.04	4,948.35
	Hourly	44.2010	45.0409	45.8818	47.6269	49.4404	51.3211	53.2731	55.3015	57.4048	59.5880	61.8544
20	Annual	96,818	98,665	100,512	104,343	108,319	112,450	116,740	121,192	125,817	130,610	135,593
	Bi-Weekly	3,723.77	3,794.81	3,865.85	4,013.19	4,166.12	4,325.00	4,490.00	4,661.23	4,839.12	5,023.46	5,215.12
	Hourly	46.5471	47.4351	48.3231	50.1649	52.0765	54.0625	56.1250	58.2654	60.4890	62.7933	65.1890
21	Annual	131,127	134,406	137,683	140,962	144,240	147,519	150,796	154,075	157,353	160,631	163,909
	Bi-Weekly	5,043.35	5,169.46	5,295.50	5,421.62	5,547.69	5,673.81	5,799.85	5,925.96	6,052.04	6,178.12	6,304.19
	Hourly	63.0419	64.6183	66.1938	67.7703	69.3461	70.9226	72.4981	74.0745	75.6505	77.2265	78.8024
22	Annual	142,273	148,516	153,294	159,116	165,162	171,441	177,955	184,717	191,738	199,023	206,710
	Bi-Weekly	5,472.04	5,712.15	5,895.92	6,119.85	6,352.38	6,593.88	6,844.42	7,104.50	7,374.54	7,654.73	7,950.38
	Hourly	68.4005	71.4019	73.6990	76.4981	79.4048	82.4235	85.5553	88.8063	92.1818	95.6841	99.3798

MEMO TO: Mayor and City Councilmembers

FROM: Jonathan Greene, City Manager

DATE: July 11th, 2023

SUBJECT: Approve Conditional Phase One Facility License for a Marihuana Microbusiness Establishment as per Ordinance No. 2020-15

Recommendation:

Approve conditional phase one facility license for Five Point Farms LLC, Marihuana Microbusiness at 744 E South St, per Ordinance No. 2020-15. Authorize the City Manager to sign the Development Agreement and make minor modifications as necessary.

Based upon the due diligence on the part of City staff and the commitments on the part of the applicant, I recommend granting a conditional phase one facility license to the above noted applicant. Your consideration and concurrence is appreciated.

Attachments: Attached is the memo from Shane LaPorte, Director Neighborhood and Economic Operations, along with the associated pre-qualification letter, select sheets from the approved site/facility plans, social equity plan:

744 E. South St

DEPARTMENTAL REPORT

MEMO TO: Jonathan Greene, City Manager

FROM: Shane LaPorte, Director of Community Development

DATE: Council Meeting- July 11th, 2023

RECOMMENDATION: Approve Conditional Phase One Facility License for Five Point Farms LLC, a Marijuana Microbusiness Establishment as Per Ordinance No 2020-15

SUMMARY

On April 13th, 2023, Five Point Farms LLC. Submitted an application for building and site plan review for a Marihuana Microbusiness to be located at 744 E. South St this was done in accordance with City Ordinance Section 16-516 License Application Process and Submissions. The applicant's site and building plans were reviewed by City Staff, all plans were found to be in accordance with building and site requirements. On June 23rd, 2023, the Marihuana License Committee met to review compliance with applicable ordinances that pertain to Phase 1 of the licensing process, it was determined that all criteria was met. The Marihuana License Review Committee voted unanimously to recommend City Council approve the Phase One Facilities License to Five Point Farms LLC.

BUDGETARY CONSIDERATIONS

At present there are no budgetary considerations because the applicant has submitted the requisite application fee and escrow funds intended to cover the associated staff time. However, these fees are not intended to cover building permit costs, each of which will be assessed separately

HISTORY, BACKGROUND and DISCUSSION

Ordinance No. 2020-15 clearly outlines the process for consideration of a marihuana facilities, including the use types, quantities, and timeframe. City Council is presently only considering the facility application (phase one) which affords the applicant the ability to seek a building permit no sooner than 30 days after Council action. Approval would also permit the City Manager to sign the development agreement which ensures that the applicant completes the project as denoted on the plans and accompanied future operational commitments. Building permits can be sought immediately thereafter. The subsequent review phase (entity) will not commence until a building permit is granted and will not end until up to twelve (12) months later or upon receipt of a Certificate of Occupancy.

POSITIONS

The application being recommended for conditional phase one facility license includes the following: 744 E South St, Five Point Farms LLC. Council approval will authorize the City Manager to sign the Development Agreement which effectuates the approved plans and submission package.

ATTACHMENTS:

JG



Form Revision Date 02/2017

ARTICLES OF ORGANIZATION
 For use by DOMESTIC LIMITED LIABILITY COMPANY

Pursuant to the provisions of Act 23, Public Acts of 1993, the undersigned executes the following Articles:

Article I

The name of the limited liability company is:

FIVE POINT FARMS, LLC

Article II

Unless the articles of organization otherwise provide, all limited liability companies formed pursuant to 1993 PA 23 have the purpose of engaging in any activity within the purposes for which a limited liability company may be formed under the Limited Liability Company Act of Michigan. You may provide a more specific purpose:

Article III

The duration of the limited liability company if other than perpetual is:

Article IV

The street address of the registered office of the limited liability company and the name of the resident agent at the registered office (P.O. Boxes are not acceptable):

1. Agent Name: JOSEPH CRANMORE
 2. Street Address: 713 BLOOMFIELD BLVD
 Apt/Suite/Other:
 City: JACKSON
 State: MI Zip Code: 49203

3. Registered Office Mailing Address:
 P.O. Box or Street Address: 713 BLOOMFIELD BLVD
 Apt/Suite/Other:
 City: JACKSON
 State: MI Zip Code: 49203

Signed this 22nd Day of February, 2021 by the organizer(s):

Signature	Title	Title if "Other" was selected
Joseph J Cranmore	Organizer	

By selecting ACCEPT, I hereby acknowledge that this electronic document is being signed in accordance with the Act. I further certify that to the best of my knowledge the information provided is true, accurate, and in compliance with the Act.

Decline Accept

MICHIGAN DEPARTMENT OF LICENSING AND REGULATORY AFFAIRS

FILING ENDORSEMENT

This is to Certify that the ARTICLES OF ORGANIZATION

for

FIVE POINT FARMS, LLC

ID Number: 802613150

received by electronic transmission on February 22, 2021 **, is hereby endorsed.**

Filed on March 01, 2021 **, by the Administrator.**

The document is effective on the date filed, unless a subsequent effective date within 90 days after received date is stated in the document.



In testimony whereof, I have hereunto set my hand and affixed the Seal of the Department, in the City of Lansing, this 1st day of March, 2021.

Linda Clegg

Linda Clegg, Director

Corporations, Securities & Commercial Licensing Bureau



Five Point Farms, LLC

Social Equity Plan

As a Social Equity applicant, Five Point Farms understands the importance of the Social Equity program and will strive to hire employees that have been disproportionately affected by marijuana prohibition.

Our goal is to positively affect our local communities by employing a diverse, well trained staff and fostering an inclusive working environment, while giving back to our local communities and organizations.

1. Five Point Farms will invest in their employees by training in all areas of the business, providing them with additional skills and an understanding of how a business operates. These additional skills and an understanding of business processes will make individuals more employable in any industry. Five Point Farms will also encourage, support and assist employees that wish to start their own cannabis related business.
2. Five Point Farms will support and positively impact our local communities that have been negatively impacted by the war on drugs. We will work with local organizations, participate in local events, and provide assistance through donations and the volunteering of our time.

GRETCHEN WHITMER
GOVERNOR



ORLENE HAWKS
DIRECTOR

STATE OF MICHIGAN
DEPARTMENT OF LICENSING AND REGULATORY AFFAIRS
LANSING
VIA ELECTRONIC MAIL

Date: October 27, 2021

Addressee: Five Point Farms, LLC
Address: 713 Bloomfield Blvd.
Jackson, MI 49203

RE: Prequalification status for your pending application

Dear Applicant:

The Marijuana Regulatory Agency (Agency) considered your partial application for prequalification status and determined that you have prequalification status pursuant to the licensing provisions of the Michigan Regulation and Taxation of Marihuana Act (MRTMA) and associated rules. This letter may be provided to a municipality as documentation of your prequalification status. Please note that this is a pending status until all application requirements of the MRTMA and associated rules are completed. A state license for a marihuana establishment cannot be issued at this stage of the application process. During complete application review, the Agency will consider all information relevant to eligibility including information that has been newly acquired or information that is newly apparent since determination of prequalification status.

If you have not already done so, please submit a marijuana establishment license application (Step 2) for each state license for which you wish to apply. You may submit an application online through the Accela Citizen Access Portal on the Agency website at www.michigan.gov/mra or your application may be submitted by mail or in person as follows:

Mailing Address:

Marijuana Regulatory Agency
Licensing Division
Adult-Use
P.O. Box. 30205
Lansing, MI 48909

In Person:

Marijuana Regulatory Agency
Licensing Division
Adult-Use
2407 North Grand River
Lansing, MI 48906

Sincerely,

Licensing Division
Marijuana Regulatory Agency