

# CITY OF JACKSON



## Jackson City Hall Lobby Door Replacement

**Bid Responses Due: Tuesday, June 19, 2018 by 10:00:00 AM**

### CONTENTS

INVITATION FOR BIDS  
INSTRUCTIONS TO BIDDERS (IB)  
PROPOSAL FORMS (P)  
AGREEMENT (A)  
GENERAL CONDITIONS (G)  
DETAILED SPECIFICATIONS

CITY OF JACKSON, MICHIGAN  
161 W. Michigan Avenue  
Jackson, Michigan 49201

May 23, 2018

INVITATION TO BID

Sealed proposals for Jackson City Hall Lobby Door Replacement will be received by the City of Jackson Purchasing Agent, 161 W. Michigan Avenue, 10th Floor, Jackson, Michigan, Tuesday, June 19, 2018 until 10:00:00 AM.

The work includes the following partial listing of items with approximate quantities: Removal and replacement of 3 existing door systems with 3 new door systems. 2 new systems are sliding aluminum storefronts, the third system is a standard aluminum storefront with one power assist door. Scope of work included demolition, new storefronts, electrical and associated paint touch up. See drawings and specifications for further information.

Bidders may obtain packets containing Instructions to Bidders, Proposal Forms, Specifications and Contract Forms at the Purchasing Department, 10th Floor, 161 W. Michigan Avenue, Jackson, Michigan 49201, Telephone (517) 788-4020 or from the city's website at <http://www.cityofjackson.org/rfq>.

Prospective bidders are invited to attend a pre-bid meeting on Tuesday, June 5, 2018 at 10:00 AM, *Purchasing Department, 10th Floor, 161 W. Michigan Avenue, Jackson, MI 49201.*

Any questions concerning contract documents or specifications will be addressed at this meeting. This will give companies contemplating submitting a bid a chance to examine the locations of the proposed service/goods and receive interpretations of the contract documents.

The City of Jackson does not discriminate on the basis of race, religion or national origin, color, age, sex, height, weight, marital status, and physical or mental handicap as to: access, availability, employment, or participation in any of its programs and activities.

City of Jackson  
By  
Phil Hones, Purchasing Agent

# INSTRUCTIONS TO BIDDERS

1. **PROJECT:** The work includes the following partial listing of items with approximate quantities:

*Removal and replacement of 3 existing door systems with 3 new door systems. 2 new systems are sliding aluminum storefronts, the third system is a standard aluminum storefront with one power assist door. Scope of work included demolition, new storefronts, electrical and associated paint touch up. See drawings and specifications for further information.*

The scope of this work shall include all labor, equipment and materials necessary to complete this project according to the specifications listed in the contract documents. All labor, equipment and materials necessary for completion of the work, but not specifically listed as a pay item, will be deemed to be included in one or more of the pay items listed in the bid sheet.

2. **PROPOSALS:**

- a. Proposals are to be submitted on the forms attached. They should be submitted to the Purchasing Agent, City of Jackson, as provided in the Invitation for Bids in a sealed envelope marked "Jackson City Hall Lobby Door Replacement".

- b. Proposals, affidavits, certificates and all appendices must be fully and properly filled out and executed.

- c. Proposals must be bid on a unit price basis as applied to the estimated quantities. Where errors of extension of totals are made, the unit price bid multiplied by the estimated quantity shall govern. The preliminary estimates of quantities indicated, although given with as much accuracy as possible, are to be regarded as approximately only, and are given for the general guidance of the bidders and as a basis upon which the different proposal may be compared. The City reserves the right to increase or diminish any or all of these quantities within reasonable limits and the Contractor will be paid for the actual work completed and accepted by the City at the prices stated in his Proposal.

Upon the discovery of an obvious error in a bid document that could result in a change in the amount of a bid, the staff of the Purchasing Department shall contact the bidder in writing and advise the bidder that it has seven working days from the date of the letter to correct the error. This correction shall be in writing directed to the Purchasing Agent and shall be postmarked not later than seven working days from the date of the letter referred to in the first sentence of this paragraph.

If no correction is received in a timely fashion, then the Purchasing Agent shall reject the bid. If a correction is received and the Purchasing Department deems the same to be appropriate and proper in every way, the Purchasing staff shall attach same to the original bid document and shall then proceed to tabulate the bids as corrected.

d. Proposals may be withdrawn up to the time for opening bids announced in the Invitation for Bids. Proposals shall remain in effect for 60 days after opening.

e. Each bidder shall be held to have examined the site of the proposed work and adjacent areas in order to arrive at a clear understanding of the conditions under which the work is to be done. He shall be held responsible to have compared the site with the drawings and specifications and to have satisfied himself as to the conditions of the site, existing obstructions, the actual elevations, and any other conditions affecting the carrying out of his work. No allowance or extra consideration on behalf of the Contractor shall be allowed by reason of error, negligence, oversight, or carelessness on the part of the Contractor.

f. The City may request of any bidder evidence of experience performing the work being bid, and may require information on financial status and equipment available for the project.

g. Each bidder shall indicate on page 12 of the Proposal Forms the name, address, and a complete description of work to be performed by each subcontractor on this project. All subcontractors must be approved by the City, and must meet the same requirements of the successful bidder.

h. On contracts that have two or more divisions, proposals that offer a percentage deduction if a single bidder is awarded more than one division, will be considered provided that the deduction is clearly identified in the proposal.

3. **BID SECURITY:** All Proposals must be accompanied by a certified check made payable to the order of the City of Jackson in the amount of 5% of the aggregate bid total. Bid bonds with authorized surety companies as sureties and of like amount may be substituted for certified checks at the option of the bidder. Such bid bonds must be run to the City of Jackson, Michigan.

All proposals submitted without bid security will be returned to the bidder unread.

The bid deposit of all except the three (3) lowest bidders will be returned within (3) days after the opening of bids. The bid deposit of the three lowest bidders will be returned within forty-eight (48) hours after Contract and required bonds have been finally approved by the City.

4. **EQUAL EMPLOYMENT OPPORTUNITY:** All bidders shall complete the Equal Employment Opportunity Certification, Certification of Nonsegregated Facilities, and Non-Collusion Affidavit, found in Section P of the Proposal Forms.

5. **AWARD:**

A. If the contract is over \$20,000, then the City Council will be advised of the bids received and receive staff recommendations on award. Award of contract, if any, will be made to the single lowest responsible bidder for the entire scope of the project. Provided however, the City Council has the authority to reject any and all bids, and to accept or recommend the acceptance of other than the lowest responsive bid when the public interest is served thereby and such action is in the best interest of the City.

B. The City Council reserves the right to reject any and all bids and to waive minor irregularities and/or technicalities in the bids.

6. **CONTRACT:**

A. If the awarded contract is \$50,000 or greater, the following bond requirements will apply:

Contractor shall, within ten (10) days of notice of award, provide City at Contractor's expense with three bonds using the forms attached hereto (B-1 through B-7):

(1) A performance bond executed to the City, to be in an amount of one hundred percent (100%) of the full contract price to be conditioned on the faithful performance of the contract and to include the protection of the City from all liens and damages arising out of the work;

(2) A Labor and Material Payment Bond to be executed to the People of the State of Michigan and the City of Jackson, to be in the amount of one hundred percent (100%) of the full contract price, and to be conditioned on the payment of all labor and materials used in the work and for the protection of the City from all liens and damages arising therefrom, as required by Act 213 of the Public Acts of Michigan of 1963, as amended; and

(3) A Maintenance and Guarantee Bond in a minimum amount of twenty five percent (25%) of the contract price.

All bonds shall be signed by the contractor and a surety company licensed to do business in the State of Michigan with sureties acceptable to the City. Said bonds shall be payable to the City of Jackson and filed in the office of the City Clerk.

B. Within 10 days of notification of award, the Contractor must provide certificates of insurance evidencing insurance coverage as required by the Contract.

C. The successful bidder will be required to sign a contract in three counterparts in substantially the form provided with this bid packet. Failure to do so within 10 days of Notification of Award will result in forfeiture of the bid security.

D. The Contractor will be provided with Notification to Proceed upon completion of the steps in this paragraph. The Contractor must begin work within 5 days of the Notice to Proceed.

E. Contract Documents require that all work on this project be completed by six (6) weeks after Notice to Proceed.

**7. PERFORMANCE OF WORK:**

Work performed on this contract shall be completed after 5:00 PM Monday through Friday or on weekends so that City offices are accessible to the public.

# PROPOSAL

TO: City Manager  
c/o Purchasing Agent  
City of Jackson, Michigan

Date: \_\_\_\_\_

In compliance with your invitation for bids dated \_\_\_\_\_  
to perform \_\_\_\_\_  
in the City of Jackson, the undersigned, a(n)

1. individual, resident of \_\_\_\_\_  
doing business as \_\_\_\_\_  
at \_\_\_\_\_
2. partnership, consisting of \_\_\_\_\_  
and \_\_\_\_\_  
under the firm name of \_\_\_\_\_
3. corporation by the name of \_\_\_\_\_  
organized and existing under the laws of the State of \_\_\_\_\_  
with offices at \_\_\_\_\_  
(strike inapplicable clauses)

hereby proposes to perform said work, strictly as specified in the bid documents at the prices set forth on the attached schedule of bid prices, upon receipt of written notice of acceptance of this bid within sixty (60) calendar days after opening of the bids at the time stated in said Invitation; to execute a properly completed contract in the form provided with the bid documents in accordance with this bid; to give bond with good and sufficient surety or sureties, satisfactory to the City Attorney of Jackson, for the faithful performance of said contract, for payment of labor and materials, and, if required, for maintenance of work; and to give such bond within ten (10) days after notice of award.

FEDERAL ID# \_\_\_\_\_

(Corporate Seal, if applicable) Name of Bidder: \_\_\_\_\_

Signed

By: \_\_\_\_\_  
\_\_\_\_\_

Its: \_\_\_\_\_  
\_\_\_\_\_

<b>BID SHEET</b>
------------------

DATE:

**PROPOSAL FOR: Jackson City Hall Lobby Door Replacement**

TO: The Mayor and the City Council  
City of Jackson, Michigan

Ladies and Gentlemen:

The Undersigned has examined the plans, specifications, and the location of the above described work, and is fully informed as to the conditions relating to its performance, and understands the quantities shown in the estimate and on the plans are accurate to the best belief and knowledge of the Engineer, but are not guaranteed.

The undersigned hereby proposes to furnish all equipment, materials, supplies, labor, and services necessary to commence and complete the project as described in the Contract Documents; and in strict conformity with the requirements of the Specifications and such other special provisions and supplemental specifications as may be a part of this proposal for the above described project at the following unit prices all labor, equipment and materials necessary for completion of the work, but not specifically listed as a pay item, will be deemed to be included in one or more of the pay items listed in the bid sheet.

Bidder has examined and carefully studied the Bidding Documents, other related data identified in the Bidding Documents, and the following Addenda, receipt of which is hereby acknowledged (list addenda by Addendum Number and Date):

Addendum No.	Date
_____	_____
_____	_____
_____	_____

<b>SCHEDULE OF BID PRICES</b> <b>NOTE: UNIT PRICES MUST BE LISTED AND SHALL GOVERN.</b>
--

DESCRIPTION	LUMP SUM BID
Lump sum bid for lobby door replacement per specifications	
TOTAL BID WRITTEN OUT:	

Bidders Name:	
---------------	--

Address:	
City, State, Zip:	
Telephone:	
Fax:	
Email Address:	
Federal ID Number:	
Bid Signed By:	Print or Type
Title:	

1. I am the person described in and who executed the foregoing bid and that the several matters stated are in all respects true.
2. That I am an employee of the firm or company described in and I am authorized to submit said bid.

By \_\_\_\_\_ Its \_\_\_\_\_

## CONTRACT COMPLIANCE

DATE: May 23, 2018  
TO: All Bidders  
FROM: City of Jackson  
SUBJECT: CONTRACT COMPLIANCE

The Commission of the City of Jackson, on 12/19/72, passed a resolution committing the City to a policy and procedure regarding compliance to affirmative hiring practices by contracting agencies doing business with the City of Jackson, effective 12/20/72.

The purpose of the policy and procedure is to ensure that all citizens of our community have the opportunity for the equality of treatment in service and employment.

The City requests that all bidders who will be doing business with the City in the amount of \$5,000 or more during any fiscal year, shall comply with the provisions of the Contract Compliance Policy.

Bidders will be required to show an Equal Employment Opportunity Certificate of Compliance or demonstrate compliance with standards for equal employment opportunity established by state and federal statute.

City Council of Jackson, Michigan

**CONTRACT COMPLIANCE**

CERTIFICATION

\_\_\_\_\_ certifies that he/she/it will not discriminate against any employee or applicant for employment with respect to hire, tenure, term, conditions, or privileges or employment because race, religion or national origin, color, age, sex, height, weight, marital status, sexual orientation, gender identity, and physical or mental handicap.

In connection with this commitment \_\_\_\_\_ understands that he/she/it name will be reviewed by the State of Michigan, Department of Civil Rights for determination of its status as an awardable Bidder.

The undersigned hereby agrees that he/she/it will abide by the terms of any agreements made with the City of Jackson in order to achieve awardable status.

Dated: \_\_\_\_\_ By: \_\_\_\_\_  
(Company)

By: \_\_\_\_\_  
(Title)

\_\_\_\_\_  
Address

\_\_\_\_\_  
City

\_\_\_\_\_  
State

## NON-DISCRIMINATION CLAUSE FOR ALL CITY OF JACKSON CONTRACTS

In connection with the performance of this contract, the contractor agrees as follows:

1. The contractor will not discriminate against any employee/employer for employment because of race, religion or national origin, color, age, sex, height, weight, marital status, sexual orientation, gender identity, and physical or mental handicap. The contractor will take affirmative action to ensure that minority applicants are employed, and that employees are treated during employment without regard to their race, religion, color, national origin, age, sex, height, weight, marital status or handicap. Such action shall include, but not be limited to, the following: layoff or termination, rates of pay or other forms of compensation, selection for training, upgrading or promotion, transfer or recruitment.
2. The contractor will, in all solicitations or advertisements for employees placed by or on behalf of the contractor, state that all qualified applicants will receive consideration for employment without regard to race, religion, color, national origin, age, sex, height, weight, marital status or handicap. As a disclaimer, the contractor may state in the advertisement that he/she is an equal opportunity employer.
3. The contractor will furnish and file compliance reports with the City of Jackson as requested. Such reports shall elicit information as to the practices, policies, program and employment statistics for the contractor and said contractor shall permit access to all books, records and accounts regarding employment practices by agents and representatives of the City duly charged with investigative duties to assure compliance with this clause.
4. Breach of the covenants herein may be regarded as a material breach of the contract, or purchasing agreement.
5. The contractor will include, or incorporate by reference, the provisions of paragraphs (1) through (4) in every subcontract or purchase order unless exempted by the rules, regulations or orders of the Michigan Civil Rights Commission and will provide in every subcontract or purchase order that said provisions will be binding upon each subcontractor or seller.

**EQUAL EMPLOYMENT OPPORTUNITY CERTIFICATION**

The undersigned understands and agrees that, as a Contractor for services, there shall be no discrimination against any employee or applicant for employment because of race, religion or national origin, color, age, sex, height, weight, marital status, sexual orientation, gender identity, and physical or mental handicap, including but no limited to employment, upgrading, demotion, or transfer; recruitment or recruitment advertising; layoff or termination; rates of pay or other forms of compensation and selection for training.

The Contractor further agrees to the following:

- (a) It will assist and actively cooperate with the City in obtaining compliance of any subcontractors with the equal opportunity rules, regulations, and relevant orders.
- (2) It will furnish the City such information as might be required for the supervision of its compliance program, and will otherwise assist the City in the discharge of its responsibility for ensuring compliance.
- (3) In the event that the Contractor fails or refuses to comply with the equal opportunity regulations, the City may cause to be canceled, terminated, or suspended in whole or in part the contractual arrangement between the City and the Contractor.

NAME OF BIDDER: \_\_\_\_\_

ADDRESS: \_\_\_\_\_  
\_\_\_\_\_

SIGNED BY: \_\_\_\_\_

TITLE: \_\_\_\_\_

DATE: \_\_\_\_\_

**CERTIFICATION OF NONSEGREGATED FACILITIES**

The bidder certifies that he does not maintain or provide for his employees any segregated facilities and do not permit his employees to perform their services at any location, under his control, where segregated facilities are maintained. The bidder certifies further that he will not maintain or provide for his employees any segregated facilities at any of his establishments, and that he will not permit his employees to perform their services at any location under his control where segregated facilities are maintained. The bidder agrees that a breach of this certification will be a violation of the Equal Opportunity clause in any contract resulting from acceptance of this bid. As used in this certification, the term "segregated facilities" means any waiting rooms, work areas, restrooms and washrooms, restaurants and other eating areas, time clocks, locker rooms and other storage or dressing areas, parking lots, drinking fountains, recreation or entertainment areas, transportation, and housing facilities provided for employees which are segregated by explicit directive or are in fact segregated on the basis of race, color, religion, or national origin, because of habit, local custom, or otherwise. The bidder agrees that (except where he has obtained identical certification from proposed subcontractors for specific time periods) he will obtain identical certification from proposed subcontractors prior to the award of subcontracts exceeding \$10,000 which are not exempt from the provisions of the Equal Opportunity clause, and that he will retain such certifications in his files.

Dated: \_\_\_\_\_ By: \_\_\_\_\_  
(Name of Bidder)

By: \_\_\_\_\_  
(Title)

\_\_\_\_\_  
Address

\_\_\_\_\_  
City

\_\_\_\_\_  
State

**NON-COLLUSION AFFIDAVIT OF PRIME BIDDER**

STATE OF \_\_\_\_\_ )

ss

COUNTY OF \_\_\_\_\_ )

\_\_\_\_\_, being first duly sworn, deposed and says that:

1. He is \_\_\_\_\_ of, \_\_\_\_\_ the Bidder that has submitted the attached bid;
2. He is fully informed respecting the preparation and contents of the attached bid and of all pertinent circumstances respected such bid;
3. Such bid is genuine and is not a collusive or sham bid;
4. Neither the said Bidder nor any of its officers, partners, owners, agents, representatives, employees or parties in interest, including this affiant, has in any way colluded, conspired, connived or agreed, directly or indirectly with any other Bidder, firm or person to submit a collusive or sham bid in connection with the contract for which the attached bid has been submitted or to refrain from bidding in connection with such contract, or has in any manner, directly or indirectly, sought by agreement or collusion or communication or conference with any other Bidder, firm or person to fix the price or prices in the attached bid or of any other Bidder, or to fix any overhead, profit or cost element of the bid price or the bid price of any other Bidder, or to secure through any collusion, conspiracy, connivance or unlawful agreement any advantage against the City of Jackson or any person interested in the proposed contract; and
5. The price or prices quoted in the attached bid are fair and proper and are not tainted by any collusion, conspiracy, connivance or unlawful agreement on the part of the Bidder or any of its agents, representatives, owners, employees, or parties in interest, including this affiant.

Dated: \_\_\_\_\_ By: \_\_\_\_\_  
(Company)

By: \_\_\_\_\_  
(Title)

Subscribed and sworn to before me, a Notary Public, this \_\_\_\_\_ day of \_\_\_\_\_, 20\_\_\_\_.

\_\_\_\_\_  
Notary Public, \_\_\_\_\_ County,  
My commission expires: \_\_\_\_\_



**RIGHT TO KNOW  
CONTRACTOR RELEASE FORM**

I, \_\_\_\_\_ an authorized representative of \_\_\_\_\_ am aware that as a requirement to perform work for the City of Jackson on a contractual basis, I must have provided my employees with the basic training requirements of the HAZARD COMMUNICATION STANDARD as prescribed by the Michigan Right to Know amendments to Act 154 of the Public Acts of 1974 (Act 80, Public Acts 1986), prior to starting any work for the City. While engaged in working for the City, I will continue to comply with Michigan Right to Know Law until completion of the contract.

I am aware that if I bring any hazardous chemical to the City's work place, I must have available the MSDS for these chemicals, in a place accessible to all employees in the work place. If necessary, due to the "special protection information" requirement stated on the MSDS for the chemicals, I will provide all employees with any special training, special protective clothing or equipment necessary to eliminate or lessen the possible exposure to the hazardous chemical or chemicals.

By execution of this Release, the contractor acknowledges that he and all subcontractors and suppliers, will comply with all requirements of the HAZARD COMMUNICATION STANDARD. Further, the contractor shall hold harmless from and indemnify the City against all claims, suits, actions, costs, counsel fees, expenses, damages, judgements or decrees, by reason of his failure, or the failure of any subcontractor, suppliers, or any person employed under said contractor to comply with the requirements of Act 154 of the Public Acts of 1974 as amended.

Dated \_\_\_\_\_

\_\_\_\_\_  
Signature



# City of Jackson Ethics Disclosure Form Vendors and Contractors

Name	Company
Telephone	Email Address

Contract or matter pending with the City:

---



---

I, \_\_\_\_\_, being duly sworn, and pursuant to City of Jackson Ordinance No. 2015-18, I hereby disclose and swear to the following (check all that apply and provide details below):

- I, or my company’s owners, members, major shareholders, or corporate officers, have a financial interest in a contract or matter pending before Jackson City Council.
- A relative<sup>1</sup> or immediate family member<sup>2</sup> of myself or my company’s owners, members, major shareholders, or corporate officers has a financial interest in a contract or matter pending before a City office, department, board, or commission.
- I, or my company’s owners, members, major shareholders, or corporate officers, have an interest in real or personal property that is subject to a decision by the City regarding the purchase, sale, lease, zoning, property improvements, NOORPR or FVA registration, a development agreement, or a special tax designation or abatement.

Property address: \_\_\_\_\_

Property interest: \_\_\_\_\_

- An immediate family member or relative of myself or my company’s owners, members, major shareholders, or corporate officers, has a financial interest in real or personal property that is subject to a decision by the City

<sup>1</sup> Relative means any spouse, domestic partner, great grandparents, step great grandparents, grandparents, step grandparents, sons, stepsons, daughters, step daughters, grandsons, step grandsons, granddaughters, step granddaughters, brothers, step brothers, sisters, step sisters, and in-laws of a Public Employee, the Mayor, an Elected Official, an Appointed Official, a member of a Board or Commission, a Contractor, or an Advisor of the City.

<sup>2</sup> Immediate family member means a Public Employee, the Mayor, an Elected Official, an Appointed Official, a member of a Board or Commission, a Contractor, or an Advisor’s spouse, domestic partner, individual who lives in the Public Employee’s household or an individual claimed by a Public Employee or a Public Employee’s spouse as a dependent under the United States Internal Revenue Code at 26 USC 1, et seq.

regarding the purchase, sale, lease, zoning, property improvements, NOORPR or FVA registration, a development agreement, or a special tax designation or abatement.

Property address: \_\_\_\_\_

Property interest: \_\_\_\_\_

An immediate family member or relative of myself or my company's owners, members, major shareholders, or corporate officers, is employed by the City or making an application for employment to the City.

Relative name: \_\_\_\_\_

City Department: \_\_\_\_\_

I, or my company's owners, members, major shareholders, or corporate officers, have made campaign contributions in the last year to a candidate running for elective office with the City.

Name of Candidate: \_\_\_\_\_

Amount of Campaign Contribution: \_\_\_\_\_

The following entities and persons have a financial interest in the contract or matter identified above:

\_\_\_\_\_  
\_\_\_\_\_  
\_\_\_\_\_

Additional information regarding any of the above:

\_\_\_\_\_  
\_\_\_\_\_  
\_\_\_\_\_

None of the above apply.

Dated: \_\_\_\_\_  
*Signature*

STATE OF MICHIGAN     )  
                                  ) SS  
COUNTY OF JACKSON    )

The foregoing instrument was acknowledged before me this \_\_\_\_\_ day of \_\_\_\_\_, 20\_\_\_\_,  
By \_\_\_\_\_.

\_\_\_\_\_

# AGREEMENT

THIS AGREEMENT, made and entered into this \_\_\_ day of \_\_\_\_\_, 2018, by and between the City of Jackson, Michigan, a Michigan municipal corporation, herein "the City", and whose address is \_\_\_\_\_ herein "the Contractor".

WITNESSETH:

WHEREAS, the City deems it necessary to undertake the herein described Project; and

WHEREAS, the City has advertised for sealed proposals for said Project; and

WHEREAS, the Contractor submitted a proposal for said Project which was accepted by the City as the lowest responsible bid, and

WHEREAS, the City has in all other respects complied with requirements for entering into this Agreement; and

WHEREAS, the persons executing this Agreement are duly authorized by the respective parties;

NOW, THEREFORE, for, and in consideration of, the recited promises and the mutual covenants and agreements herein contained, the parties hereto agree as follows:

- I. A. Contractor agrees to provide all equipment, material, supplies, labor and services necessary to commence and complete the project as described in the Contract Documents; and
- B. Contractor agrees to perform all work described in the Contract Documents in a substantial and workmanlike manner, and to comply with all the requirements in the Contract Documents at the unit prices' bid for the total sum of
- C. Contractor agrees to commence work within five (5) days from Notice to Proceed and to complete all work within the time limit as listed in the Instructions to Bidders.
- II. The City agrees to pay the Contractor in the manner, and at such times, as set forth in the Contract Documents.
- III. This Agreement includes of all the Contract Documents listed in the General Conditions, which are fully incorporated by reference whether attached or not.
- IV. Contractor covenants and agrees that it will be bound by the terms of the attached Equal Employment Opportunity Clause.

- V. This Agreement is binding on the parties hereto, and their respective heirs, personal representatives, and assigns.
- VI. The provisions of the City of Jackson's Purchasing Manual as last amended shall, where applicable, be binding on all transactions.

IN WITNESS WHEREOF, the parties hereto have executed, or caused to be executed by their duly authorized officials, this Agreement in three (3) counterparts, each of which shall be deemed an original, the day and year above written.

CITY OF JACKSON, MICHIGAN  
a Municipal Corporation

\_\_\_\_\_  
Witness By Derek Dobies, Mayor

\_\_\_\_\_  
Witness By Andrea Muray, City Clerk  
\* \* \* \*

\_\_\_\_\_  
Witness By  
Company Name  
Signature

\_\_\_\_\_  
Please print or type name

\_\_\_\_\_  
Title

\_\_\_\_\_  
APPROVED AS TO SUBSTANCE:

\_\_\_\_\_  
APPROVED AS TO FORM:

\_\_\_\_\_  
Patrick Burtch  
**City Manager**

\_\_\_\_\_  
Bethany M. Smith  
**City Attorney**

# GENERAL CONDITIONS

I. **DEFINITION OF TERMS USED:** The terms used in the Contract Documents are defined as follows:

A. "City" shall mean the City of Jackson, Michigan, a municipal corporation or the City department responsible for overseeing the performance of the work.

B. "Contract Documents" shall include the following:

Invitation for Bids	Bid Bond
Instructions to Bidders	Notice of Award
Addendums to Instructions to Bidder	Performance Bond
Payment Bond	Agreement
Insurance Certificate	Authorized Change Orders
Notice to Proceed	Specifications
General Conditions	Special Provisions
Plans and Drawings	Supplemental Specifications
Maintenance Bond	
Bid Proposal and Bid Sheet(s), including all attachments	
All other documents attached hereto	

C. "Contractor" shall mean the person or persons, firm partnership, company or corporation who has contracted for the completion of the work specified in the contract documents.

D. "Work" shall mean the services to be performed by the Contractor as set forth in these contract documents.

II. **CONTRACTOR'S OBLIGATIONS:**

A. **Schedule of Work:** The Contractor shall prior to start of construction, submit to the City for written approval a practicable and feasible schedule, showing the order in which he proposes to carry on the work. The schedule shall be in the form of a progress chart of suitable scale to indicate approximately the percentage of work scheduled for completion at any time. The schedule shall not exceed time limits required by the contract documents. The Contractor shall perform the work in accordance with the schedule. The schedule may only be revised with the written approval of the City.

B. **Drawings and Specifications:** The drawings and specifications are so drafted as to indicate the conditions existing to the best knowledge and belief of the City, but are not guaranteed 100 percent accurate. Should any inconsistency or error appear or occur in the drawings and/or specifications, the Contractor shall report it to the City and obtain proper adjustments before proceeding with the work. In the case where soil borings have been made, and logs thereof are recorded, the information is offered to the Contractor merely as evidence and the Contractor himself must assume entire responsibility for any conclusions which he may draw from it.

C. **Performance and Completion of Work:** Contractor shall provide all labor, materials, tools, and equipment for proper execution and completion of work in accordance with

contract documents, and shall complete and deliver work to the City on schedule within the specified time. The Contractor shall furnish sufficient forces, construction plant and equipment as may be necessary to insure the progress of the work in accordance with the approved progress schedule. If, to maintain satisfactory progress, it is necessary to increase the work force or to work overtime, or to increase machinery, equipment or staging on site, such additional work, machinery, equipment, and staging shall be provided by the Contractor without additional cost to the City.

Failure of the Contractor to comply with the requirements of the Contract under this provision will be grounds for determination by the City that the contractor is not pursuing the work with such diligence as will insure completion within the specified time limits. Upon such determination by the city, it may terminate the contractor's right to proceed with the work, in accordance with the provisions governing Termination of Contract in these General Conditions.

- D. **Materials and Workmanship:** All materials shall meet the requirements of the applicable specifications and shall be installed or used in accordance with the directions of the manufacturer and in such a manner so as to preserve all manufacturer warranties. All work shall be done in a good, substantial, workmanlike manner, by skilled workmen. The Contractor shall assign to the City before final payment all manufacturer's warranties relating to the materials, labor, or equipment used in the work.
- E. **Superintendence by Contractor:** The Contractor shall give his personal superintendence to the work or have a competent foreman or superintendent, satisfactory to the City, in attendance at the site at all times during performance of the work, with authority to act for him and all communications given to the foreman or superintendent shall be as binding as if given to the Contractor. The Contractor shall also be responsible for the general supervision and coordination of work among the various subcontractors.
- F. **Permits, Fees, and Notices:** The Contractor shall secure and pay for the building permit, if required, and all other permits and governmental fees, licenses and inspections necessary for proper execution and completion of the Work.

The Contractor shall comply with and give notices required by laws, ordinances, rules, regulation and lawful orders of public authorities having jurisdiction over Work, as determined by the City.

All work shall comply with all requirements of all current ordinances, laws and regulations of all federal, state and local authorities having jurisdiction. The contractor shall be responsible for requesting, obtaining and paying for inspections of his work as required by said authorities.

If the Contractor observes that portions of the Contract Documents are at variance with applicable laws, statutes, ordinances, building codes, and rules and regulation, the Contractor shall promptly notify the City in writing, and necessary changes shall be accomplished by appropriate modification. If the Contractor performs Work contrary to laws, statutes, ordinances, building codes, rules and regulations, or lawful orders of public authorities, without such notice to the City, the Contractor shall assume full responsibility for such Work, its correction or removal, and shall bear the attributable costs.

- G. **Protection of Property and Structures:** The Contractor shall carefully protect the property of the City, adjacent properties and structures, and utilities both above and below the surface of the ground. All damages to property, existing structures, trees and shrubs will be remedied by the Contractor by repairing, restoring or replacing the same to its prior condition as incidental to the work, and no extra compensation will be allowed.
- H. **Protection and Preservation of Land Monuments and Property Line Marks:** The Contractor shall protect carefully from disturbance or damage, all land monuments and iron pins or other markers which establish property or street lines, provided that where such monuments or marker must, of necessity, be disturbed or removed in the performance of the contract, the Contractor shall first give ample notice to the Engineer, so that he may witness or reference in such monuments or markers. Should the Contractor disturb, remove or damage any established land monument or property or street line mark without first giving the Engineer ample notice, the Engineer may, at his option, deduct the cost of reestablishing such monuments or markers from any monies due or to become due the Contractor.
- I. **Safeguards:** The Contractor shall at all times take every precaution to safeguard both employees and the public from hazards incidental to the work, and shall comply with all applicable provision of Federal, state and Municipal Safety Laws and Codes. When required, safeguards shall include watchmen, traffic signalmen, railing, barricades and lights employed in such a manner as to afford maximum safety.
- J. **Use of Premises:** The Contractor shall confine his apparatus, the storage of materials, and the operation of his workers to limits indicated by law, ordinance, permits, or direction of the City, and shall not unreasonably encumber the premises or streets with his equipment or materials. The Contractor shall ensure that the site is maintained in a safe condition and kept orderly and clean and all combustible rubbish shall be promptly removed from the site. He shall further make every effort to maintain uncongested vehicular and pedestrian access to the site and all adjacent areas at all times. Whenever it becomes necessary to close off a street, permission of the City Engineer must be obtained. The Police Department, Fire Department, City Engineer, and local residents shall be notified forty-eight (48) hours in advance of each closing by the Contractor. The Contractor shall not erect any sign on the site without the City's prior written consent.
- K. **Cleanup of Temporary Storage Site:** At the completion of the work, the Contractor shall remove all rubbish, tools, equipment, temporary work and surplus materials from the temporary storage site and adjacent premises. If the Contractor does not attend to such cleaning as above stipulated when so requested by the City, the City may cause such cleaning to be done by others and charge the cost thereof to the Contractor. No portion of the work can be abandoned before the cleanup is completed, nor shall final payment be made prior to complete cleanup and acceptance by the City Manager.
- L. **Water for Construction Use:** If the Contractor intends to use water from the City system, he shall make application to the City Water Department, and pay all charges that may be imposed by the Water Department. Adequate precaution shall be taken by the Contractor against freezing or waste of water. All use of any of the City fire hydrants shall be done in accordance with the requirements of the city Water Department, and every effort will be made by the Contractor to use these hydrants in

such a manner as not to interfere with the operation of the City Fire Department. The cost, charges and fees for any such water usage shall be borne by the Contractor.

III. **INSPECTION:**

The City and its employees, agents or representatives shall at all times have access to the work whenever it is in preparation or in progress, and the Contractor shall provide proper facilities for such access and inspection.

The City shall have the right to reject materials and workmanship which are defective or do not comply with contract documents. Rejected workmanship shall be satisfactorily corrected and rejected materials shall be removed from the premises without charge to the City. If the Contractor fails to correct such defective work or remove rejected materials within a reasonable time, the City may remove them and charge the expense to the Contractor.

IV. **PAYMENT:**

A. **Partial Payments:** The City shall make partial payments as the work progresses, as follows:

Upon itemized application by the Contractor and reasonable opportunity for inspection by the City, the City shall make monthly payments to the Contractor based on ninety percent (90%) of the value of the labor and materials incorporated in the work up to the first day of the month less the aggregate of all previous payments, provided that the aggregate of all monthly payments shall not exceed ninety percent (90%) of the contract price.

After the work is 50% in place, additional retainage shall not be withheld unless the City determines, in its sole reasonable discretion, that the Contractor is not making satisfactory progress, or for other specific cause relating to the Contractor's performance under the Contract. If the City so determines, the City may retain not more than 10% of the dollar value of work more than 50% in place. In no case shall the aggregate of all monthly payments exceed 95% of the dollar value of the work.

B. **Final Payment:** Upon completion and acceptance by the City of all work required hereunder, and after the Contractor shall have furnished the City with release of all claims against the City which arise or may arise under and by virtue of this contract, then the City shall pay the balance due under this contract.

Payments otherwise due may be withheld by the City on account of defective work not remedied, rejected work, claims filed, or reasonable evidence indicating probable filing of claims, failure of Contractor to make payments properly to sub-contractors, or for material or labor, or a reasonable doubt that the contract can be completed for the balance then unpaid. If the same are not remedied upon written notice, the City may do so at the Contractor's expense and deduct any sums expended from payments otherwise due.

C. **Deductions.** Pursuant to charter section 2.15, the City may deduct from the amount due to the Contractor any invoices, judgments, or taxes currently owed by the Contractor to the City that are delinquent.

- D. **Acceptance as Release:** Contractor's acceptance of final payment shall be a release to the City of any and all claims of any nature Contractor may assert against City arising out of or relating to this work.

V. **CHANGES TO THIS CONTRACT:**

- A. **Change Orders:** The City shall have the authority to order changes in the work through additions, deletions, or substitutions. Modifications, deletions or additions that change the scope of the work as designated by the contract plans, and extensions of time to complete the contract, shall be covered by a written order signed by the authorized representatives of the Contractor and the City. The change order shall include any change to the contract sum which shall be adjusted in accordance with unit prices and/or lump sum prices as bid.
- B. **Extra Work:** Being defined as work for which unit prices are not listed. Compensation for such extra work shall be included in any change order and shall be based on the actual cost to the Contractor for labor, materials and equipment plus fifteen (15%) percent. The Contractor shall perform such extra work as may be ordered by the City Manager. Any extra work required in an emergency to protect life and property shall be performed by the Contractor as is necessary. The City shall be notified within 48 hours of start of any extra work, for which the Contractor shall keep a strict account of actual cost, and a written work order shall be made out as soon as practical to do so. "Extra work" submitted after the 48-hour limitation will not be reimbursed by the City.
- C. **Delays:** Time is of the essence of this contract. Delays shall be separated into two (2) classifications as determined by the City Manager. The classifications are as follows:
1. delays for which the Contractor is responsible, and
  2. delays caused by Acts of God, riots, strikes, shortages of materials which could not be avoided by reasonable foresight, national emergencies which might create delays, public utility delays, etc.

No extensions of time will be given for delays as in classification (1) above for which the Contractor is responsible.

Delays failing into classification (2) above shall in no way affect the validity of the Contract, but the time limitation of the Contract shall be extended by the same amount of time as such delay may cause to be lost. The Contractor must notify the City in writing within 48 hours of the start of any delays falling into this classification.

- D. **Liquidated Damages:** Should the work under these specifications not be finished within the time specified for any reason other than delays in classification C(2) above, it is agreed that there may be deducted by the City from the final payment to the Contractor a sum computed at the rate of one hundred dollars (\$100.00) per day, beginning the day following the scheduled date of completion and continuing until the date of final acceptance of the work.

It is understood that the above deduction of one hundred dollars (\$100.00) per day is not a penalty, but money due, to be treated as liquidated damages to reimburse the City for the extra costs due to the delay in the completion of the work.

VI. **VOIDABLE AND RESCINDABLE FOR FAILURE TO DISCLOSE CITY EMPLOYEE AS PARTY TO CONTRACT.**

This contract or agreement shall be voidable or rescindable at the discretion of the City at any time if a City employee who is a party to this contract or agreement or has a financial interest in this contract or agreement fails to disclose his or her interest as required by the City of Jackson Code of Ordinances (“the Code”). This contract or agreement is also voidable or rescindable at the discretion of the City at any time if a lobbyist for the Contractor (as defined in Section 2-555 of the Code), or an agent of the Contractor, offers a gift, gratuity, honoraria or payment that is prohibited by the Code to a City employee, the Mayor, an Elected Official, an Appointed Official, or a member of a board or commission of the City.

VII. **TERMINATION BY THE CITY:**

Should the Contractor, at any time, refuse or fail to prosecute the work with promptness and diligence, or in accordance with the contract documents, the City may, at its sole discretion, terminate the contractor's right to proceed with the work by written notice to the Contractor. In such event, the City may enter upon the premises and for the purpose of completing the work included under the contract, take possession of all suitable materials thereon and finish the work by whatever method it deems expedient. In such case the Contractor shall not be entitled to receive any further payment until the work is finished. If the unpaid balance of the contract price exceeds the expense of finishing work, including compensation for additional managerial and administrative services, such excess shall be paid to the Contractor. If such expense shall exceed the unpaid balance, the Contractor and his sureties shall be liable for and shall pay the difference to the City.

VIII. **SECURITY:**

A. **Bonds:** If the awarded contract is \$50,000 or greater, the following bond requirements will apply:

Contractor shall, within ten (10) days of notice of award, provide City at Contractor's expense with three bonds using the forms attached hereto (B-1 through B-7):

- (1) A performance bond executed to the City, to be in an amount of one hundred percent (100%) of the full contract price to be conditioned on the faithful performance of the contract and to include the protection of the City from all liens and damages arising out of the work;
- (2) A Labor and Material Payment Bond to be executed to the People of the State of Michigan and the City of Jackson, to be in the amount of one hundred percent (100%) of the full contract price, and to be conditioned on the payment of all labor and materials used in the work and for the protection of the City from all liens and damages arising therefrom, as required by Act 213 of the Public Acts of Michigan of 1963, as amended; and

- (3) A Maintenance and Guarantee Bond in a minimum amount of twenty five percent (25%) of the contract price.

All bonds shall be signed by the contractor and a surety company licensed to do business in the State of Michigan with sureties acceptable to the City. Said bonds shall be payable to the City of Jackson and filed in the office of the City Clerk prior to the commencement of any Work.

- B. **Insurance**: The Contractor will be required to show evidence of automobile and commercial general liability insurance, worker's compensation insurance and professional liability insurance (where applicable), which is acceptable to the City. The commercial general liability insurance policies shall name the City, its agents, representatives, officers and employees as additional insureds to protect their interests. Both bodily injury and property damage insurance must be on an occurrence basis; and said policies shall provide that the coverage afforded thereby shall be primary coverage to the full limits of liability stated in the declarations, and if said City, agents, representatives, officers or employees have other insurance against the loss covered by said policies, that other insurance shall be excess insurance only. The Contractor shall secure and maintain during the progress of the work such insurance from financially responsible insurance companies having an AM Best rating of A- or better, licensed in the State of Michigan, and approved by the City, that will protect the Contractor, its sub-contractors, and the City from claims for bodily injury, death, or property damage which may arise from performance of the contract. The Contractor shall at the time of execution of the contract file with the City certificate(s) of insurance, which shall cover all of the insurance as required herein. The certificates shall reference the project or contract to which they apply. Upon request by the City, the Contractor shall submit all insurance policies for review. Contractor shall also cause each subcontractor employed by Contractor to purchase and maintain insurance of the types specified below, unless otherwise agreed to by the City in writing. When requested by Owner, Contractor shall furnish copies of certificates of insurance evidencing coverage for each subcontractor. The amounts and types of such insurance shall be not less than the following:

1. Minimum required limits of liability:

- (A) For jobs with an estimated contract cost of less than \$50,000

(1) Comprehensive Commercial General Liability, limits of at least:

- |    |   |           |
|----|---|-----------|
| a. | Bodily Injury, each occurrence                          | \$300,000 |
| b. | Bodily Injury, each aggregate                           | \$500,000 |
| c. | Property Damage, each occurrence                        | \$100,000 |
| d. | Property Damage, aggregate                              | \$100,000 |
|    | (or in the alternative to a, b, c, d)                   |           |
| e. | Bodily Injury and Property Damage Combined Single Limit |           |
|    | each occurrence   | \$500,000 |
|    | and aggregate   | \$500,000 |

(2) Automobile Liability Limits of at least:

- |    |                            |           |
|----|----------------------------|-----------|
| a. | Bodily Injury, each person | \$300,000 |
|----|----------------------------|-----------|

- b. Bodily Injury, each occurrence \$500,000
- c. Property Damage, each occurrence \$100,000  
(or in the alternative to a, b, c)
- d. Bodily Injury and Property Damage Combined Single Limit each occurrence \$500,000

(B) For jobs with an estimated contract cost of \$50,000 or greater and smaller jobs deemed to be dangerous in nature which shall include, but not necessarily limited to, demolition, blasting, excavating and tunneling or other underground work.

(1) Comprehensive Commercial General Liability of at least:

- a. Bodily Injury, each occurrence \$1,000,000
- b. Bodily Injury, aggregate \$1,000,000
- c. Property Damage, each occurrence \$500,000
- d. Property Damage, aggregate \$500,000  
(or in the alternative to a, b, c, d)
- e. Bodily Injury and Property Damage Combined Single Limit  
each occurrence \$1,000,000  
and aggregate \$1,000,000

(2) Automotive Liability and Property Damage Insurance with limits of at least:

- a. Bodily Injury, each person \$1,000,000
- b. Bodily Injury, each occurrence \$1,000,000
- c. Property Damage, each occurrence \$1,000,000  
(or in the alternative to a, b, c)
- d. Bodily Injury and Property Damage Combined Single Limit  
each occurrence \$1,000,000

NOTE: To comply with the required limits of liability, each insurance may be placed in more than one policy, including an excess umbrella type policy.

2. Worker's Compensation and Employer's Liability Insurance as required by the State of Michigan for all Contractor's employees and those of its sub-contractors engaged in work under this contract. If Contractor is a sole proprietorship and as such is not eligible for Worker's Compensation Coverage, Contractor must submit proof of same, satisfactory to the City. **If Contractor is otherwise not obligated to carry Worker's Compensation Coverage, Contractor must submit documentation from the Michigan Department of Labor (Form WC-337 or its equivalent); and**

3. **If the contract requires any work procedures involving explosives, blasting, demolition, excavating, trenching, tunneling, underground work, or other dangerous activity as determined by the City, the property damage liability coverage shall include standard explosion, collapse and underground coverage (XCU) for property damage and bodily injury liability coverage with limits of \$1,000,000 each occurrence and \$1,000,000**

**aggregate; additionally, Contractor shall provide third party pollution liability insurance coverage with minimum limits of \$1,000,000 per occurrence and \$1,000,000 aggregate. The insurance shall name the City and its officers, employees, agents and representatives as an additional insured party.**

4. Each policy shall provide for thirty (30) days written notice of cancellation, expiration, termination, or change of policy to the City. The Contractor shall submit evidence of the coverage, to the City for review and approval. The City will, in writing, identify the policies and indicate its approval or disapproval. New policies shall be provided to the City in place of all policies disapproved. Insurances which expire before Contractor's work is accepted by the City shall be renewed and evidence of such renewal shall be submitted to the City for approval.
5. The Contractor shall advise all insurance companies to familiarize themselves with all of the conditions and provisions of the contract, and insurance companies shall waive the right to special notification for any change or modification of the contract, extension of time, decreased or increased work, cancellation or of any other act or acts by the City or its authorized employees or agents pertaining to the contract. Failure to so notify the aforesaid insurance companies of such changes shall in no way relieve the insurance companies of its obligation under the contract.
6. Nothing contained in these insurance requirements is to be construed as limiting the extent of the Contractor's responsibility for payment of damages resulting from its operations under this contract.
7. If the contract involves new construction, Contractor shall purchase and maintain an Owner's and Contractor's Protective Liability insurance policy and property insurance upon the Work at the site in the amount of the full replacement cost thereof. The insurance shall include the interests of the City, Contractor, Subcontractors, and if applicable, Engineer, Engineer's Consultant, each of whom is deemed to have an insurable interest and shall be listed as an insured or additional insured;

Be written on a Builder's Risk "all-risk" or open peril or special causes of loss policy form that shall at least include insurance for physical loss and damage to the Work, temporary buildings, falsework, and Work in transit and shall insure against at least the following perils: fire, lightning, extended coverage, theft, vandalism and malicious mischief, earthquake, collapse, debris removal, demolition occasioned by enforcement of Laws and Regulations, water damage, and such other perils or causes of loss as may be specifically required by supplementary conditions. The form of policy for this coverage shall be Completed Value.

Include expenses incurred in the repair or replacement of any insured property (including but not limited to fees and charges of engineers and architects);

Cover materials and equipment in transit for incorporation in the Work or stored at the site or at another location that was agreed to in writing by City prior to being incorporated in the Work; and,

Be maintained in effect until payment is made unless otherwise agreed to in writing by City and Contractor with 30 days written notice to each other additional insured to whom a certificate of insurance has been issued.

The policies of insurance required to be purchased and maintained by Contractor in accordance with this paragraph must be approved by City prior to commencement of construction.

- C. **Indemnification:** To the fullest extent allowed by law, the Contractor shall indemnify, defend, and save the City of Jackson, its agents, servants, officials, officers, employees, or representatives (hereinafter "the Indemnitees"), harmless from and against all costs, losses, claims, demands, suits, actions, payments, judgments, or expenses, legal expenses including attorneys' fees, or otherwise, which may occur, arise, or alleged to have occurred or arose from personal injuries, property damage, bodily injury, including death, or otherwise, brought or recovered against the Indemnitees by reason of any act or omission, without limitation or exception, of the Indemnitees, the Contractor, its agents, contractors, subcontractors, servants, employees, or representatives, in the course of, or arising out of, the performance, execution or guarding of all work or services relating to this contract. However, this provision does not indemnify, for the negligence of the Indemnitees, in those situations described in Act 165 of the Public Acts of Michigan of 1966, as amended.
- D. **Liens:** Neither the final payment nor the remaining retained percentage shall become due until the Contractor submits to the City (1) an affidavit that all payrolls, bills for materials and equipment, and other indebtedness connected with the Work for which the City or its property might in any way be responsible, have been paid or otherwise satisfied, (2) consent of surety, if any, to final payment and (3), if required by the City, other data establishing payment or satisfaction of all such obligations, such as receipts, releases and waivers of liens arising out of the Contract, to the extent and in such form as may be designated by the City. If any lien or claim remains unsatisfied after all payments are made, the Contractor shall refund to the City all moneys that the latter may be compelled to pay in discharging such lien or claim, including all costs and reasonable attorneys' fees.
- E. **Guarantee:** The Contractor shall guarantee all materials and work performed under this Contract for the period of one year from the date final payment is made. The contractor shall promptly make any corrections made necessary for reason of faulty materials or workmanship, including corrections of damage to other City property resulting thereby, without cost to the City.

If the award of contract is \$50,000 or greater, the contractor shall provide a Maintenance and Guarantee Bond for a minimum of 25 percent of the total value of the contract price. The Maintenance and Guarantee Bonds shall guarantee the maintenance of all work under this contract for a period of one year from the date of final payment. All bonds shall be signed by the contractor with a surety company licensed to do business in the State of Michigan which is acceptable to the City. Said bond shall be payable to the City of Jackson and filed in the office of the City Clerk.

IX. **ARBITRATION:**

- A. **General:** At the City's option, all claims, disputes or questions arising out of or relating to these contract documents may be referred to arbitration for decision and award.
- B. **Selection:** If the City elects to utilize arbitration, the parties may agree on one arbitrator; otherwise a list of three (3) names shall be requested from the American Arbitration Association. Each party shall eliminate one (1) name from the list. After elimination, the one (1) name remaining, shall be the arbitrator who shall determine the dispute and/or award. If both parties eliminate the same name, then the remaining list of two (2) names shall be sent to the American Arbitration Association with a request to have them decide which arbitrator shall hear the case. Certified copies of the findings and/or award shall be filed with the City and the Contractor.
- C. **Compensation:** The arbitrator shall make such rules as he or she shall determine equitable to govern the conduct of the investigation and determination of the award. The arbitrator shall fix the amount of the cost of the proceedings, including his or her fair and reasonable compensation and shall determine how the total cost shall be borne. All proceedings shall be pursuant to the American Arbitrator's Association rules.
- D. **Work to Continue:** The Contractor will carry on the work during the time any arbitration is proceeding, unless agreed in writing by both parties that other arrangements shall be made.

X. **MISCELLANEOUS:**

- A. **Subcontracts:** The Contractor agrees to be fully responsible to the City for the acts or omissions of his subcontractors and any one employed directly or indirectly by him or them and this contract obligation shall be in addition to the liability imposed by law upon the Contractor.
- B. **Taxes:** The Contractor shall include and be deemed to have included in his bid and contract price all Michigan sales and use taxes currently imposed by legislative enactment and as administered by the Michigan Department of Treasury on the bid date.

If the Contractor is not required to pay or bear the burden, or obtains a refund or drawback in the whole or in part of any Michigan sales or use tax, interest or penalty thereon, which was required to be and was deemed to have been included in the bid and contract price, the contract price shall be reduced by the amount thereof and the amount of such reduction, whether as a refund or otherwise, shall insure solely to the benefit of the City of Jackson.

- C. **Assignments:** The Contractor shall not assign this contract nor any monies to become due thereunder without the prior written consent of the City.
- D. **Social Security:** The Contractor shall pay the contributions measured by wages of his employees required by the Social Security Act and/or the Public Acts of the State of Michigan, and shall accept exclusive liability for said contributions both on account of employees carried directly on his payrolls and for those of his sub-contractors. The Contractor shall further indemnify and hold harmless the City on account of any contributions measured by the wages of employees of the Contractor or any sub-

contractor which may be assessed against the City under authority of said Act of State Law of Michigan.

E. **Patents:** The Contractor shall defend all suits or claims and shall save the City harmless for liability of any nature or kind, including costs and expenses for or on account of any patented invention, article, or appliance, manufactured or used in the performance of this contract.

F. **Testing and Laboratory Service:** All field and laboratory inspection and testing of materials prior to use will be provided for the City under a separate contract or arrangement. The manner and extent of such service, and the selection of the testing agencies, shall be established by the City.

Whenever such prior testing of materials shall indicate that such material does not meet specifications, the Contractor may, at his own expense, make appropriate tests to prove otherwise. Final decision on acceptance or rejection of these materials shall be made by the City.

G. **Interpretation of Contract Documents:** If any doubt exists in the mind of the Contractor as to the correct meaning of any part of the drawings, specifications, or contract documents, he may submit a written request to the City for any interpretation of the intended meaning, and in so doing he must assume the responsibility for its delivery to the City.

In case of any discrepancy in the contract documents, the matter shall be immediately submitted to the City, without whose decision, said discrepancy shall not be adjusted by the Contractor, save only at his own risk and expense.

H. **Access:** The Contractor shall provide the City, the Department of Labor, or any authorized representative thereof; with access to any books, documents, papers, and records of the Contractor which are pertinent to this project for the purpose of making audit, examination, excerpts and transcriptions.

I. **Payment for Idled Persons and Equipment:** In the event that machinery or equipment is idle due to failure of the City to properly provide for the Contractor to proceed with the work in accordance with the contract, or due to a delay caused by a public utility, payment may be allowed in accordance with Section 109.05 of the MDOT Standard Specifications for Highway Construction. If, in the opinion of the Engineer, there are other operations which could be undertaken by the Contractor should he claim idle time, the Contractor shall immediately proceed with such work and no idle time compensation will be approved.

J. **Measurement and Payment.** In the event the contract involves unit bid pricing, such pricing shall govern over total dollar amounts. Quantities of work completed under the contract shall be determined by the city using the standards or methods of measurement provided in the Specifications, Special Provisions, Supplemental Specifications, or any other provision contained in the contract documents. Every attempt shall be made to measure quantity of work as fairly and accurately as possible; however, in the event of a discrepancy or dispute between the Contractor and the City, the City reserves the right to make final determination of the quantities of work completed in order to calculate the total cost of the work (Total contract amount).

K. **Coordination of Plans and Specifications:** In case of discrepancy, figured dimensions shall govern over scaled dimensions and the parts of the contract will prevail over all other parts in the following order.

1. Special Provisions/Conditions
2. Supplemental/Technical Specifications
3. Project Plans and Drawings
4. General Conditions

The Contractor shall not take advantage of any apparent error or omission in the plans, specifications, or other contract documents and if any inconsistency, omission, or conflict is discovered in the plans, specifications, or other contract documents, the Contractor shall (i) provide the better quality or greater quantity of work, or (ii) comply with the more stringent requirements, either or both in accordance with the City's interpretation as to the true intent. If in any place the meaning of the plans, specification, or other contract documents is obscured or uncertain or in dispute, the Contractor shall immediately consult with the City for the City's interpretation as to the true intent.

L. **Fines and Penalties.** Any fines, penalties or other monetary sanctions from any federal or state authority against the City that are a result of the actions or failure to act of the Contractor will be deducted from any payment that is due to the Contractor. If the fine, penalty or other monetary sanction is levied after Contractor receives payment, Contractor shall reimburse the City within 10 days of written notice for all such fines, penalties or monetary sanctions.

M. **Withholding.** Contractor must require that its employees comply with the City of Jackson rules for withholding of income tax for work performed in the City of Jackson. In addition, all contracts between the Contractor and any subcontractors must contain a provision requiring the subcontractor to comply with the City of Jackson rules for withholding of income tax for work performed in the City of Jackson. Copies of such contract language must be provided to the City prior to commencement of work by the subcontractor.

N. **Entire Agreement.** This Agreement constitutes the entire understanding of the parties and supersedes all prior and contemporaneous agreements, negotiations and representations of any kind, both written and oral, with respect to the subject matter of this Agreement. This Agreement supersedes any agreements submitted by the Contractor, and in the event of conflicting provisions, the provisions of this Agreement as drafted by the City shall control even if an agreement, specification or proposal submitted by the Contractor was executed contemporaneously with this Agreement and even if the agreement, specification or proposal submitted by the Contractor claims to supersede this Agreement.

BOND NO. \_\_\_\_\_

**PERFORMANCE BOND**

KNOW ALL MEN BY THESE PRESENTS, that we,  
\_\_\_\_\_  
Contractor, as Principal, and  
\_\_\_\_\_

as Surety, are held and firmly bound unto THE CITY OF JACKSON, MICHIGAN, 161 West Michigan Avenue, Jackson, Michigan 49201, Owner, in the sum of ( ) to be paid to the Owner for which payment well and truly be made we jointly and severally bind ourselves, our heirs, executors, administrators, and assigned firmly by these presents.

THE CONDITION OF THE ABOVE OBLIGATIONS ARE such that,

WHEREAS, the said \_\_\_\_\_ (CONTRACTOR) did, on the \_\_\_\_\_ day of \_\_\_\_\_, \_\_\_\_\_, enter into a certain contract with the said Owner for the \_\_\_\_\_ in accordance with drawings, specifications, conditions and stipulations prepared by \_\_\_\_\_,

which said contract, drawings, specifications, conditions and stipulations are by reference made a part hereof as if fully set out herein, and is hereinafter referred to as the Contract.

NOW, THEREFORE, the condition of the foregoing obligation is such that, if the said Contractor shall save harmless the said Owner from all public liability and damages of every description in connection with the Contract, shall well and faithfully in all things fulfill the Contract according to all the drawings, specifications, conditions and stipulations therein contained in all respects, and shall save and hold harmless the said Owner from and against all liens and claims of every description in connection with the Contract, then this obligation shall be void and of no effect; but otherwise, it shall remain in full force and virtue;

B-1

AND PROVIDED, that any alterations which may be made in the terms of said Contract, or in the work be done under it, or in the event that the said Owner shall grant any extension of time for the performance of said contract or otherwise modify any elements of the Contract, or any forbearance on the part of either party to the other shall not in any way release the Principal and Surety, or either of them, their heirs, executors, administrators, successors or assigns, from any liability hereunder, notice to the Surety of any such alterations, modifications, extension or forbearance being hereby waived.

WITNESS our hands and seals this \_\_\_\_\_ day of \_\_\_\_\_, \_\_\_\_\_.

WITNESS:

\_\_\_\_\_  
Principal  
\_\_\_\_\_  
By  
Title \_\_\_\_\_

WITNESS:

\_\_\_\_\_  
Surety  
\_\_\_\_\_  
By  
Attorney-in-fact

ATTACH POWER OF ATTORNEY

B-2

BOND NO. \_\_\_\_\_

**LABOR AND MATERIAL PAYMENT BOND**

KNOW ALL MEN BY THESE PRESENTS, that we, \_\_\_\_\_, Contractor, hereinafter called Principal, and \_\_\_\_\_ hereinafter called the Surety, are held and firmly bound unto THE CITY OF JACKSON, MICHIGAN, 161 West Michigan Avenue, Jackson, Michigan 49201, hereinafter called the Owner, and the State of Michigan in the sum of \_\_\_\_\_ to the payment whereof, well and truly to be made, we bind ourselves, our heirs, executors, administrators, successors, and assigns, jointly and severally, firmly by these presents.

Sealed with our seals and dated this \_\_\_\_\_ day of \_\_\_\_\_, \_\_\_\_\_.

WHEREAS, the above named Principal has entered into a certain contract with THE CITY OF JACKSON, MICHIGAN, 161 West Michigan Avenue, Jackson, Michigan 49201, Owner, dated the \_\_\_\_\_ day of \_\_\_\_\_, \_\_\_\_\_ for \_\_\_\_\_ which contract and the specifications for said work shall be deemed a part hereof as fully as if set out herein and is hereinafter referred to as the Contract.

AND WHEREAS, this bond is given in compliance with and subject to the provisions and conditions of Public Act No. 213 of the Public Acts of Michigan of 1963, as amended.

NOW, THEREFORE, THE CONDITION OF THIS OBLIGATION IS SUCH that if the above named Principal, legal representatives, or successors shall pay or cause to be paid to all subcontractors, persons, firms and corporations as the same may become due and payable, all indebtedness which may arise from said Principal to a subcontractor or any party performing labor or materials furnished in connection with the Contract, construction, and work herein referred to, then this obligation shall be void; otherwise to remain in full force and effect.

B-3

AND PROVIDED, that any changes, alterations, or modifications which may be made in the terms of said Contract, or in the work to be done under it, or in the event that the said Owner shall grant any extension of time for the performance of said contract or otherwise modify any elements of the Contract, or any forbearance on the part of either party to the other shall not in any way release in Principal and Surety, or either of them, their heirs, executors, administrators, successors or assigns, from any liability hereunder, notice to the Surety of any such changes, alterations, modifications, extensions or forbearance being hereby waived.

IN WITNESS THEREOF, the parties hereto have caused this instrument to be executed by their respective authorized officers this \_\_\_\_\_ day of \_\_\_\_\_, \_\_\_\_\_.

WITNESS:

\_\_\_\_\_  
Principal  
\_\_\_\_\_  
By  
\_\_\_\_\_  
Title

WITNESS:

\_\_\_\_\_  
Surety  
\_\_\_\_\_  
By  
\_\_\_\_\_  
Attorney-in-fact

ATTACH POWER OF ATTORNEY

B-4

BOND NO.

**MAINTENANCE AND GUARANTEE BOND**

KNOW ALL MEN BY THESE PRESENTS, that \_\_\_\_\_, Contractor, as Principal, and \_\_\_\_\_, as Surety, are held and firmly bound unto THE CITY OF JACKSON, MICHIGAN, 161 West Michigan Avenue, Jackson, Michigan 49201, Owner, in the sum \_\_\_\_\_ Dollars (\$\_\_\_\_\_) to be paid to said Owner, its legal representatives and assigns, for which payment well and truly be made, we bind ourselves, our heirs, executors, administrators, successors and assigns, and each and every one of them jointly, firmly by these presents.

Sealed with our seals and dated this \_\_\_\_\_ day of \_\_\_\_\_, 20\_\_\_\_\_.

WHEREAS, the above named Principal has entered into a certain contract with THE CITY OF JACKSON, MICHIGAN, 161 West Michigan Avenue, Jackson, Michigan 49201, Owner, dated the \_\_\_\_\_ day of \_\_\_\_\_, 20\_\_\_\_\_, wherein the said Principal covenanted and agreed as follows, to-wit: \_\_\_\_\_

\_\_\_\_\_  
and

WHEREAS, said contract was awarded upon the express condition that the said Principal would furnish a \_\_\_\_\_ (\_\_\_\_\_) year (s) Maintenance and Guarantee Bond.

NOW, THEREFORE, THE CONDITION OF THIS OBLIGATION IS SUCH that by and under

said Contract, the above named Principal has agreed with the said Owner that for a period of \_\_\_\_\_ (\_\_\_\_\_) years(s) from the date of final payment, to keep in good order and repair any defect in all the work done under said contract either by the Principal or his subcontractors, or his material suppliers, that may develop during said period due to improper materials, defective equipment, workmanship or arrangements, and any other work affected in making good such imperfections, shall also be made good all without the consent or approval of the Principal after the final acceptance of the work, and that whenever directed to do so by the Owner, by notice served in writing, either personally or by mail, on the Principal at the address appearing in the contract documents or upon said Principal's legal representatives, or successors, or on the Surety at the address appearing below,

WILL PROCEED at once to make sure repairs as directed by said Owner; and in case of failure to do so within one week from the date of service of such notice, or within reasonable time not less than one week, as shall be fixed in said notice, then the said Owner shall have the right to purchase such materials and employ such labor and equipment as may be necessary for the purpose, and to undertake, do and make such repairs, and charge the expense thereof to, and receive same from said Principal or Surety. If any repair is necessary to be made at once to protect life and property, then and in that case, the said Owner may take immediate steps to repair or barricade such defects without notice to the Principal or Surety. In such accounting the said Owner shall not be held to obtain the lowest figures for the doing of the work, or any part thereof, but all sums actually paid therefore shall be charged to the Principal or Surety. In this connection the judgement of said Owner is final and conclusive. If the said Principal for a period of \_\_\_\_\_ (\_\_\_\_\_) year(s) from date of final payment shall keep said work so constructed under said contract in good order and repair, excepting only such part or parts of said work which may have been disturbed without the consent or approval of said Principal after the final acceptance of the same, and shall whenever notice is given as hereinbefore specified, at once proceed to make repair as in said notice directed, or shall reimburse said Owner for any expense incurred by making such repairs, should the Principal or Surety fail to do so as hereinbefore specified, and shall fully indemnify, defend and save harmless the said Owner from all suits and actions for damages of every name and description brought or claimed against it for on account of any injury or damage to person or property received or sustained by any party or parties, by or from any of the acts or omissions or through negligence of said Principal, servants, agents, or employees in the prosecution of the work included in said contract, and from any and all claims arising under the Workers' Compensation act, so-called, of the State of Michigan, then the above obligation shall be void, otherwise to remain in full force and effect.

IN WITNESS THEREOF, the parties hereto have caused this instrument to be executed by their respective authorized officers, this \_\_\_\_\_ day of \_\_\_\_\_, 20 \_\_\_\_\_.

WITNESS:

\_\_\_\_\_  
Principal  
\_\_\_\_\_  
By  
\_\_\_\_\_  
Title  
\_\_\_\_\_

WITNESS:

\_\_\_\_\_  
Surety  
\_\_\_\_\_  
By  
\_\_\_\_\_  
Attorney-in-fact

## ATTACH POWER OF ATTORNEY

B-7

## Section 08 71 13 ADA Operators

### Part 1 General

#### 1.1 Section Includes

A. Aluminum doors and frames.

B. Work included: Furnish all labor, materials, equipment and services necessary for the proper installation of the record-usa 8100 swinging door system, a Low Power Operated Door System as defined in ANSI/BHMA A156.19-2002, and have an AAADM certified inspector on staff.

#### 1.2 Related Sections

C. Section \_\_\_\_\_ – \_\_\_\_\_: Aluminum doors and frame

D. Section 08211 – Flush Wood Doors.

E. Division 16- Electrical wiring shall be as described in electrical section of the specifications. The Electrical Contractor shall provide 115V, 60 HZ, 1-phase, 15 amp dedicated circuit to the door header. Two conductor 18 AWG N.E.C. Class II low voltage wire cable shall be provided by the Electrical Contractor between the door header and all activation devices (buttons, switches, push plates).

F. Electrical wiring and connections by Electrical Contractor. Buttons and push plates at door locations provided by Door Operator Installer.

G. The general contractor shall provide adequate support for the door operating equipment.

H. The installer of the equipment shall inspect the condition of the support and shall notify the contractor if additional support is required. By installing his equipment, the installer accepts the support as adequate to properly support the equipment.

#### 1.3 References

B. ANSI/BHMA A156.19-2002 American National Standard for Power Assist & Low-Energy Power Operated Doors.

C. UL 325 – Standard for Door, Drapery, Gate, Louver and Window Operators and Systems.

#### 1.4 Submittals

A. Submit under provisions of Section 01300.

B. Product data: Within 15 calendar days after the contractor has received the owner's notice to proceed, submit:

1. Shop drawings showing exact dimension for each door unit including operator details, electric strike interface (if required) and wiring details. Also, show a plan indicating exact location of all activating devices.

2. Manufacturer's specifications and other data needed to prove compliance with the specified requirements. Provide cut and data sheets on all parts being used.

#### 1.5 Quality Assurance

- A. The door operator shall be manufactured by an ISO 9001 registered company with a minimum of 5 years experience in producing electro-mechanical door systems.
- B. Door operators and accessories shall be installed by a factory-trained contractor with a minimum experience of 3 years and in strict accordance with the manufacturer's recommendations. The installed equipment shall be subject to inspection and final acceptance by the Architect.

#### 1.6 Product Handling

- A. Comply with pertinent provision of Section 01640.

#### 1.7 Warranty

- A. The record-usa 8000 equipment and controls shall be warranted for two (2) years from the date of manufacture. Warranty paper(s) shall be given to the owner upon completion of the job.

### Part 2 Products

#### 2.1 Manufacturers

- A. Acceptable manufacturer: Series 8100 Electromechanical Automatic Swing Door Operator as detailed shall be supplied by record-usa, Monroe, N.C. All equipment must meet the requirements of the American National Standard for High Energy Power Operated Doors, ANSI/BHMA A156.10-2005 and be adjustable to meet ANSI/BHMA A156.19-2002 Standard for Low Energy Power Operated Doors.
- C. Provide all door operators from a single manufacturer.

## 2.2 Doors and Frames

### A. Doors and Frames: Extruded aluminum.

1. Finish: Bronze Anodized aluminum for door system #3, Clear Anodized aluminum for door systems #1 & #2. Submit samples for review and approval.

### B. Doors and Frames: Specified elsewhere; see drawing for configuration.

1. Operator: Overhead, surface-mounted.

2. Actuator: Push plate. Jamb mounted or wall mounted (2) recommended per opening

## 2.3 Operator Components

### A. Door Operators - Operation: Electric power open with spring and power boost closing and holding; comply with ANSI A156.19-2002 and UL 325.

1. The operator must be designed to handle swing doors up to a weight of 350 lbs. (113kg).

2. Close and center door against stop after each cycle, and hold against drafts, winds and stack pressure.

4. Manual opening force: not to exceed 15 lbs. (67 N)

5. The force required to prevent a stopped power operated swinging door from moving in the direction of closing shall not exceed a 30 lbf (133 N) measured 1 in. from the lock edge of the door at any point in the closing cycle.

6. Manual switch between spring close-and-hold and power boost-close-and-hold.

7. Power boost-close-and-hold: Electronically increase door closing force not to exceed 30lbs.

8. Provide adjustments by self-contained microprocessor control as listed below:

a. The microprocessor control shall be easily field adjustable to comply with ANSI A156.10-2005 Standard for Full energy Automatic Door Systems or A156.19-2002 Standard for Low energy Automatic Door Systems.

#### Code requirements:

1) Field adjustments for door opening speed, door opening force, door closing speed, and door closing force shall be standard within the unit and adjust independently from all other external requirements. The same unit will be able to be converted easily in the field from full energy to low energy without the necessitation of a new unit being provided.

b. Opening time to 80 degrees shall not be less than 1 ½ seconds as required in ANSI

A.156.10-2005.

- c. The force to prevent a stopped door from opening in the last 10 degrees of opening, or at any point in closing shall not exceed 40 lbs. (180 N).
  - d. Backcheck speed.
  - e. Hold-open: The door shall be field adjusted to remain fully open for not less than 5 seconds.
  - f. Door closing shall be by spring force and monitored by the microprocessor control, capable of providing limited power assist to insure the door closes.
  - g. Closing speed: Doors shall be field adjusted to close from 90 degrees to 10 degrees in 2 seconds or longer as required in Table 10.2.5 of ANSI A156.10-2005, dependent upon final door weight.
  - h. Doors shall close from 10 degrees to fully closed in not less than 1.5 seconds.
  - i. Door will safely stop and reverse if an object is encountered in the opening cycle (Obstruction Shut Down).
  - j. Delayed activation to provide 1 second delay between reception of the activation signal and actual opening of the door.
  - k. Logic terminal for interface with accessories and sensors.
9. Factory-set door hold-open voltage.
10. Manual "Off/Auto/Hold-Open" rocker or key switch.
11. Fail safe: In event of power failure, make door operate manually with controlled spring close as though equipped with a #3 manual door closer without damage to operator components.

#### B. Display Board

1. Unit will provide the ability to determine diagnostic evaluation of problematic issues through a digitized display panel. When provided, the display will provide confirmation that the door is performing properly and also provide error codes when it is not. This same panel shall also provide systematic information such as counters for usage determination, and provide the installing contractor's telephone number in the event of service requirements.

#### C. Door Operators - Construction: The door operating equipment must use the electro-Mechanical 8100 series drive system.

- 1. Unit must be non-handed, and able to operate as an in-swing or out swing unit with simple Field modifications.
- 2. The unit must be factory assembled, adjusted and tested.
- 3. Gear box operator: Self-contained cast aluminum housing, with precision-machined gears and bearing seals and all-weather lubricant, and not require vibration isolators. No exposed gears. The gear box shall use an adjustable compression spring engineered for maximum life. No electro hydraulic equipment shall be allowed.

4. Motor: DC permanent magnet motor with shielded ball bearings. Motor will stop when the door stops or is fully open and when breakaway is operated.
  5. Door operating arm: Forged steel, and aluminum and shall be either linkage or a track type arm.
    - a. Exposed arms: Factory-painted and finished to match operator enclosure.
    - b. Overhead concealed butt hung, provide concealing arm channel.
  6. Microprocessor control: 115 VAC. Do not use microswitches.
  7. "Off/Auto/Hold-Open" three-position rocker or key switch.
  8. Control circuits for actuators and safeties: Low-voltage, NEC Class II.
  9. Service conditions: Satisfactory operation between –40 degrees F (-40 degrees C) and 140 degrees F (60 degrees C).
  10. Power supply required: 115 VAC (15 amp circuit breaker one per unit).
- D. Operator Enclosure: Extruded header concealing all operating parts except arms and manual control switches.
1. Surface Mounting: On surface of door frame/wall, mounting 1" (25.4 mm) above top of door.
  2. Design for Interior and exterior application.
  3. Header Size: 4-1/2" (114 mm) high x 5" (127 mm) deep, by the width of the door panel(s) plus 3" (76mm).
  - 4.
  5. Finish of Exposed Headers: Dark Bronze Anodized for Door #3, Clear Anodized for Door #1 & #2 DB313R1

## 2.4 Actuators (For Low Energy Operators)

- A. Jamb-Mounted Push Button Switch 619H: No. 9730100; two recommended per opening.
- B. Wall-Mounted Push Button Switch 59H: No. 9730087; two recommended per opening
1. Material: Stainless steel.
  6. Marking: "Push to Open."

D. Wireless Remote Switch: \_\_\_\_\_.

E. Motion Detector: \_\_\_\_\_.

F. Key Switch: \_\_\_\_\_.

G. Card Reader: By others.

H. Doors shall be equipped with a sign(s) visible from either side, instructing the user as to the operation and function of the door. Signs or stickers should include the following:

1. PUSH TO OPERATE
2. PULL TO OPERATE
3. AUTOMATIC PUSH SWITCH TO OPEN
4. CAUTION – AUTOMATIC DOOR

## Part 4 Execution

### 4.1 Surface Conditions

A. Examine the areas and conditions under which work of this section will be performed. correct conditions detrimental to timely and proper completion of the work. Do not proceed until existing unsatisfactory conditions are corrected.

### 4.1 Examination

- A. Verify that door openings and doors are properly installed and ready for installation of automatic door equipment.
- B. Verify that electrical service is available, properly located and of proper type.

### 4.2 Installation

- A. Install in accordance with manufacturer's instructions; comply with ANSI A156.19-2002.
- B. The general contractor shall provide adequate support for the door operating equipment so that equipment is secure and located in the proper position.
- C. Coordinate as required with the other trades to assure proper and adequate provision in the work of those trades for interface with the work of this section.
- D. Verify that electrical connections are made correctly and with dedicated grounding.

### 4.3 Adjust and Clean

- A. Adjust doors and operators for proper operation, without binding or scraping and without excessive noise.
- B. Clean Glass.
- C. Supply Owner/Contractor with AAADM Certified Daily Safety Check.
- D. Supply Owner/Contractor with keys if required.
- E. Supply Owners Manual.

End of Section

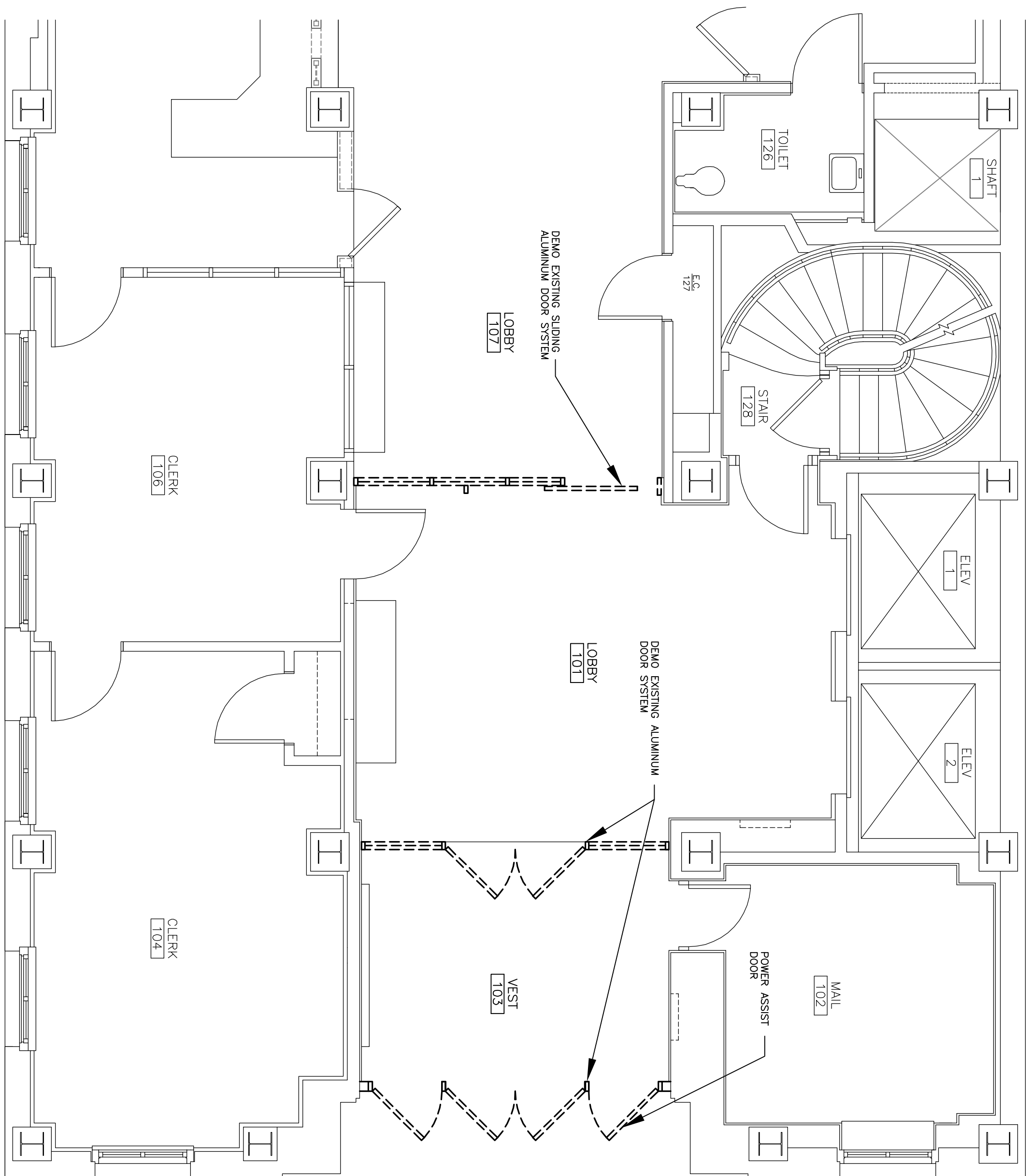

DEMOLITION PLAN  
1/4" = 1'-0"

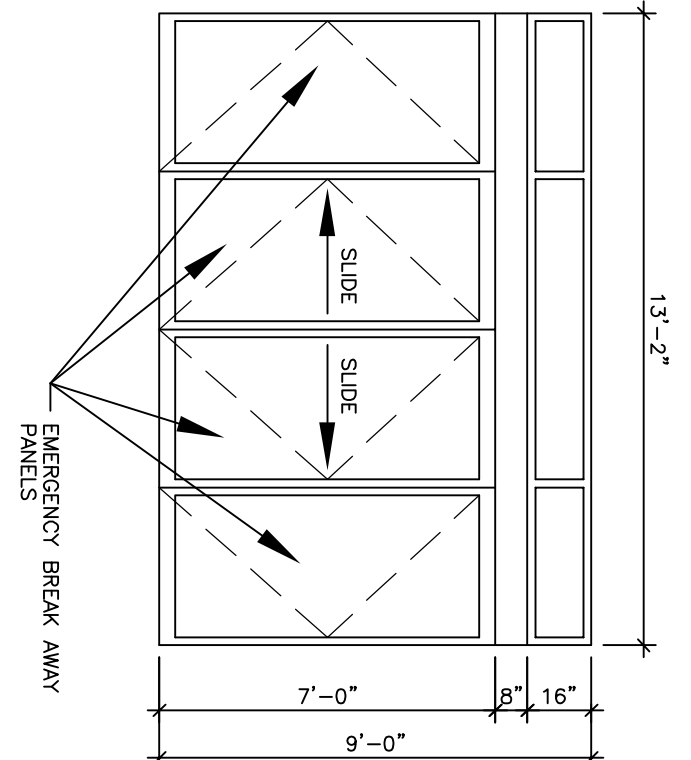

**DOORS #1 AND #2**  
SLIDING DOOR SYSTEM TO BE RECORD-USA SERIES 5100 WITH BEA MODEL #110-011 ACTIVATION AND SAFETY SENSOR WITH 1/4" INSULATED CLEAR GLASS OR EQUAL. GLAZING SHALL BE 1/4" TEMPERED CLEAR GLASS

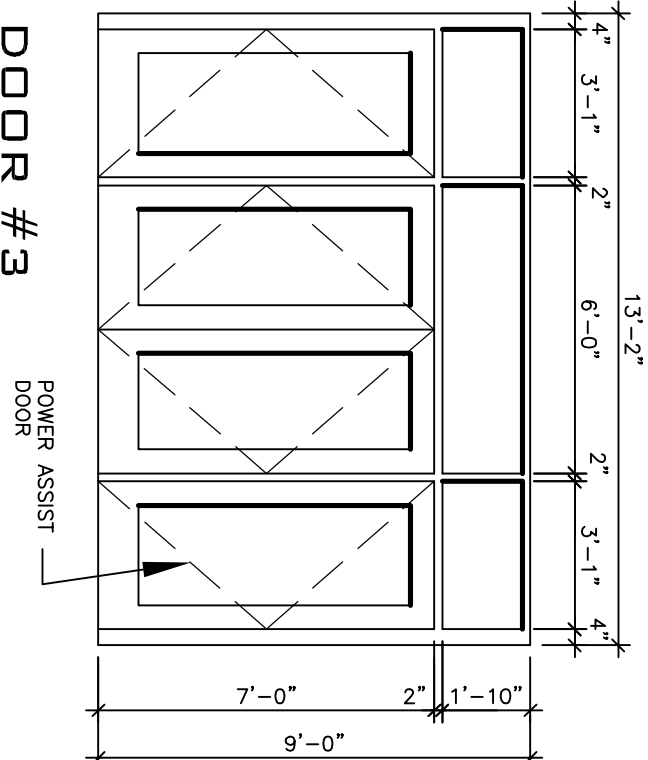

**DOOR #3**  
ALUMINUM STOREFRONT SYSTEM TO BE KAWNEER TRIP V6 4511 WITH 1/4" INSULATED CLEAR GLASS PROVIDE SAFETY GLAZING AS REQUIRED PER IBC 2015 SECTION 2406.

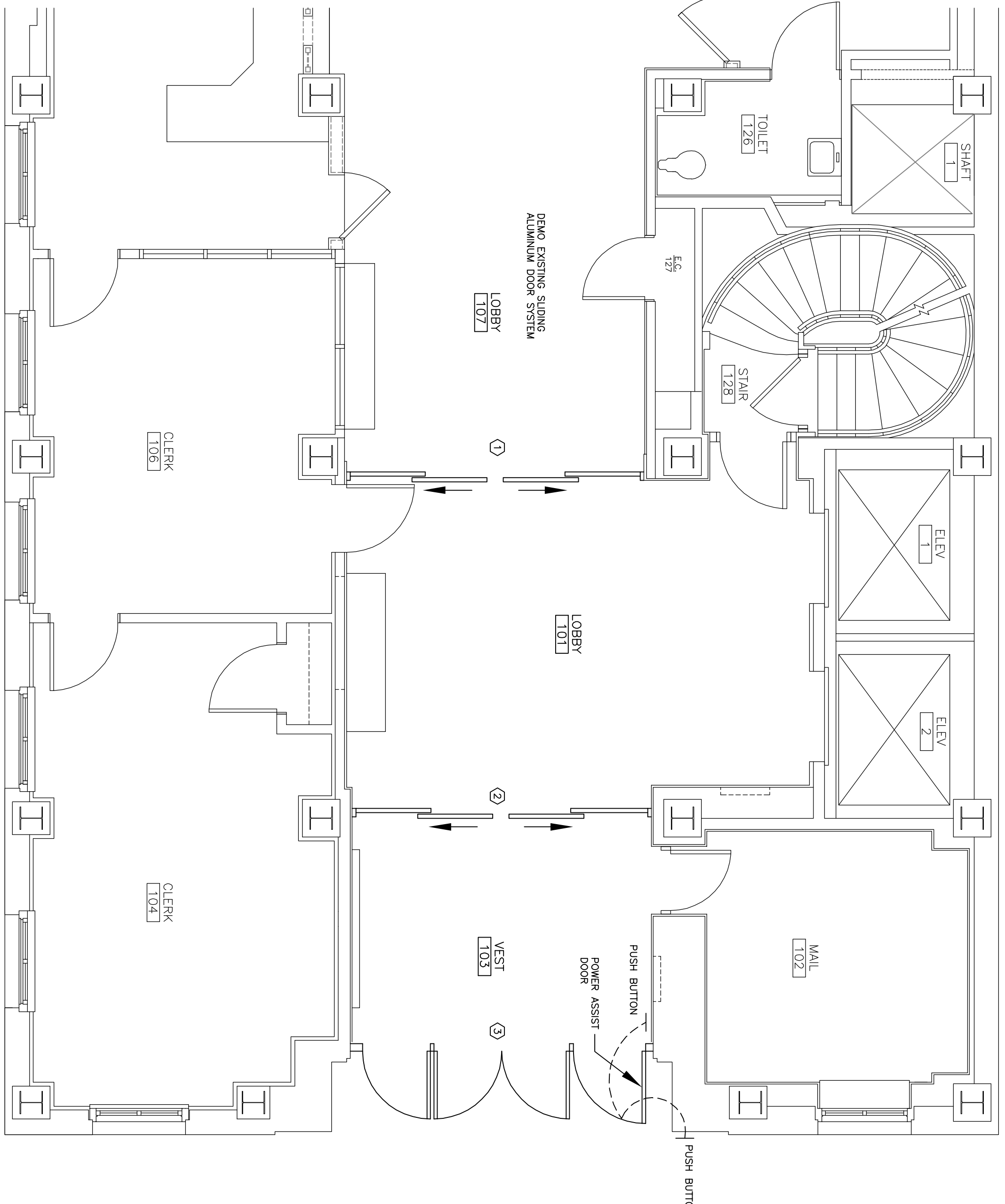

FLOOR PLAN  
1/4" = 1'-0"

- NOTES:
1. RE-USE EXISTING POWER AT DEMO DOOR LOCATIONS FOR CIRCUIT FOR POWER OPERATOR (SEE NOTES) SECTION
  2. PATCH AND PAINT ADJACENT WALL AND CEILING SURFACES AT ALL WORK AREAS. CAULK ALL AT ALL NEW FRAMING EDGES TO ADJACENT SURFACE
  3. PROVIDE ORIGINAL MATERIALS
  4. FIELD MEASURE ALL NEW DOOR OPENINGS
  5. PROVIDE SHOP DRAWINGS FOR OWNER REVIEW PRIOR TO ORDERING MATERIALS AND FABRICATION

ALL REPORTS, PLANS, SPECIFICATIONS, COMPUTER FILES, FIELD DATA, NOTES AND OTHER DOCUMENTS AND INSTRUMENTS PREPARED BY THE DESIGN PROFESSIONAL AS INSTRUMENTS OF SERVICE SHALL REMAIN THE PROPERTY OF THE DESIGN PROFESSIONAL. THE DESIGN PROFESSIONAL SHALL RETAIN ALL COMMON LAW, STATUTORY AND OTHER RESERVED RIGHTS, INCLUDING THE COPYRIGHT THEREON.

SHEET NUMBER  
**A1**

SHEET TITLE  
**DEMOLITION AND NEW FLOOR PLANS**

FILE NUMBER  
2219

DRAWN BY  
J.C.

DATE ISSUED

DATE	REVISIONS	APP'D
5-4-18	ISSUED FOR BIDDING	J.C.

PROJECT  
**JACKSON CITY HALL LOBBY DOOR REPLACEMENT**

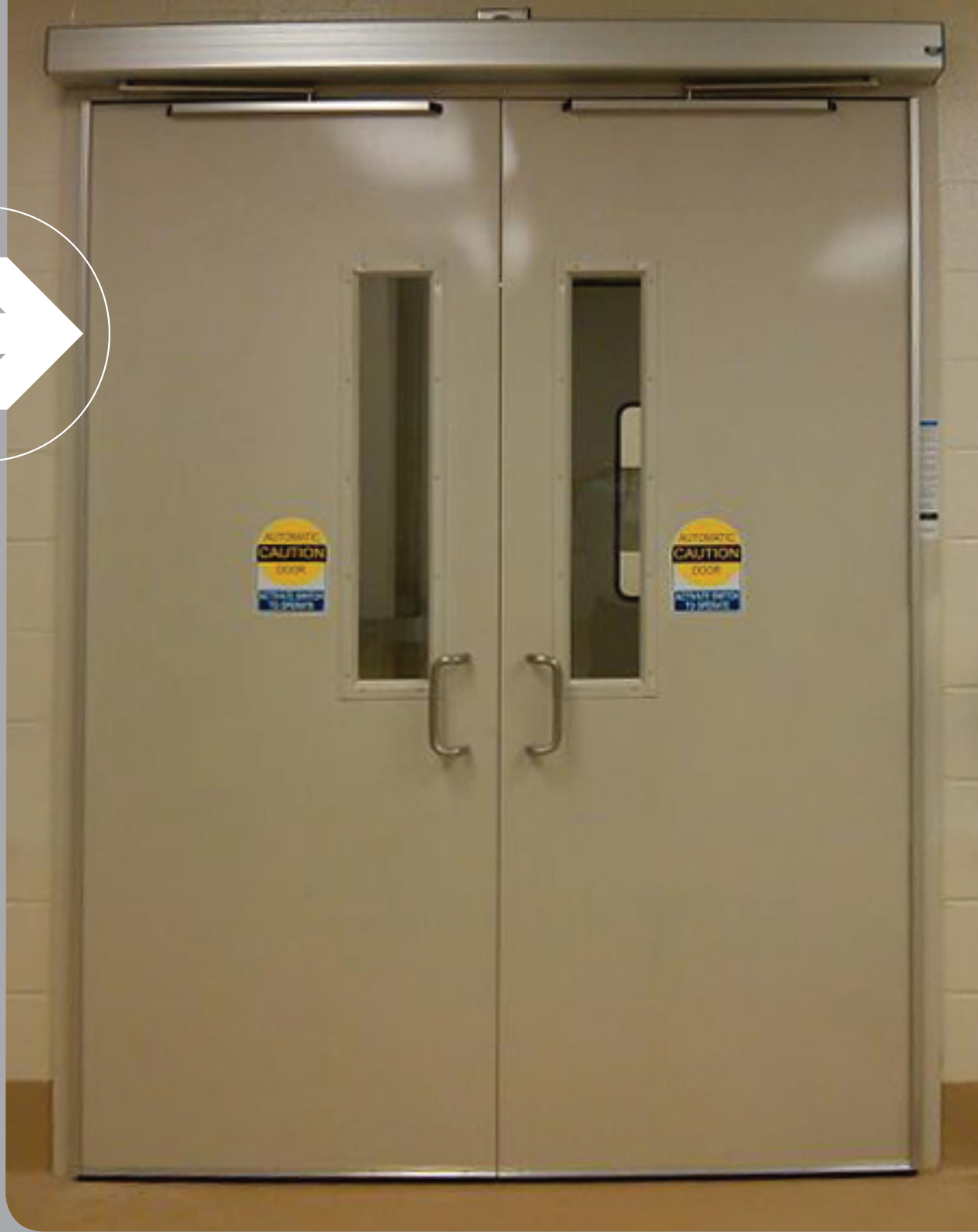
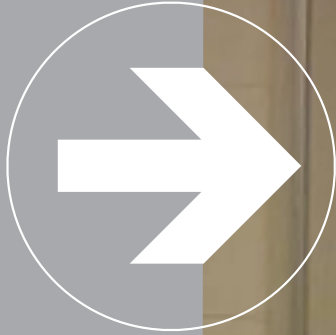

# 8100 Series Swing Door Heavy Duty Operator

Automatic door technology as you've never seen it before!



**record**

your global partner for entrance solutions

## 8100 Series

A proven planetary gear system in tandem with a perfected lever-system arm assures the smoothest, most quiet operation available without exception. Libraries, doctor offices, and healthcare facilities demand that their daily routines proceed without the common noisy distractions associated with many competitive products. Eliminate your worry of post install performance by specifying record-usa's 8100 series without hesitation.

Combined with World famed Swiss precision technology and a patented control system with 32 bit processor technology, the 8100 series is powerful and intelligent. The 8100 guarantees rapid and reliable door control performance, even when complex functions are desired.

When programming the 8100 series with record-usa's available hand held remote you will be greatly impressed with the quick and easy diagnostics and software updates that make field adjustment easy to configure and program. Using state of the art computer chip technology incorporating flash memory, the installing contractor can program multiple entranceways to open and close at the exact same speed with each and every opening.



record-usa's 8100 series swinging door operator makes everyone's decision making process simpler in that it truly can be selected for most any application. An ingenious design platform allows each unit to be used on virtually any door configuration including:

- Right hand or left hand doors
- Inswinging or outswinging doors
- Single, pairs or double egress doors
- Balanced doors
- Swing clear doors
- Interior doors
- Surface applied
- Center hung doors
- Butt hung doors
- Deep reveal applications
- Libraries, elderly care facilities, universities, hospitality, storefronts
- Front entrances in retail applications
- Meets ANSI A 156.19 requirements when adjusted properly
- Meets ANSI A 156.10 requirements when adjusted properly
- Exterior doors
- Fire rated openings
- Available clear or dark bronze anodized, custom painted, and clad
- ADA applications
- Electric strikes without additional relays or delays
- Up to 350 pounds per door leaf
- 30" doors through 96" door openings
- Push to start applications eliminate the need for additional activation accessories and complex field wiring
- Latch assist function assures closing in areas with heavy stack conditions commonly associated with doors in air conditioned and heated environments
- Specify 8200 Series when a squared header is desired.

## Brake Feature

An optional feature for the 8000 series Swing Door Operator systems is an internal clutch/ brake to maintain door position at the full-open and/ or full closed position(s). This electro-mechanical unit is integrated within the encoder assembly and will hold door position with 90 ft-lbs. torque. If forces are applied to the door which exceeds this force, the clutch feature of the unit will allow rotation without physical damage to the operator.

## Arm Options



The Standard Arm Assembly, 9-80-0010-CL, will work in out swing (push) applications up to a 12" reveal, and in swing (pull) applications up to a 6" reveal.

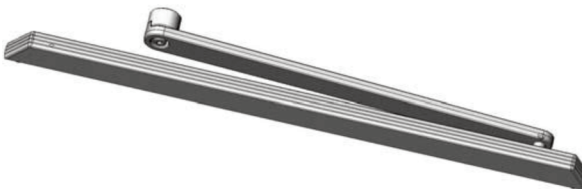

The Slide Track Arm Assembly, 9-80-0012-CL, will work in out swing (push) applications up to a 3" reveal, and in swing (pull) applications up to a 6" reveal.



The Offset Arm Adapter, 9-80-0011-CL, can be used with the above Slide Track Arm Assembly to provide a solution for special applications, such as center-pivoted doors with breakout capability, or double-egress installations using a continuous header.

Extended Reveal Applications will require an extension of the secondary (adjustable) arm portion of the Standard Arm Assembly. This is accomplished by combining two secondary arm assemblies. Reveals of up to 24" are possible.

# 8100 Series





**record-usa**  
4910 STARCREST DR.  
MONROE, NC 28110  
(704) 289 - 9212

JOB NAME: \_\_\_\_\_

LOCATION: \_\_\_\_\_

**AUTOMATIC SWING DOOR OPERATORS**

SERIES: 8100 LOW/HIGH ENERGY OPERATOR  
MODEL: 8100 (RHR) 8101 (LHR),  
TYPE: OUTSWING (STANDARD ARM) PAGE 81-2.01

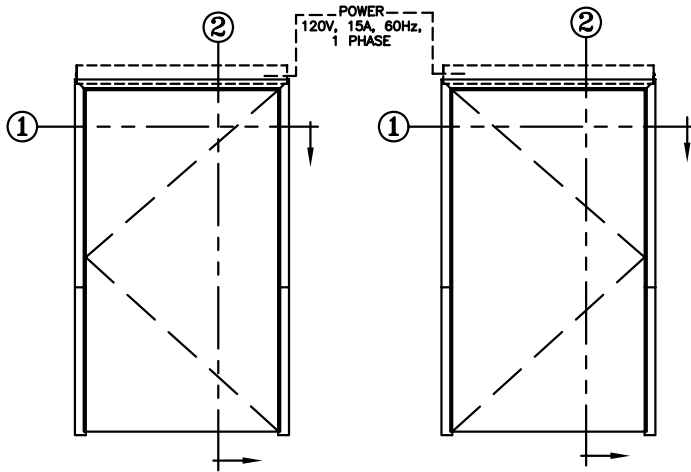

**ELEVATION VIEW**

SCALE: 1/4" = 1'0"

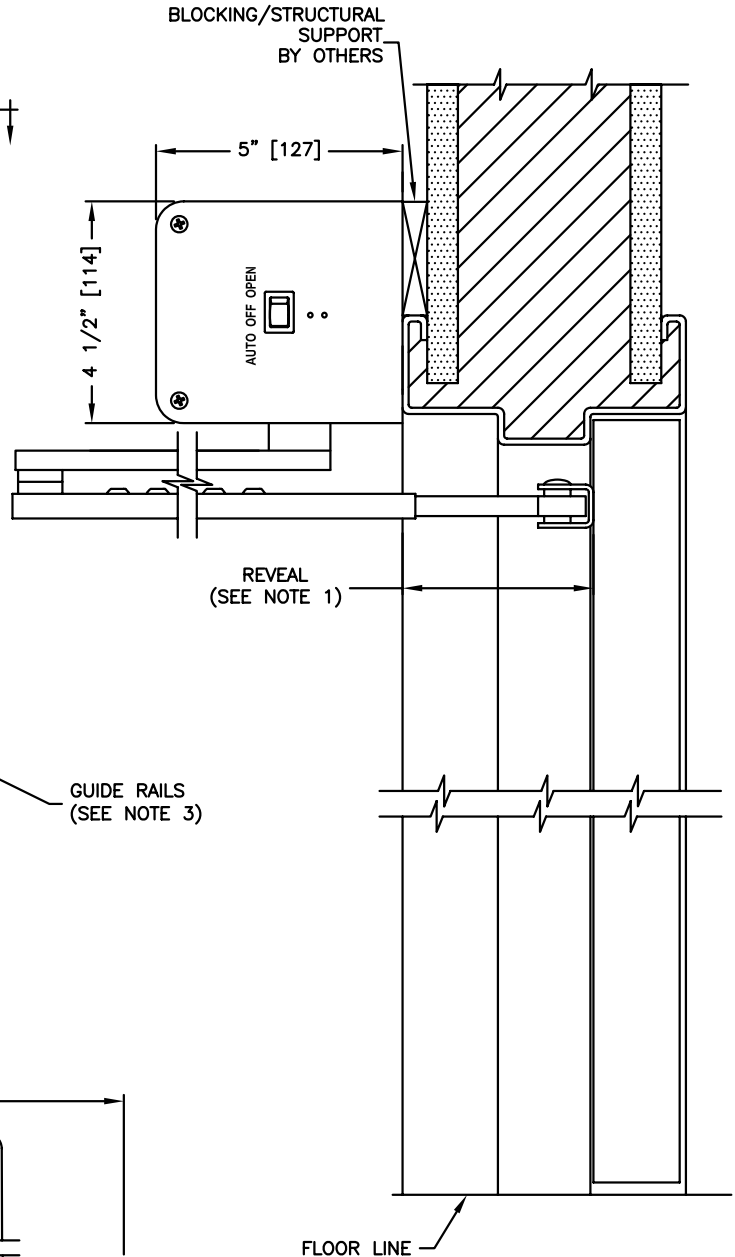

**SECTION: 2**

SCALE: 1/4 SIZE

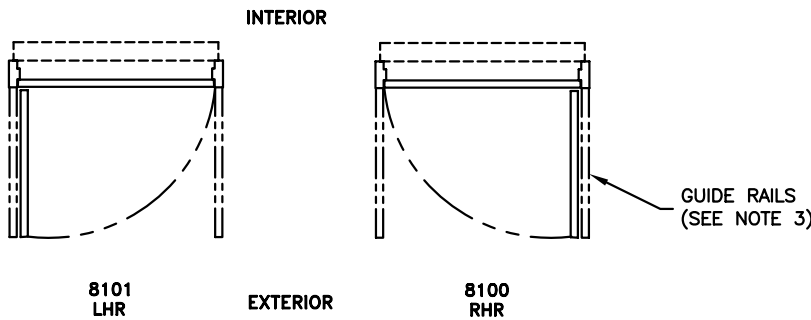

**PLAN VIEW**

SCALE: 1/4" = 1'0"

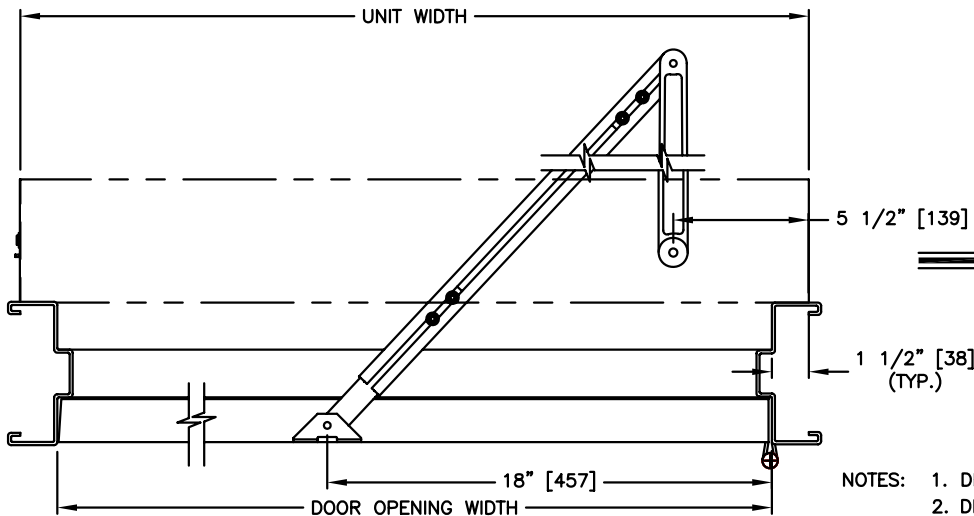

**SECTION: 1**

SCALE: 1/8 SIZE

RHR SHOWN  
(LHR OPPOSITE)

- NOTES:
1. DEPTH OF REVEAL UP TO 12" [305]
  2. DIMENSIONS IN INCHES [MILLIMETERS].
  3. SELECTION OF OPERATOR FROM 8100 (LOW ENERGY) TO 8000 (HIGH ENERGY) WILL DETERMINE THE NEED FOR GUIDE RAILS AND SAFETY SYSTEMS AND IS THE RESPONSIBILITY OF THE INSTALLER